

www.pfcstore.com - 763-425-7890 / 800-328-2350



## FILTRAFINE MSB BAG HOUSING IN 316SS & ASME CERTIFIED

**Contact us for pricing.** Number 2 / 6 Bags | 316SS, EPDM Gasket | Bottom in - Bottom out | 6" ANSI FLANGE | Legs Included | Max Flow 1055 GPM | Max PSI 150 |



---

**SKU:** 6MSB2-316-6FDA-C150-U  
**Stock:** Out of stock contact us for lead time

**Categories:** [Filtrafine Housings](#)

**Model Number** 6MSB2-316-6FDA-C150-U

**Part Number** 31032200044

## GALLERY IMAGES

www.pfcstore.com - 763-425-7890 / 800-328-2350

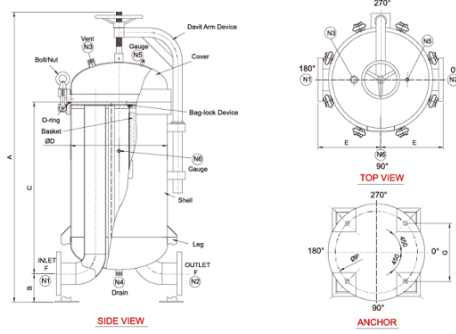

www.pfcstore.com - 763-425-7890 / 800-328-2350

## PRODUCT DESCRIPTION

Filtrafine MSB Bag Housings

**Estimated delivery is 1 to 2 weeks**

[MSB Specs](#)

## ADDITIONAL INFORMATION

<b>Weight</b>	950 lbs
<b>Dimensions</b>	20 × 20 × 70 in
<b>Connections</b>	<u><a href="#">6" ANSI FLANGE</a></u>
<b>Max GPM</b>	<u><a href="#">1055</a></u>
<b>Max PSI</b>	<u><a href="#">150</a></u>
<b>Vessel</b>	<u><a href="#">SIX-#2 BAG</a></u>
<b>Wetted Material</b>	<u><a href="#">316SS-EPDM</a></u>

**Contact us for pricing.** Number 2 / 6 Bags | 316SS, EPDM Gasket | Bottom in - Bottom out | 6" ANSI FLANGE | Legs Included | Max Flow 1055 GPM | Max PSI 150 |