

www.pfcstore.com - 763-425-7890 / 800-328-2350



WALCHEM COOLING TOWER CONTROLLER, THE WCTW100P

3 Powered Relays | Prewired with Pigtails | One Sensor Card | No Analog Outputs | No Ethernet | On Panel - Graphite contacting conductivity + Flow Switch manifold on panel, prewired



SKU: WCTW100PNB

Stock: Out of stock contact us for lead time

Categories: [Walchem Controllers](#)

Model Number WCTW100PN-B

GALLERY IMAGES

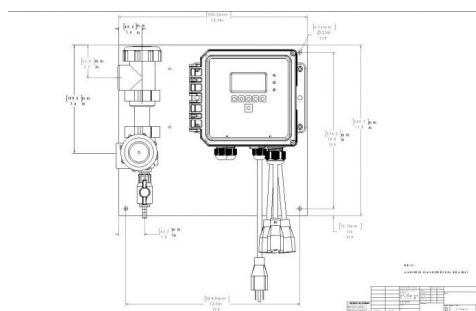

www.pfcestore.com - 763-425-7890 / 800-328-2350

www.pfcstore.com - 763-425-7890 / 800-328-2350

PRODUCT DESCRIPTION

Walchem Cooling Tower Controller

Estimated delivery 1 to 4 days

Contact us for actual lead time

Product photo could vary from the actual product

[W100 Brochure](#)

[W100 Manual](#)

[Build Your Own Controller](#)

ADDITIONAL INFORMATION

Weight	15 lbs
Dimensions	18 × 29 × 10 in
Controller Type	<u>WCTW100 Cooling Tower</u>
Relays / Wiring	<u>3 Powered Relays Prewired with Pigtails</u>

3 Powered Relays | Prewired with Pigtails | One Sensor Card | No Analog Outputs | No Ethernet | On Panel - Graphite contacting conductivity + Flow Switch manifold on panel, prewired