

03SH08B75T3F2

Technical Data

Company
Contact
Tel.
E-mail

Operating Data

1	Pump type	Single head pump	Fluid	Water
2	No. of pumps	1	Operating temperature t A	°F 39.2
3	Nominal flow	US g.p.m. 0	pH-value at t A	7
4	Nominal head	ft 0	Density at t A	lb/ft ³ 62.4
5	Static head	ft 0	Kin. viscosity at t A	ft ² /s 1.689E-5
6	Inlet pressure	psi 0	Vapor pressure at t A	psi 14.5
7	Environmental temperature	°F 68	Content of solid%	Solid size inch 0 0
8	Available system NPSH	ft 0	Altitude	ft 0

Pump Data

9	Design	Highly efficient stainless steel end suction pumps		
10	Execution	Rotation: 12 oClock [STD]		
11	Operating speed	rpm 3500	Impeller Ø	Max. inch 9 1/16
12	Group	M		Designed inch 8 11/16
13	Suction	NPS 4 / CL150 / ASME B16.5 (e-SH)		Min. inch 5 1/2
14	Discharge port	NPS 3 / CL150 / ASME B16.5 (e-SH)	Flow	Nominal US g.p.m.
15	Max. casing pressure	psi		Max- US g.p.m. 1075
16	Max. working pressure	psi 134.6		Min- US g.p.m. 200
17	Impeller type	Radial impeller	Head	Nominal ft
18	Head H(Q=0)	ft 310		at Qmax ft 207.4
19	Max. shaft power	hp 69.2	Shaft power	at Qmin ft 309.3
20	Pump weight	lb 136.0	Efficiency	hp
21	Total weight	lb On demand	NPSH 3%	%

Materials

Pump		Shaft Seal	
23	Casing	Stainless steel 316L	John Crane Elastomer Bellows Shaft Seal
24	Impeller	Stainless steel CF8M	Type 21
25	Wear Ring	Stainless steel 316L	Seal faces Carbon [STD]
26	Adapter	Gray cast iron class 20B	Stationary ring Silicon Carbide
27	Ball bearing (outboard)	Steel	Elastomers FKM
28	Pump shaft	Steel grade 1213	Springs Stainless steel CF8M (316)
29	Deflector	Buna-N	Other metal parts Stainless steel CF8M (316)
30	Shaft sleeve	Stainless steel CF8M (316)	
31	Bearing Cover	Gray cast iron class 20B	
32	Ball bearing (inboard)	Steel	
33	Impeller Key	Steel	
34	Seal Housing	Stainless steel 316L	
35	Impeller Washer	Stainless steel CF8M	
36	Bearing Frame	Gray cast iron class 20B	
37	Lip Seal	Steel/Buna-N	
38	V-Ring	Not available	
39	Casing bolt with nut (casing to adapter)	Stainless Steel	
40	Retaining ring	Steel	
41			

Motor Data

42	Manufacturer	Baldor		
43	Specific design	NEMA 3 ph TEPE [STD]		
44	Type	Frame 365TCZ - 75 hp		
45	Rated power	75 hp	Item no.	
46	Nominal speed	3600 rpm	Service factor	1.15
47	Frame size	365TCZ	Electric voltage	460 V
48	Weight	lb 985.0		

Base Plate

49	Name	Remarks		
50	Weight	lb		

Project	Project ID	Created by	Created on	Last update
			09-04-19	

03SH08B75T3F2

Performance Curve

Company
Contact
Tel.
E-mail

	Ø inch	Delivered Flow Application Range			Lift Capability		Shaft Power P2			Frequency		Hz	60
		Min. US g.p.m.	Max. US g.p.m.	η Max. US g.p.m.	H(Q=0) ft	η Max. ft	P2(Q=0) hp	Max. hp	η Max. hp	Operating speed rpm	Nominal flow US g.p.m.		
Is	8.687	200	1080	849	310	251		69.2	68.3	Nominal head	ft	0	
Min.	5.500	/	/	522	108	73.4		/	7.78	Inlet pressure	psi	0	
Max.	9.062	/	/	945	339	267		/	76.7	Static head	ft	0	

Power data referred to:

Water [100%] ; 39.2°F; 62.4lb/ft³; 1.69E-5ft²/s

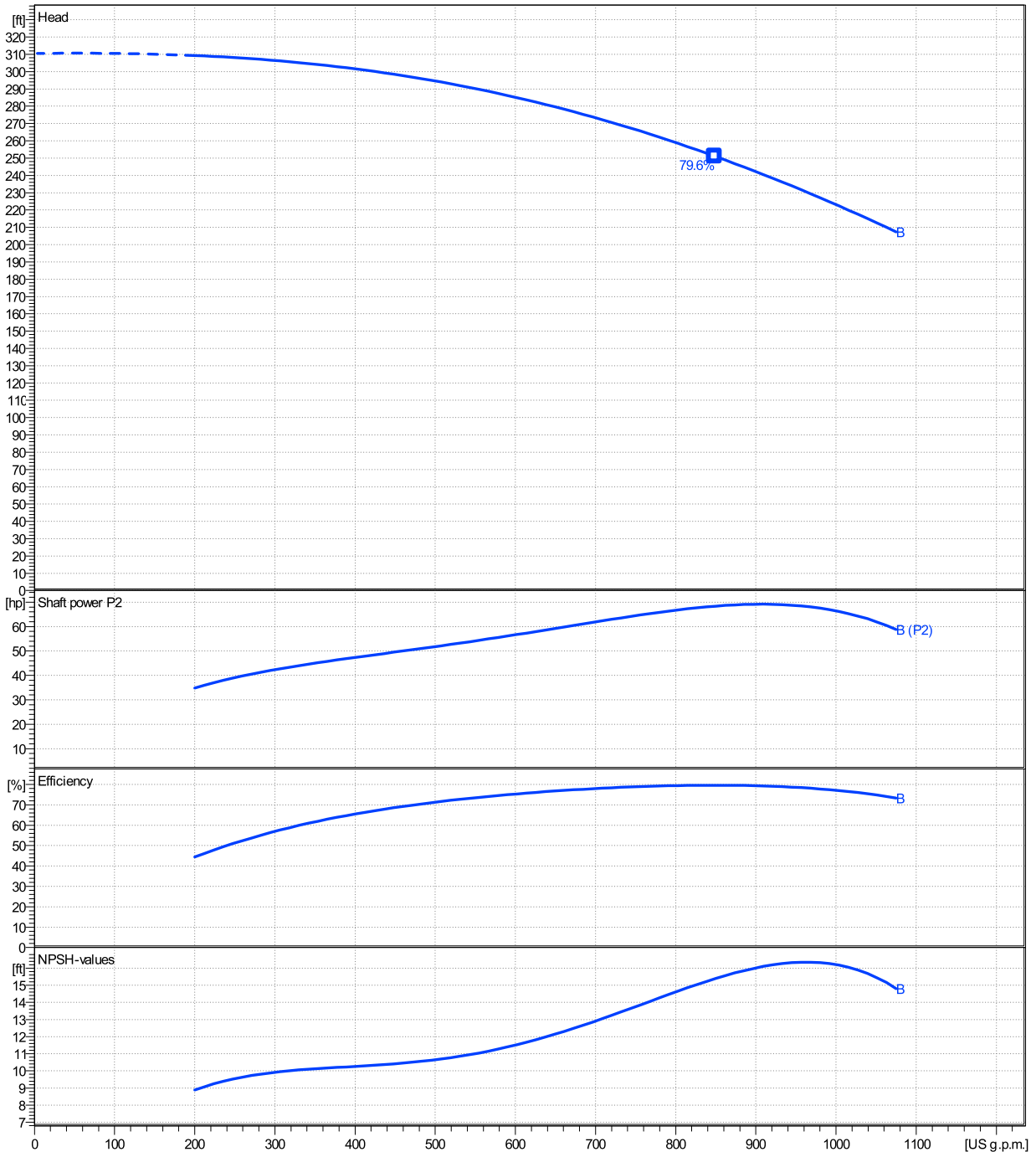

Project	Project ID	Created by	Created on 09-04-19	Last update
---------	------------	------------	------------------------	-------------

03SH08B75T3F2

Dimensions

Company
Contact
Tel.
E-mail

Close coupled
Rotation: 12 oClock [STD]
NEMA 3 ph TEPE [STD]Frame 365TCZ - 75 hp

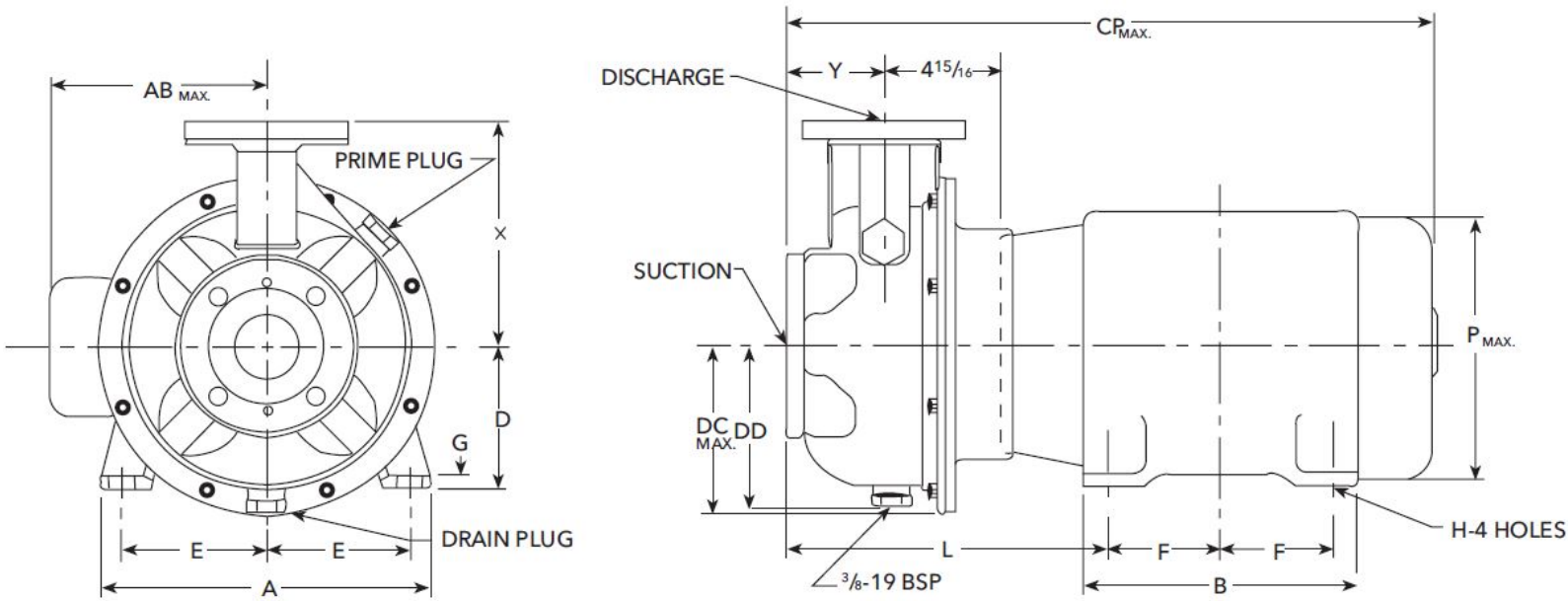

Dimensions		[inch]	
CPmax	38 1/4		
DCmax	6 7/8		
DD	6 5/8		
L	14 1/2		
X	10		
Y	5		

Connections	
Suction	Discharge port
NPS 4	NPS 3
CL150	CL150
ASME B16.5 (e-SH)	ASME B16.5 (e-SH)
Weight (+/- 5%)	
Pump	136 lb
Base Plate	
Motor	985 lb
Total weight	On demand lb

Note: Drawing not to be used for construction purposes. Weights subject to change.

Project	Project ID	Created by	Created on 09-04-19	Last update
---------	------------	------------	------------------------	-------------