

## 02SH08E20T2

### Technical Data

Company  
Contact  
Tel.  
E-mail

#### Operating Data

1	Pump type	Single head pump	Fluid	Water
2	No. of pumps	1	Operating temperature t A	°F 39.2
3	Nominal flow	US g.p.m. 0	pH-value at t A	7
4	Nominal head	ft 0	Density at t A	lb/ft <sup>3</sup> 62.4
5	Static head	ft 0	Kin. viscosity at t A	ft <sup>2</sup> /s 1.689E-5
6	Inlet pressure	psi 0	Vapor pressure at t A	psi 14.5
7	Environmental temperature	°F 68	Content of solid%	Solid size inch 0 0
8	Available system NPSH	ft 0	Altitude	ft 0

#### Pump Data

9	Design	Highly efficient stainless steel end suction pumps		
10	Execution	Rotation: 12 oClock [STD]		
11	Operating speed	rpm 3500	Impeller Ø	Max. inch 8 1/4
12	Group	S		Designed inch 6 7/8
				Min. inch 6 3/16
13	Suction	NPS 2.5 / CL150 / ASME B16.5 (e-SH)		
14	Discharge port	NPS 2 / CL150 / ASME B16.5 (e-SH)		
15	Max. casing pressure	psi	Flow	Nominal US g.p.m.
16	Max. working pressure	psi 83.7		Max- US g.p.m. 345
17	Impeller type	Radial impeller		
18	Head H(Q=0)	ft 190	Head	at Qmax ft 120.1
19	Max. shaft power	hp 16.7		at Qmin ft 192.7
20	Pump weight	lb 68.0	Shaft power	hp
21	Total weight	lb On demand	Efficiency	%
			NPSH 3%	ft

#### Materials

Pump		Shaft Seal	
23	Casing	Stainless steel 316L	John Crane Elastomer Bellows Shaft Seal
24	Impeller	Stainless steel 316L	Type 21
25	Wear Ring	Stainless steel 316L	Seal faces Carbon [STD]
26	Adapter	Gray cast iron class 20B	Stationary ring Silicon Carbide
27	Ball bearing (outboard)	Steel	Elastomers FKM
28	Pump shaft	Steel grade 1213	Springs Stainless steel 316
29	Deflector	Buna-N	Other metal parts Stainless steel 316
30	Shaft sleeve	Stainless steel 316	
31	Bearing Cover	Gray cast iron class 20B	
32	Ball bearing (inboard)	Steel	
33	Impeller Key	Steel	
34	Seal Housing	Stainless steel 316L	
35	Impeller Washer	Stainless steel CF8M	
36	Bearing Frame	Gray cast iron class 20B	
37	Lip Seal	Not available	
38	V-Ring	Buna-N	
39	Casing bolt with nut (casing to adapter)	Stainless Steel	
40	Retaining ring	Steel	
41			

#### Motor Data

42	Manufacturer	Baldor		
43	Specific design	NEMA 3 ph TEPE [STD]		
44	Type	Frame 256JM - 20 hp		
45	Rated power	0 hp	Item no.	
46	Nominal speed	0 rpm	Service factor	1.15
47	Frame size	256JM	Electric voltage	0 V
48	Weight	lb 263.0		

#### Base Plate

49	Name	Remarks		
50	Weight	lb		

Project	Project ID	Created by	Created on 08-02-19	Last update
---------	------------	------------	------------------------	-------------

## 02SH08E20T2

### Performance Curve

Company  
Contact  
Tel.  
E-mail

	Ø inch	Delivered Flow			Lift Capability		Shaft Power P2			Frequency		Hz	60
		Application Range Min. US g.p.m.	Max. US g.p.m.	η Max. US g.p.m.	H(Q=0) ft	η Max. ft	P2(Q=0) hp	Max. hp	η Max. hp	Operating speed rpm	Nominal flow US g.p.m.		
Is	6.875	70	345	237	193	162		16.7	14.8	Nominal head	ft	0	
Min.	6.187	/	/	222	156	135		/	12	Inlet pressure	psi	0	
Max.	8.250	/	/	302	275	210		/	21.2	Static head	ft	0	

**Power data referred to:**

Water [100%] ; 39.2°F; 62.4lb/ft³; 1.69E-5ft²/s

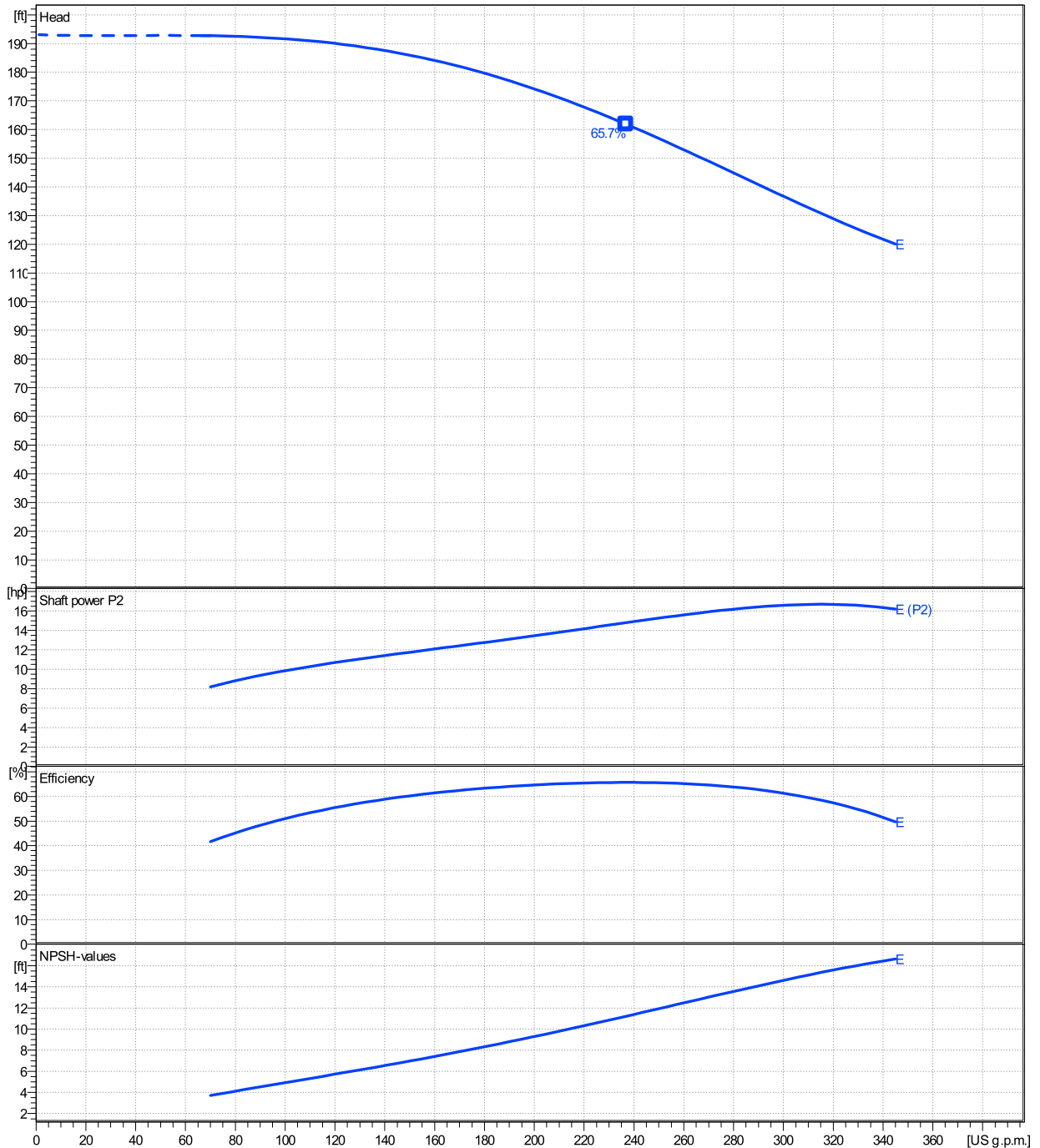

Project	Project ID	Created by	Created on 08-02-19	Last update
---------	------------	------------	------------------------	-------------

**02SH08E20T2**

**Dimensions**

Company  
Contact  
Tel.  
E-mail

Close coupled  
Rotation: 12 oClock [STD]  
NEMA 3 ph TEPE [STD]Frame 256JM - 20 hp

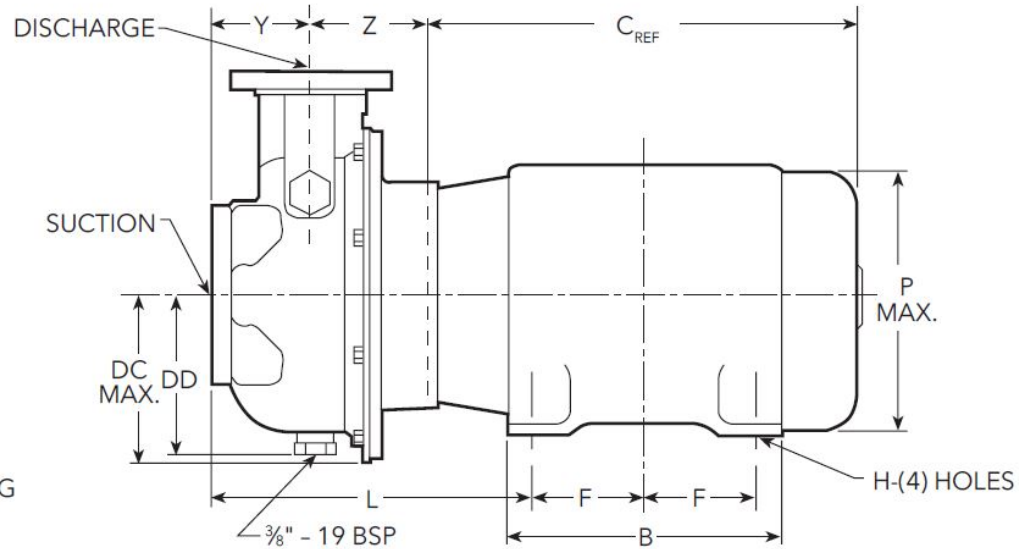
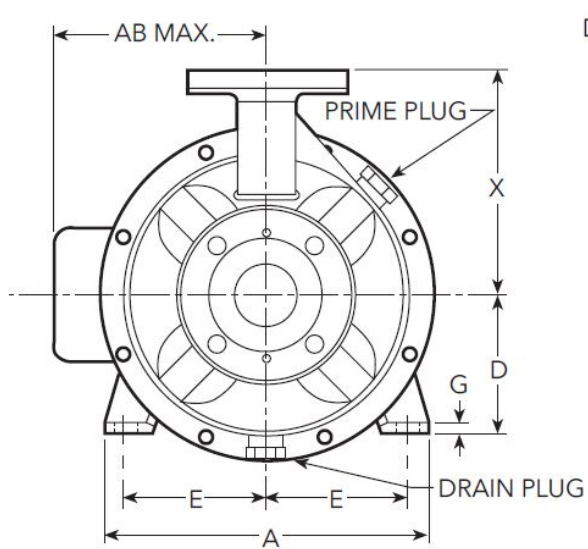

Dimensions		[ inch ]	
A	11 <sup>1</sup> / <sub>2</sub>		
ABmax	12 <sup>3</sup> / <sub>8</sub>		
B	11 <sup>1</sup> / <sub>2</sub>		
Cref	20 <sup>3</sup> / <sub>4</sub>		
D	6 <sup>1</sup> / <sub>4</sub>		
DCmax	6		
DD	5 <sup>3</sup> / <sub>4</sub>		
E	5		
F	5		
G	1 <sup>1</sup> / <sub>4</sub>		
H	1 <sup>1</sup> / <sub>2</sub>		
L	12 <sup>1</sup> / <sub>8</sub>		
Pmax	13 <sup>3</sup> / <sub>8</sub>		
X	7 <sup>15</sup> / <sub>16</sub>		
Y	4		
Z	3 <sup>5</sup> / <sub>8</sub>		

Connections	
<b>Suction</b>	<b>Discharge port</b>
NPS 2.5	NPS 2
CL150	CL150
ASME B16.5 (e-SH)	ASME B16.5 (e-SH)
Weight (+/- 5%)	
<b>Pump</b>	68 lb
<b>Base Plate</b>	
<b>Motor</b>	263 lb
<b>Total weight</b>	<b>On demand lb</b>

Note: Drawing not to be used for construction purposes. Weights subject to change.

Project	Project ID	Created by	Created on 08-02-19	Last update
---------	------------	------------	------------------------	-------------