

PROJECT: _____	UNIT TAG: _____	QUANTITY: _____
REPRESENTATIVE: _____	TYPE OF SERVICE: _____	DATE: _____
ENGINEER: _____	SUBMITTED BY: _____	DATE: _____
CONTRACTOR: _____	APPROVED BY: _____	DATE: _____
	ORDER NO.: _____	DATE: _____



SEG.A20.40.EX.2.60H

Grinder pumps

Product photo could vary from the actual product

Conditions of Service	Pump Data	Motor Data
Flow: _____	Maximum operating pressure: 87.02 psi	Rated voltage: 460 V
Head: _____	Liquid temperature range: 32 .. 104 °F	Main frequency: 60 Hz
Efficiency: _____	Maximum ambient temperature: 104 °F	Number of poles: 2
Liquid: any viscous fluid	Approvals: PA-I, ATEX	Enclosure class: IP68
Temperature: _____	Flange standard: ANSI	Insulation class: F
NPSH required: ft	Product number: 98280892	Motor protection: THERMAL SWITCH
Viscosity: _____		Thermal protection: external
Specific Gravity: 1.000		

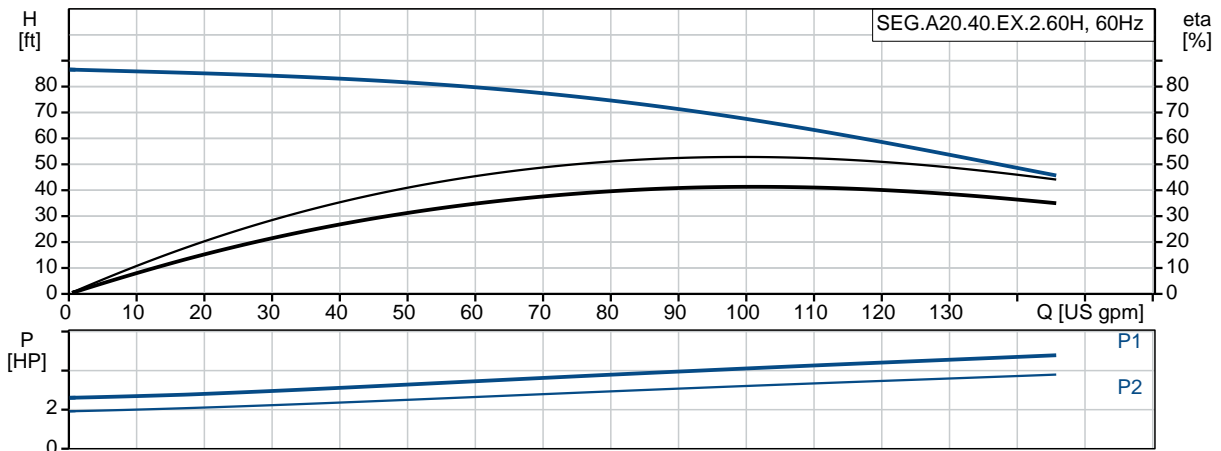

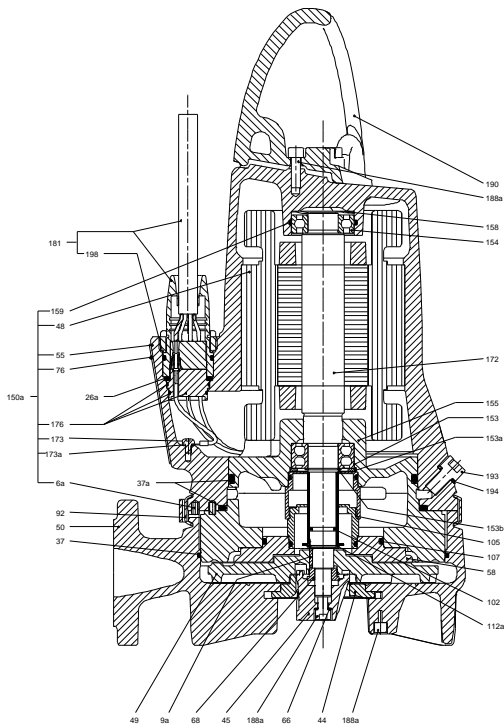
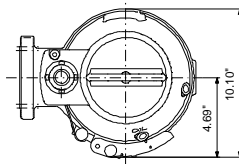
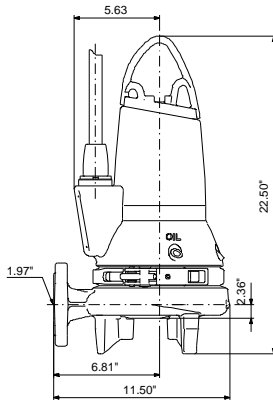

Materials:

Pump housing: Cast iron
EN1561 EN-GJL-200
ASTM A48 30B

Impeller: Cast iron
EN1561 EN-GJL-200
ASTM A48 30B

Count	Description
1	<p data-bbox="298 415 552 443">SEG.A20.40.EX.2.60H</p>  <p data-bbox="686 911 1138 932">Product photo could vary from the actual product</p> <p data-bbox="298 940 561 968">Product No.: 98280892</p> <p data-bbox="298 999 1386 1100">Non-self-priming, single-stage, centrifugal pump with horizontal discharge port, specifically designed for lift and pumping of wastewater containing discharge from toilets. The pump is equipped with a grinder system that grinds destructible solids into small pieces so that they can be led away through pipes of a relatively small diameter.</p> <p data-bbox="298 1113 1414 1188">The surface of the pump is smooth to prevent dirt and impurities from sticking to the pump. A corrosion resistant stainless steel clamp is securing the motor to the pump housing and allow for ease of service of the pump.</p> <p data-bbox="298 1201 1349 1251">For maintaining maximum pump efficiency during the pump life, a SmartTrim system allows easy adjustment of impeller clearance.</p> <p data-bbox="298 1285 613 1314">Further product details</p> <p data-bbox="298 1323 1403 1373">This grinder pump is specially designed for pumping effluent and untreated domestic sewage in areas with no sewer system or where gravitation systems are unsuitable.</p> <p data-bbox="298 1381 1094 1409">The pump is designed for transfer of domestic and municipal wastewater:</p> <ul data-bbox="337 1413 711 1526" style="list-style-type: none">- in sparsely populated areas- in small villages and farms- in areas of difficult topography- in areas with high groundwater <p data-bbox="298 1560 1386 1610">The pump can also remove industrial wastewater containing fibres in industrial applications, such as washing plants.</p> <p data-bbox="298 1644 380 1673">Pump</p> <p data-bbox="298 1682 1252 1732">The pump is primarily made of cast iron with surface treatment of powder coating: black NCS9000N/RAL 9005, gloss 30, thickness 100 µ.</p> <p data-bbox="298 1740 1373 1791">The pump features a patented grinder system, ensuring extremely high efficiency and reliable operation. Quick and easy dismantling for replacement of wear parts. No special tools are required.</p>



A stainless-steel clamp connection between motor and pump housing ensures easy inspection and service of the impeller and shaft seal.

The shaft seal consists of a cartridge seal that ensures a reliable sealing between pumped liquid and motor.

- Primary seal: silicon carbide/silicon carbide (SiC/SiC) mechanical shaft seal
- Secondary seal: lip seal

In connection with service, the mechanical shaft seal and the lip seal are supplied as one unit ready for fitting.



This pump is equipped with the unique SmartTrim system that enables you to easily restore the factory-set impeller clearance and maintain peak pumping efficiency. To do this, remove the cutter head and adjust the SmartTrim nut on the impeller. This can be done on site without dismantling the pump and without using special tools.

The pump has been tested and approved by CSA.

Motor

The motor is a watertight, totally encapsulated motor, supplied with a 33 ft power cable. The stainless-steel plug is fastened with a union nut. This nut and O-rings provide sealing against ingress of the liquid. The plug is polyurethane-embedded, ensuring a watertight and durable seal around the leads of the cable. This prevents the ingress of water into the motor through the cable in case of cable breakage or adverse handling in connection with installation or service.

The motor construction is compact with a short shaft. This reduces vibrations, resulting in an increased efficiency and life of the shaft seal and ball bearings. The motor has two thermal switches in the motor windings to protect the motor against overheating.

Controls:

Moisture sensor: with moisture sensors
AUTOADAPT: NO

Liquid:

Pumped liquid: any viscous fluid
Liquid temperature range: 32 .. 104 °F
Density: 62.29 lb/ft³

Technical:



Company name:

Created by:

Phone:

Date:

4/19/2019

Count	Description
	Type of impeller: Grinder System
	Primary shaft seal: SIC/SIC
	Secondary shaft seal: CARBON/CERAMICS
	Approvals on nameplate: PA-I, ATEX
	Curve tolerance: ANSI/HI11.6:2012 3B2
	Materials:
	Pump housing: Cast iron EN1561 EN-GJL-200 ASTM A48 30B
	Impeller: Cast iron EN1561 EN-GJL-200 ASTM A48 30B
	Installation:
	Maximum ambient temperature: 104 °F
	Maximum operating pressure: 87.02 psi
	Flange standard: ANSI
	Pipework connection: 2"
	Size of outlet port: 2 inch
	Pressure stage: PN 10
	Maximum installation depth: 32.8 ft
	Auto-coupling: 98245790
	Electrical data:
	Power input - P1: 3.9 kW
	Rated power - P2: 4.16 HP
	Main frequency: 60 Hz
	Rated voltage: 3 x 460 V
	Voltage tolerance: +6/-10 %
	Max starts per. hour: 30
	Rated current: 6 A
	Starting current: 43 A
	Rated current at no load: 2.1 A
	Cos phi - power factor: 0.88
	Cos phi - p.f. at 3/4 load: 0.83
	Cos phi - p.f. at 1/2 load: 0.75
	Rated speed: 3490 rpm
	Moment of inertia: 0.562 lb ft ²
	Motor efficiency at full load: 80 %
	Motor efficiency at 3/4 load: 78 %
	Motor efficiency at 1/2 load: 75 %
	Number of poles: 2
	Start. method: direct-on-line
	Enclosure class (IEC 34-5): IP68
	Insulation class (IEC 85): F
	Explosion proof: yes
	Length of cable: 33 ft
	Cable type: SEOOW 600V
	Type of cable plug: NO PLUG



Company name:
Created by:
Phone:

Date: 4/19/2019

Count	Description
	<p>Others: Net weight: 179 lb Country of origin: HU Custom tariff no.: 8413.70.2015</p>



Company name:
Created by:
Phone:

Date: 4/19/2019

98280892 SEG.A20.40.EX.2.60H 60 Hz

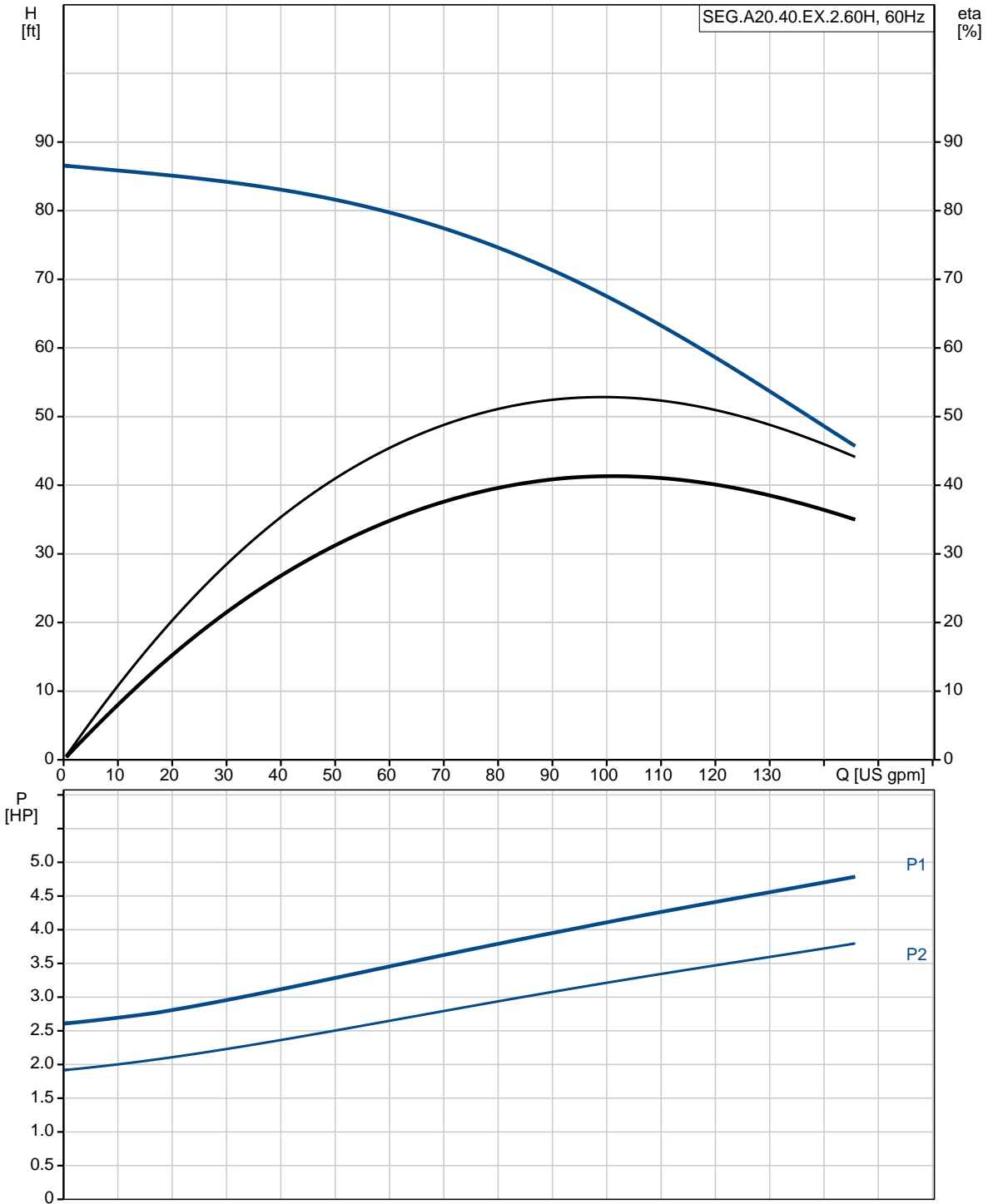



Company name:
Created by:
Phone:

Date: 4/19/2019

Description	Value
General information:	
Product name:	SEG.A20.40.EX.2.60H
Product No.:	98280892
EAN:	5711492381564
Technical:	
Max flow:	145 US gpm
Head max:	86.62 ft
Type of impeller:	Grinder System
Primary shaft seal:	SIC/SIC
Secondary shaft seal:	CARBON/CERAMICS
Approvals on nameplate:	PA-I, ATEX
Curve tolerance:	ANSI/HI11.6:2012 3B2
Materials:	
Pump housing:	Cast iron EN1561 EN-GJL-200 ASTM A48 30B
Impeller:	Cast iron EN1561 EN-GJL-200 ASTM A48 30B
Installation:	
Maximum ambient temperature:	104 °F
Maximum operating pressure:	87.02 psi
Flange standard:	ANSI
Pipework connection:	2"
Size of outlet port:	2 inch
Pressure stage:	PN 10
Maximum installation depth:	32.8 ft
Inst dry/wet:	SUBMERGED
Auto-coupling:	98245790
Liquid:	
Pumped liquid:	any viscous fluid
Liquid temperature range:	32 .. 104 °F
Density:	62.29 lb/ft ³
Electrical data:	
Power input - P1:	3.9 kW
Rated power - P2:	4.16 HP
Main frequency:	60 Hz
Rated voltage:	3 x 460 V
Voltage tolerance:	+6/-10 %
Max starts per. hour:	30
Rated current:	6 A
Starting current:	43 A
Rated current at no load:	2.1 A
Cos phi - power factor:	0.88
Cos phi - p.f. at 3/4 load:	0.83
Cos phi - p.f. at 1/2 load:	0.75
Rated speed:	3490 rpm
Moment of inertia:	0.562 lb ft ²
Motor efficiency at full load:	80 %

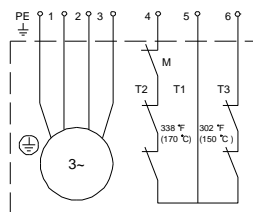
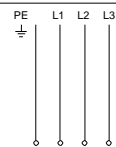
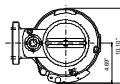
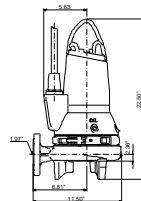
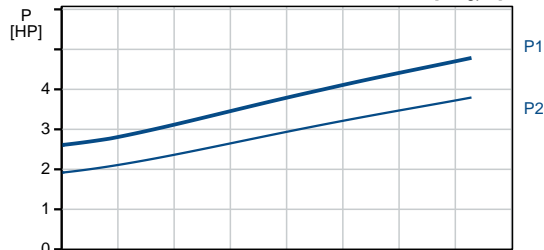
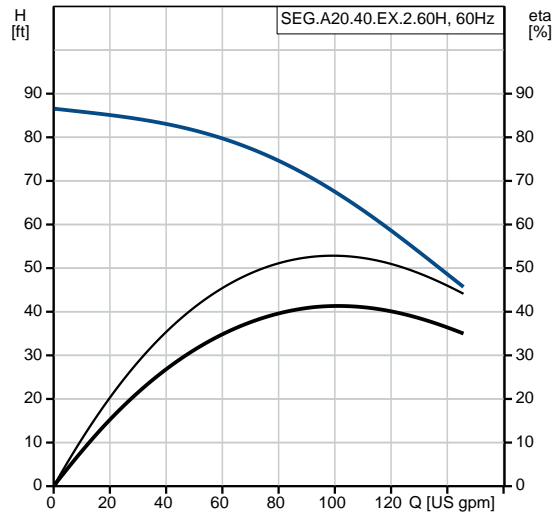



Company name:

Created by:

Phone:

Date:

4/19/2019

Description	Value
Motor efficiency at 3/4 load:	78 %
Motor efficiency at 1/2 load:	75 %
Number of poles:	2
Start. method:	direct-on-line
Enclosure class (IEC 34-5):	IP68
Insulation class (IEC 85):	F
Explosion proof:	yes
Motor protection:	THERMAL SWITCH
Thermal protec:	external
Length of cable:	33 ft
Cable type:	SEOOW 600V
Type of cable plug:	NO PLUG
Controls:	
Control box:	not included
Additional I/O:	External
Moisture sensor:	with moisture sensors
AUTOADAPT:	NO
Others:	
Net weight:	179 lb
Sales region:	Namreg
Country of origin:	HU
Custom tariff no.:	8413.70.2015



Company name:
Created by:
Phone:

Date: 4/19/2019

98280892 SEG.A20.40.EX.2.60H 60 Hz

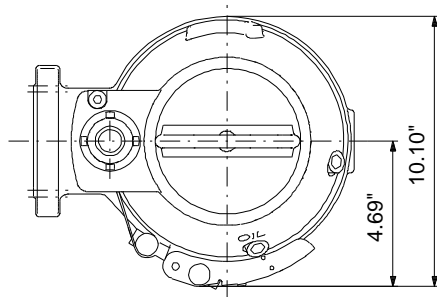
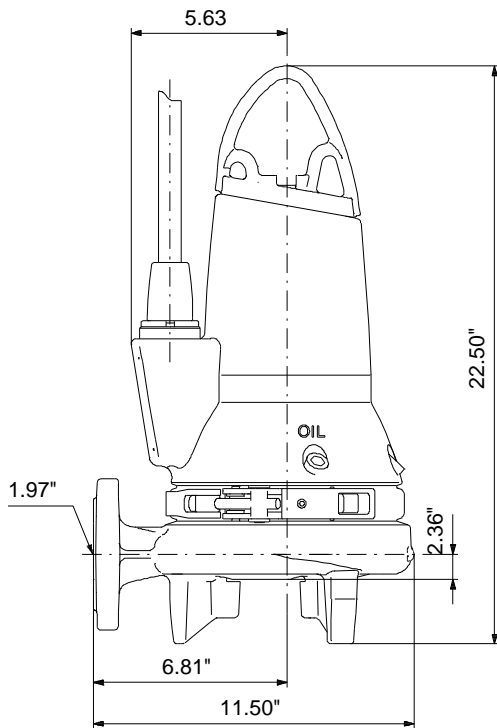

Note! All units are in [in] unless otherwise stated.
Disclaimer: This simplified dimensional drawing does not show all details.



Company name:
Created by:
Phone:

Date: 4/19/2019

98280892 SEG.A20.40.EX.2.60H 60 Hz

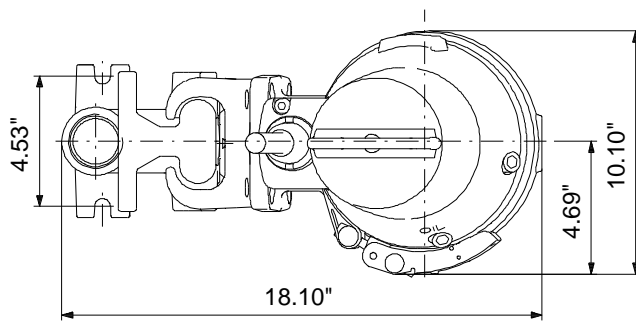
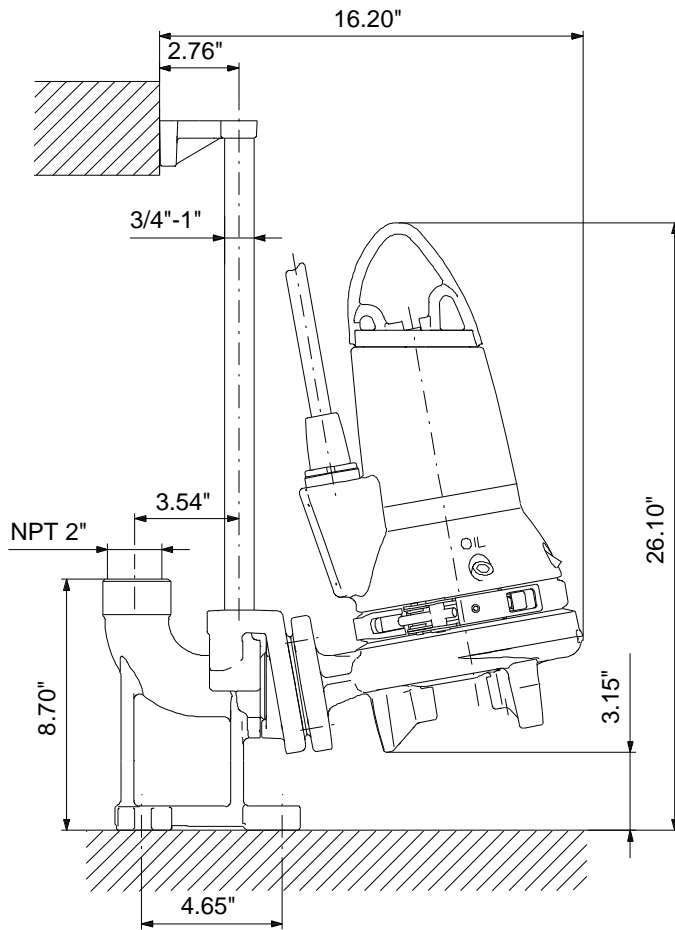

Note! All units are in [in] unless otherwise stated.
Disclaimer: This simplified dimensional drawing does not show all details.



Company name:
Created by:
Phone:

Date: 4/19/2019

98280892 SEG.A20.40.EX.2.60H 60 Hz

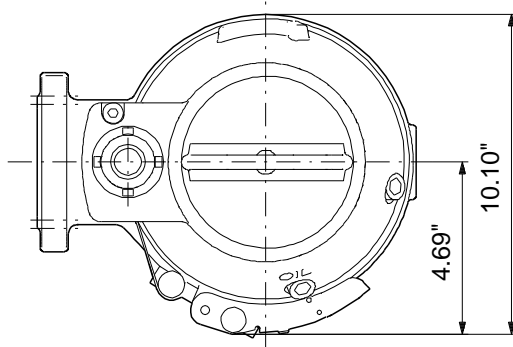
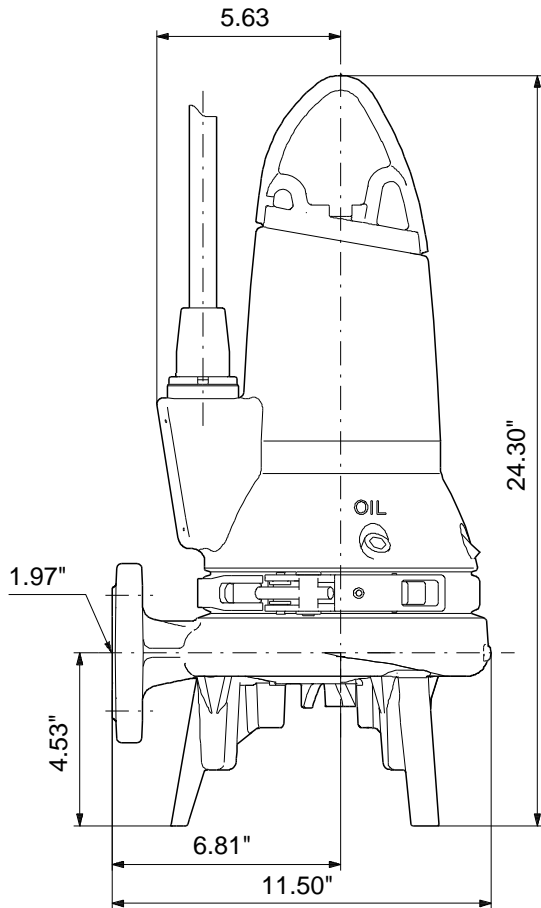

Note! All units are in [in] unless otherwise stated.
Disclaimer: This simplified dimensional drawing does not show all details.



Company name:
Created by:
Phone:

Date: 4/19/2019

98280892 SEG.A20.40.EX.2.60H 60 Hz

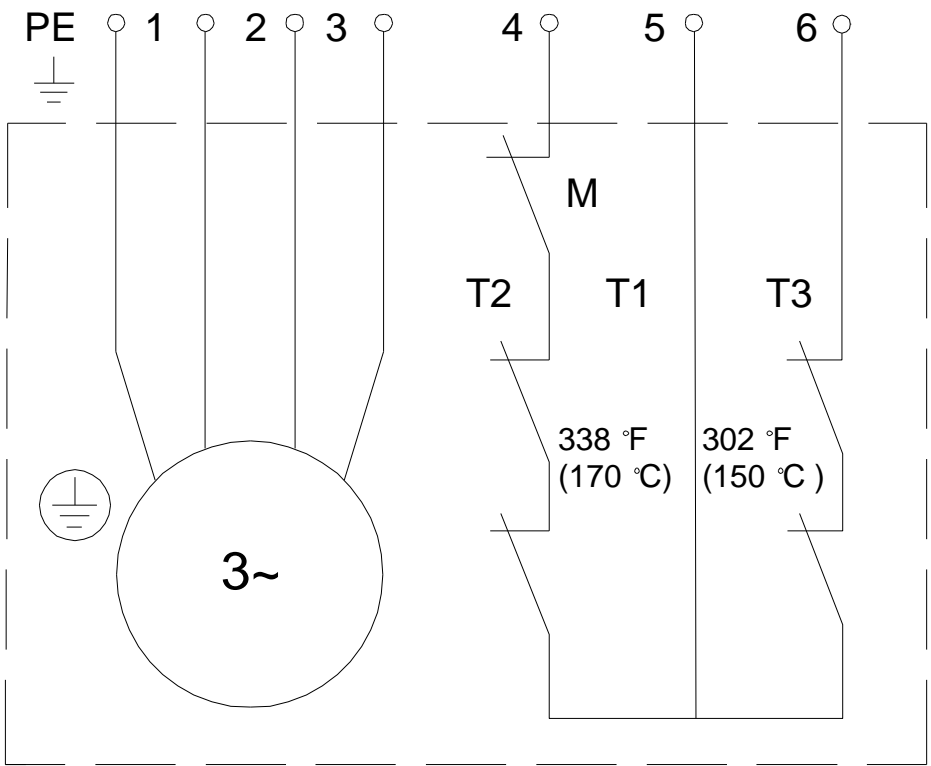
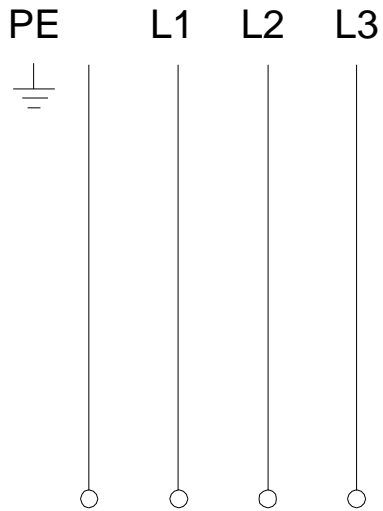

All units are [in] unless otherwise presented.