

Customer	Date	08.05.2019
Contact	Project	
Phone number	Project no.	
Email		



1SV3NA4F60

Operating Data

Pump type	Multi-Stage Pumps	Fluid	Water
No. of pumps / Reserve	1 / 0	Operating temperature t A	°F 39.2
Nominal flow	US g.p.m. 0	pH-value at t A	7
Nominal head	ft 0	Density at t A	lb/ft ³ 62.4
Static head	ft 0	Kin. viscosity at t A	ft ² /s 1.689E-5
Inlet pressure	psi 0	Vapor pressure at t A	psi 14.5
Environmental temperature	°F 68	Solids	0
Available system NPSH	ft 0	Altitude	ft 0

Pump Data

Make	Goulds Water Technology	Nominal	US g.p.m. ()
Speed	rpm 3500	Flow	Max- US g.p.m. 12.6
Number of stages	3		Min- US g.p.m.
Max. working pressure	psi 36		Nominal ft
Head H(Q=0)	ft 83	Head	at Qmax ft 46.3
Weight	lb 77		at Qmin ft 83.1
	Max. inch 0	Shaft power	hp ()
Impeller R	Designed inch 0	Max. shaft power	hp .3
	Min. inch 0	Efficiency	%
		NPSH 3%	ft

Shaft Seal

Single Seal	Xylem
Mechanical Seals	
1 - Rotating Face	Carbon
2 - Stationary Face	Silicon Carbide Graphite Filled
3 - Elastomers	Viton
4 - Spring	316SS
5 - Metal Components	316SS



Motor Data

Manufacturer	Baldor	Electric voltage	208 V	Speed	3500 rpm	Insulation class	F
Specific design	3ph TPE			Frame size	56C	Colour	RAL 5010
Type	208-230/460V 56C (V04A32E5BB3S)			Degree of protection	IP 55		
Rated power	0.5 hp	Electric current	1.6 A				

Remarks:

Customer	Date	08.05.2019
Contact	Project	
Phone number	Project no.	
Email		



~~1SV3NA4F60~~

Pump Materials

1 - Pump Body	Stainless Steel (AISI 316L)
2 - Impeller	Stainless Steel (AISI 316L)
3 - Diffuser	Stainless Steel (AISI 316L)
4 - Casing	Stainless Steel (AISI 316L)
5 - Shaft	Stainless Steel (AISI 316)
6 - Adapter	Cast Iron (ASTM Class 35/40B)
7 - Base	Aluminum (A384.0-F)
8 - Coupling	Aluminum (A384.0-F)
9 - Seal Plate	Stainless Steel (AISI 316L)
12 - Coupling Guard	Stainless Steel (AISI 304)
13 - Shaft Sleeve and Bushing	Tungsten carbide
14 - Fill/Drain Plugs	Stainless Steel (AISI 316)
15 - Tie Rods	Carbon Steel / Zinc Plated (A29 Gr. 1045)
16 - Wear Ring	PPS
17 - Seal Gland	Stainless Steel (AISI 316)

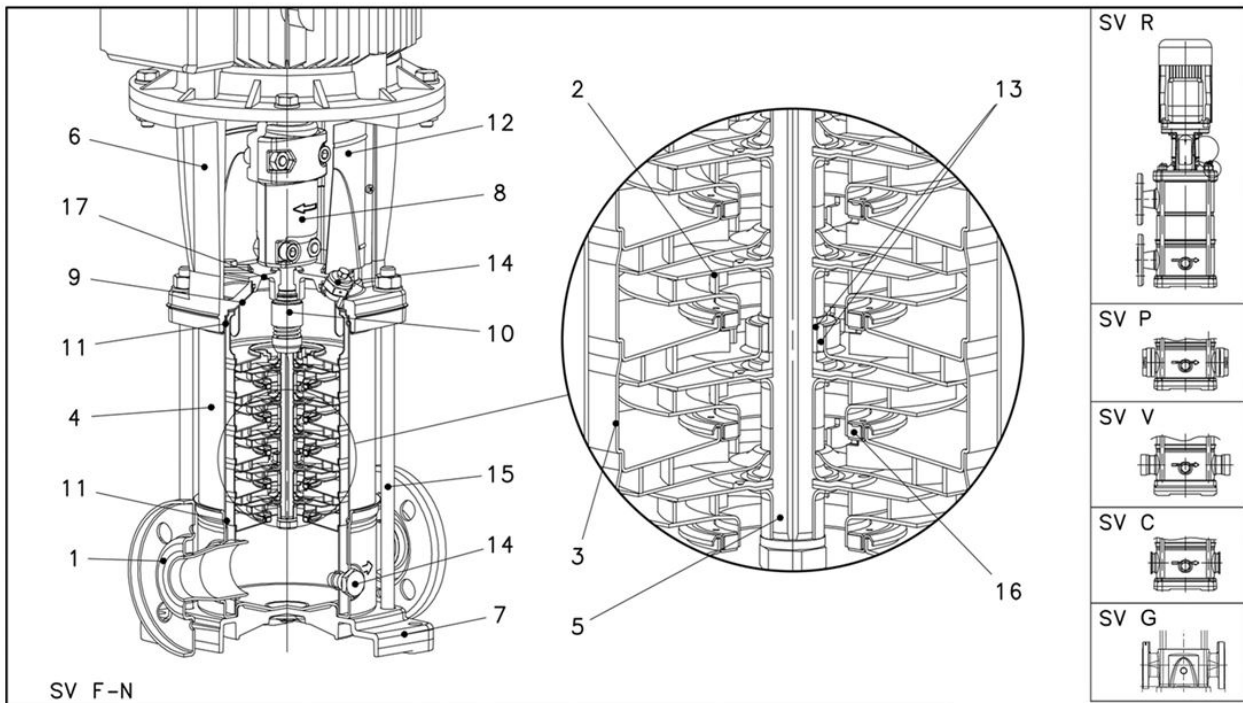

Remarks:

Customer	Date	08.05.2019
Contact	Project	
Phone number	Project no.	
Email		

~~1SV3NA4F60~~

Hydraulic Data

Operating Data Specification		Hydraulic data (duty point)		Impeller design	
Flow	0 US g.p.m.	Flow		Impeller R	"
Head	0 ft	Head		Frequency	60 Hz
Static head	0 ft			Speed	3500 rpm

Power data referred to:
 Water [100%] ; 39.2°F; 62.4lb/ft³; 1.69E-5ft²/s
 Performance according to ISO 9906 - Annex A

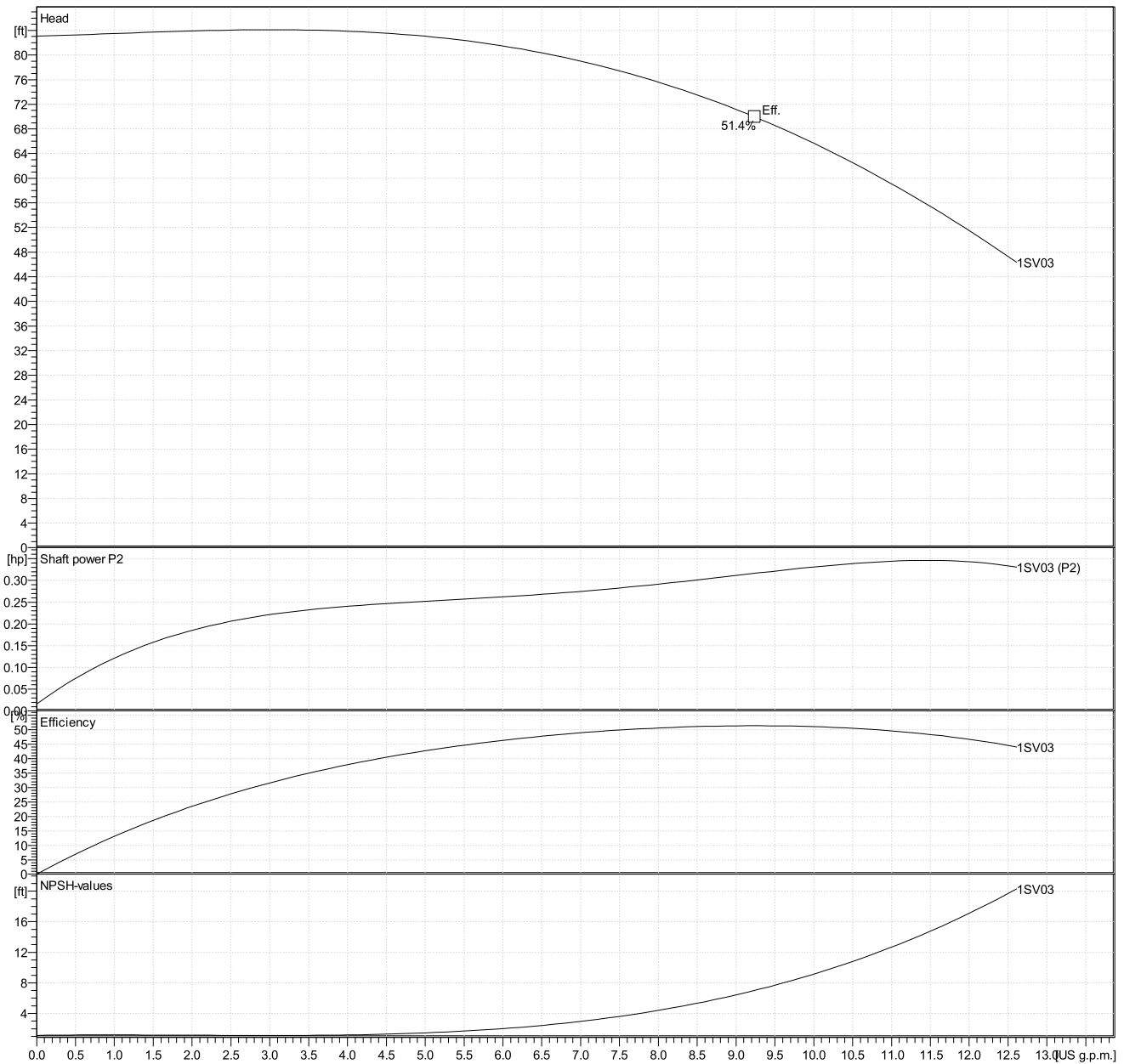

Customer	Date	08.05.2019
Contact	Project	
Phone number	Project no.	
Email		

1SV3NA4F60

Drawing



Dimensions inch

D1 max	7 ³ / ₁₆					Weight	
D2	6 ¹ / ₂					77.319	lb
L1	13 ³ / ₄						
L2	10 ⁹ / ₁₆						
L5	12 ⁹ / ₁₆						
L6	12 ⁵ / ₁₆						
M. Ref	6 ¹ / ₂						
NEMA Frame	56C						