

PROJECT: _____	UNIT TAG: _____	QUANTITY: _____
REPRESENTATIVE: _____	TYPE OF SERVICE: _____	DATE: _____
ENGINEER: _____	SUBMITTED BY: _____	DATE: _____
CONTRACTOR: _____	APPROVED BY: _____	DATE: _____
	ORDER NO.: _____	DATE: _____





CUE 3X380-500V IP54 250KW

CUE

Product photo could vary from the actual product

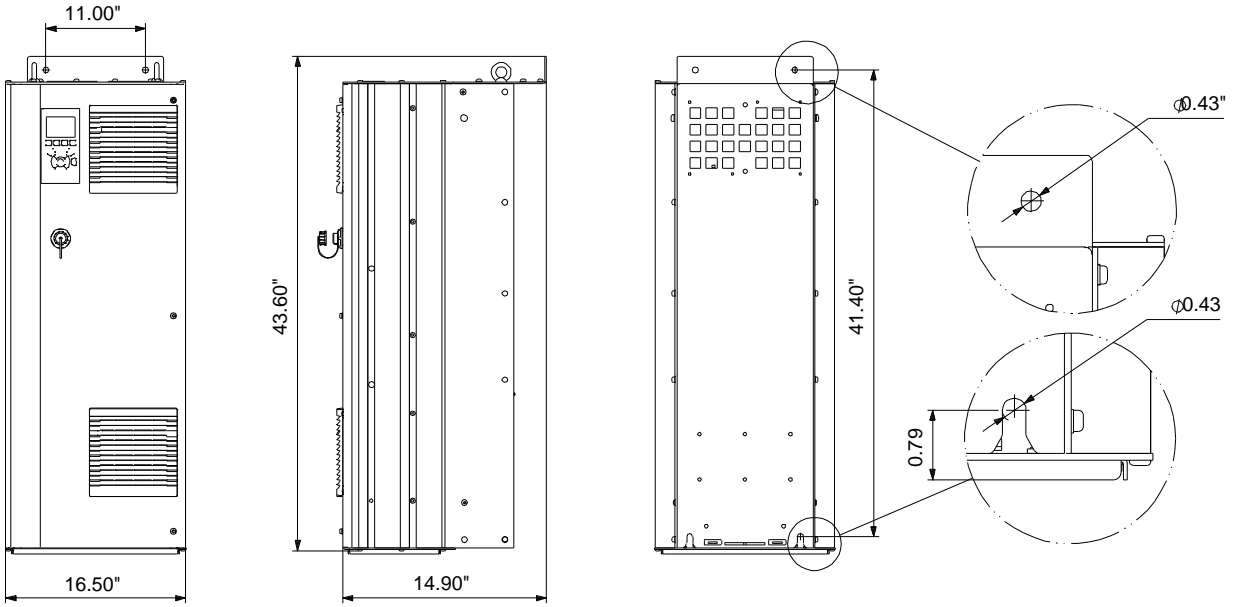
Conditions of Service	Pump Data	Motor Data
Flow: _____	Maximum ambient temperature: 104 °F	Rated voltage: 380 - 440 / 441 - 500 V
Head: _____	Approvals: CE, CULUS, C-TICK	Main frequency: 50 / 60 Hz
Efficiency: _____	Product number: On request	Enclosure class: IP54
Liquid: _____		Motor protection: YES
Temperature: _____		Thermal protection: external
NPSH required: _____		
Viscosity: _____		
Specific Gravity: _____		



Count	Description
1	<p data-bbox="298 415 641 443">CUE 3X380-500V IP54 250KW</p> <div data-bbox="418 485 555 779" style="text-align: center;">  </div> <p data-bbox="686 795 1138 821" style="text-align: center;">Product photo could vary from the actual product</p> <p data-bbox="298 827 574 852">Product No.: On request</p> <p data-bbox="298 886 1404 987">CUE is a complete range of external frequency converters designed for speed control of a wide range of Grundfos pumps. CUE has a built-in PI controller and offers the same functionality and user-interface as Grundfos E-pumps. CUE solutions can thus be seen as an extension to the E-pump range.</p> <p data-bbox="298 999 984 1024">By choosing a CUE-solution, you will get the following benefits:</p> <ul data-bbox="337 1031 1300 1203" style="list-style-type: none"> - Grundfos E-pump functionality and user-interface - application- and pump-family-related functions - increased comfort compared to fixed-speed pumps - very easy installation and commissioning compared to standard frequency converters - speed control of pumps up to 250 kW - speed control of pumps installed in potentially explosive environments. <p data-bbox="298 1236 764 1262">CUE offers the following inputs and output:</p> <ul data-bbox="337 1268 1128 1411" style="list-style-type: none"> - RS-485 GENibus - an analog 0-10 V input for external setpoint - an analog 0/4-20 mA input for sensor - four digital inputs for various functions, for instance external start/stop - two signal relays (C/NO/NC). <p data-bbox="298 1444 440 1470">Accessories:</p> <p data-bbox="298 1476 583 1501">Input/output add-on board</p> <p data-bbox="298 1507 574 1533">Provides additional input:</p> <ul data-bbox="337 1539 1300 1619" style="list-style-type: none"> - one 0/4-20 mA analog input for an additional sensor - one 0-20 mA analog output - two inputs for Pt100/Pt1000 temperature sensors, for instance for bearing monitoring. <p data-bbox="298 1652 435 1677">Motor filters:</p> <p data-bbox="298 1684 1404 1732">For reduction of dU/dt and peak voltages to the motor windings and for reduction of the acoustic noise generated in the motor, a number of motor filters are offered:</p> <ul data-bbox="337 1738 712 1795" style="list-style-type: none"> - dU/dt filters , 11-250 kW - Sine wave filters, 0.55-250 kW. <p data-bbox="298 1829 423 1854">Technical:</p> <p data-bbox="298 1860 886 1885">Approvals on nameplate: CE, CULUS, C-TICK</p>



Company name:

Created by:

Phone:

Date:

5/27/2020

Count	Description
	<p data-bbox="298 415 440 443">Installation:</p> <p data-bbox="298 445 786 472">Range of ambient temperature: 32 .. 104 °F</p> <p data-bbox="298 474 737 501">Relative humidity: 5-95 %</p> <p data-bbox="298 533 477 560">Electrical data:</p> <p data-bbox="298 562 737 590">Rated power - P2: 340 HP</p> <p data-bbox="298 592 769 619">Main frequency: 50 / 60 Hz</p> <p data-bbox="298 621 948 648">Rated voltage: 3 x 380 - 440 / 441 - 500 V</p> <p data-bbox="298 651 769 678">Rated current: 480-443 A</p> <p data-bbox="298 680 721 707">Maximum current consumption: 480 A</p> <p data-bbox="298 709 721 737">Efficiency at full load: 98 %</p> <p data-bbox="298 739 704 766">Enclosure class (IEC 34-5): IP54</p> <p data-bbox="298 798 380 825">Others:</p> <p data-bbox="298 827 721 854">Net weight: 276 lb</p>



Company name:
Created by:
Phone:

Date: 5/27/2020

Description	Value
General information:	
Product name:	CUE 3X380-500V IP54 250KW
Product No.:	On request
EAN:	On request
	On request
Technical:	
Approvals on nameplate:	CE, CULUS, C-TICK
Installation:	
Range of ambient temperature:	32 .. 104 °F
Relative humidity:	5-95 %
Mounted on:	WALL / FLOOR
Electrical data:	
Rated power - P2:	340 HP
Main frequency:	50 / 60 Hz
Rated voltage:	3 x 380 - 440 / 441 - 500 V
Rated current:	480-443 A
Maximum current consumption:	480 A
Efficiency at full load:	98 %
Enclosure class (IEC 34-5):	IP54
Motor protection:	YES
Thermal protec:	external
Cable length:	150/300 m
Others:	
Net weight:	276 lb

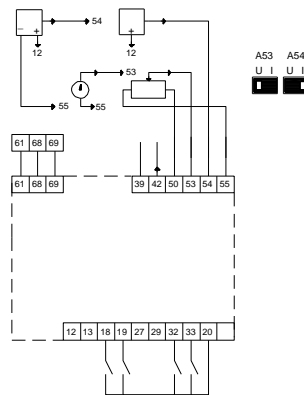
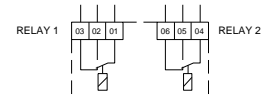
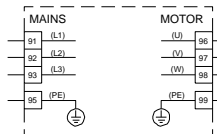
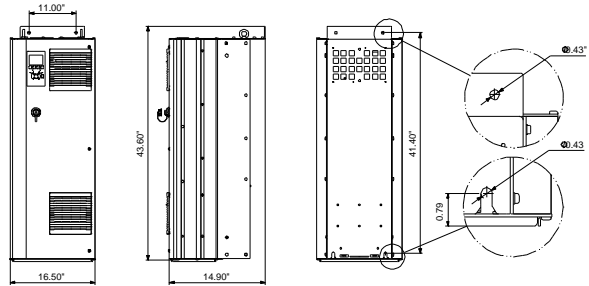



Company name:
Created by:
Phone:

Date: 5/27/2020

On request CUE 3X380-500V IP54 250KW

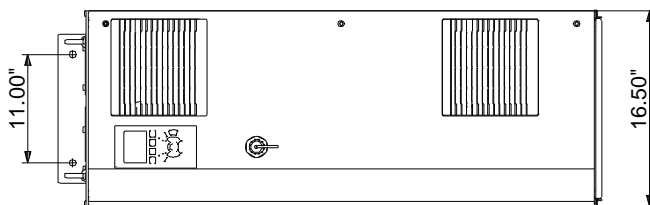
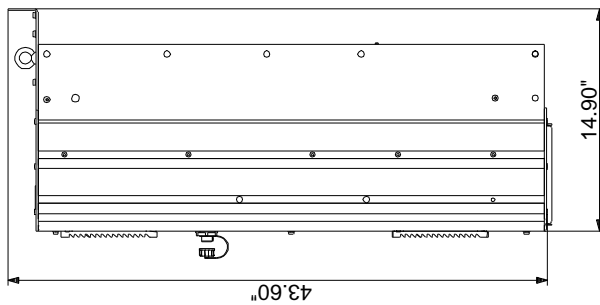
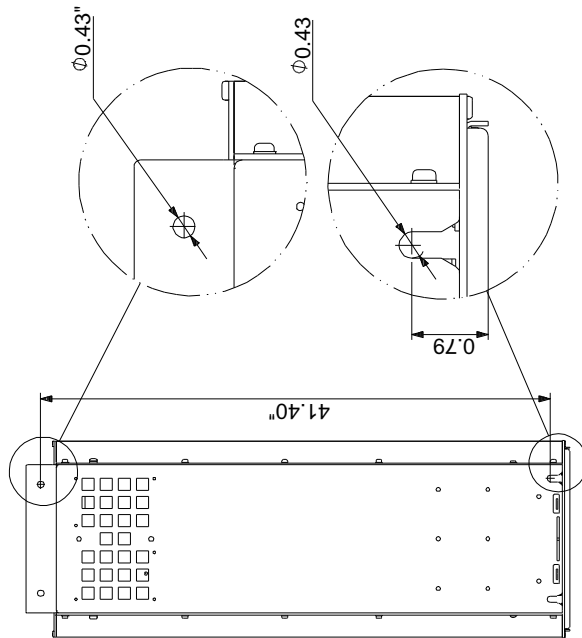

Note! All units are in [in] unless otherwise stated.
Disclaimer: This simplified dimensional drawing does not show all details.

On request CUE 3X380-500V IP54 250KW

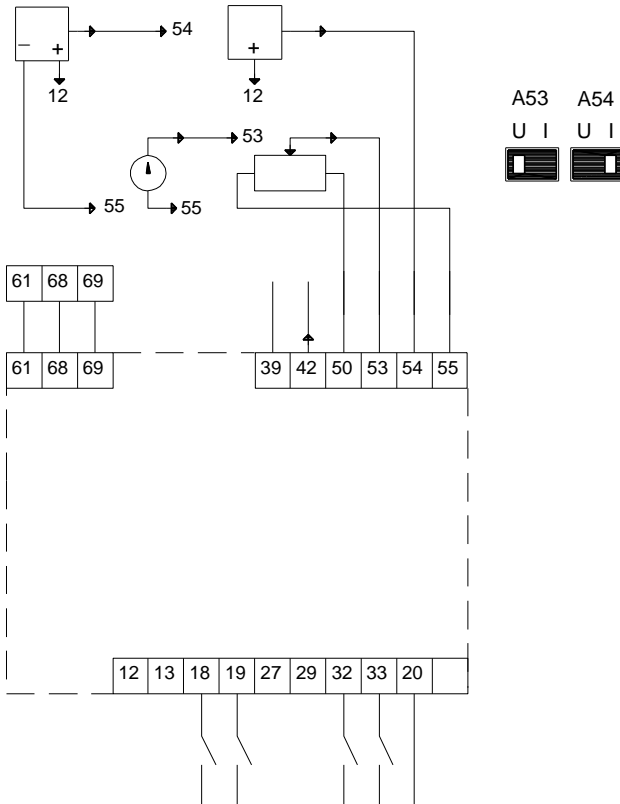
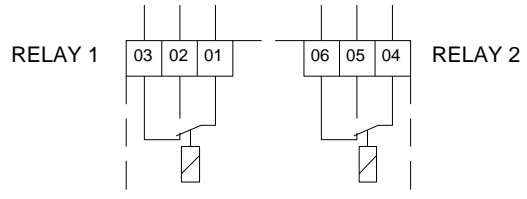
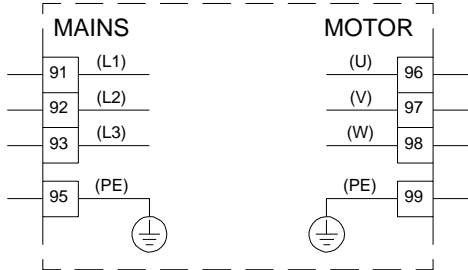

All units are [in] unless otherwise presented.