

PROJECT: _____	UNIT TAG: _____	QUANTITY: _____
REPRESENTATIVE: _____	TYPE OF SERVICE: _____	DATE: _____
ENGINEER: _____	SUBMITTED BY: _____	DATE: _____
CONTRACTOR: _____	APPROVED BY: _____	DATE: _____
	ORDER NO.: _____	DATE: _____

### CRNE 5-16 N-FGJ-A-E-HQQE

Vertical, multistage centrifugal pump with integrated frequency converter. Pump materials in contact with the liquid are in stainless steel (EN 1.4301)



Product photo could vary from the actual product

Conditions of Service	Pump Data	Motor Data
Flow: _____	Max pressure at stated temperature: 363 psi / 250 °F	Rated power - P2: 5 HP
Head: _____	Liquid temperature range: -4 .. 248 °F	Rated voltage: 200-240 V
Efficiency: _____	Maximum ambient temperature: 104 °F	Main frequency: 60 Hz
Liquid: Water	Approvals: CURUS,NSF61	Enclosure class: IP55
Temperature: 68 °F	Shaft seal: HQQE	Insulation class: F
NPSH required: _____	Product number: 99389102	Motor protection: YES
Viscosity: _____		Motor type: 112C
Specific Gravity: _____		Motor_efficiency: 90.9 %

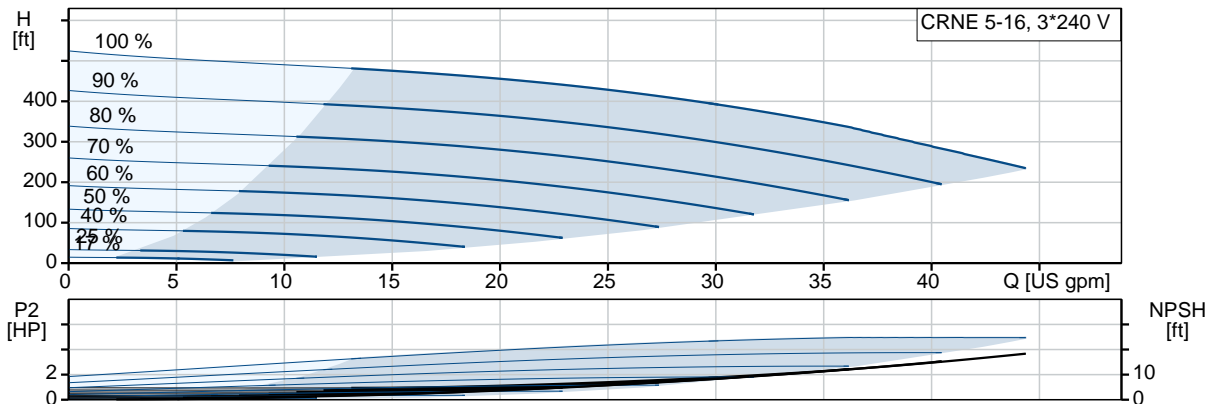

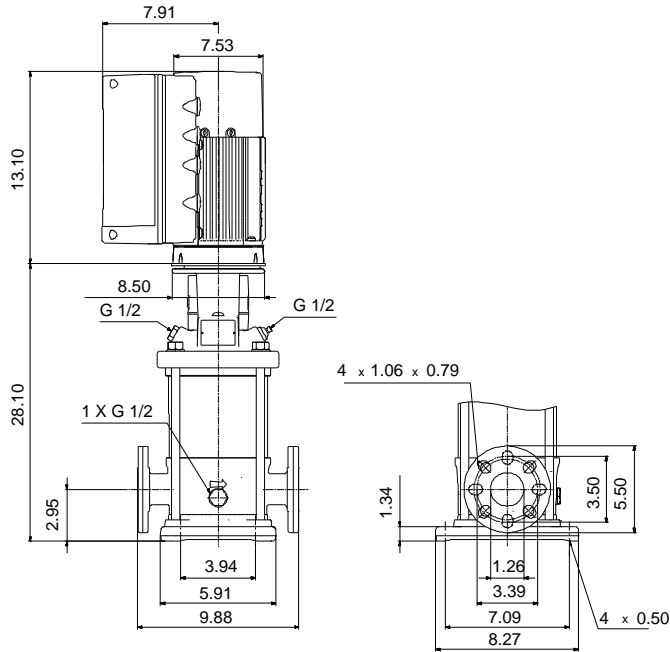

**Materials:**

Base: Stainless steel  
 EN 1.4408  
 AISI 316

Impeller: Stainless steel  
 AISI 316  
 EN 1.4401

Material code: A  
 Code for rubber: E

Count	Description
1	<p data-bbox="298 415 638 443"><b>CRNE 5-16 N-FGJ-A-E-HQQE</b></p>  <p data-bbox="298 737 561 764">Product No.: <a href="#">99389102</a></p> <p data-bbox="298 793 1414 894">Vertical, multistage centrifugal pump with inlet and outlet ports on same the level (inline). Pump materials in contact with the liquid are in high-grade stainless steel. A cartridge shaft seal ensures high reliability, safe handling, and easy access and service. Power transmission is via a rigid split coupling. Pipe connection is via combined DIN-ANSI-JIS flanges.</p> <p data-bbox="298 936 1240 963">The pump is fitted with a 3-phase, fan-cooled, permanent-magnet, synchronous motor.</p> <p data-bbox="298 968 1240 995">The pump is fitted with a 3-phase, fan-cooled, permanent-magnet, synchronous motor.</p> <p data-bbox="298 999 1125 1026">The motor efficiency is classified as IE5 in accordance with IEC 60034-30-2.</p> <p data-bbox="298 1031 1393 1131">The motor includes a frequency converter and PI controller in the motor terminal box. This enables continuously variable control of the motor speed, which again enables adaptation of the performance to a given requirement. The operating panel on the motor terminal box features a four-inch TFT display, push-buttons and the Grundfos Eye indicator.</p> <p data-bbox="298 1173 1409 1247">The display gives an intuitive and user-friendly interface to all functions. The push-buttons are used to navigate through the menu structure to access pump and performance data on site and enable setting of required setpoint as well as setting of pump to "Min." or "Max." operation or to "Stop".</p> <p data-bbox="298 1289 1382 1362">Communication with the pump is also possible by means of Grundfos GO Remote (accessory). The remote control enables further settings as well as reading out of a number of parameters such as "Actual value", "Speed", "Power input" and total "Power consumption".</p> <p data-bbox="298 1404 1305 1432">The Grundfos Eye indicator on the operating panel provides visual indication of pump status:</p> <ul data-bbox="337 1436 1403 1572" style="list-style-type: none"> <li>• "Power on": Motor is running (rotating green indicator lights) or not running (permanently green indicator lights)</li> <li>• "Warning": Motor is still running (rotating yellow indicator lights) or has stopped (permanently yellow indicator lights)</li> <li>• "Alarm": Motor has stopped (flashing red indicator lights).</li> </ul> <p data-bbox="298 1614 1349 1661">The terminal box has a number of inputs and outputs enabling the motor to be used in advanced applications where many inputs and outputs are required:</p> <ul data-bbox="337 1665 1403 1896" style="list-style-type: none"> <li>• two dedicated digital inputs</li> <li>• three analog inputs, 0(4)-20 mA, 0-5 V, 0-10 V, 0.5 - 3.5 V; the factory-fitted pressure sensor is connected to one of these inputs</li> <li>• 5 V voltage supply to potentiometer and sensor</li> <li>• one analog output, 0-10 V, 0(4)-20 mA</li> <li>• two configurable digital inputs or open-collector outputs</li> <li>• two Pt100/Pt1000 inputs</li> <li>• LiqTec, dry-running protection sensor input</li> </ul>

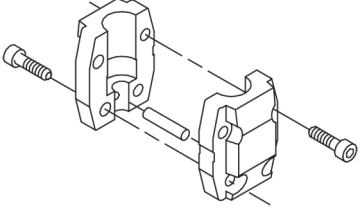
Count	Description
	<ul style="list-style-type: none"> <li>• Grundfos Digital Sensor input and output</li> <li>• 24 V voltage supply for sensors</li> <li>• two signal-relay outputs (potential-free contacts)</li> <li>• GENibus connection</li> <li>• interface for Grundfos CIM fieldbus module.</li> </ul> <p><b>Further product details</b></p> <p>The pump is equipped with a pressure sensor registering pump outlet pressure and enabling controlled pump operation based on constant pressure.</p> <p>The operating panel on the motor terminal box features a four-inch TFT display, push-buttons and the Grundfos Eye indicator.</p> <p>The display gives an intuitive and user-friendly interface to all functions. The push-buttons are used to navigate through the menu structure to access pump and performance data on site and enable setting of required setpoint as well as setting of pump to "Min." or "Max." operation or to "Stop".</p> <p>Communication with the pump is also possible by means of Grundfos GO Remote (accessory). The remote control enables further settings as well as reading out of a number of parameters such as "Actual value", "Speed", "Power input" and total "Power consumption".</p> <p>The Grundfos Eye indicator on the operating panel provides visual indication of pump status:</p> <ul style="list-style-type: none"> <li>• "Power on": Motor is running (rotating green indicator lights) or not running (permanently green indicator lights)</li> <li>• "Warning": Motor is still running (rotating yellow indicator lights) or has stopped (permanently yellow indicator lights)</li> <li>• "Alarm": Motor has stopped (flashing red indicator lights).</li> </ul> <p>Steel, cast iron and aluminium components have an epoxy-based coating made in a cathodic electro-deposition (CED) process. CED is a high-quality dip-painting process where an electrical field around the products ensures deposition of paint particles as a thin, well-controlled layer on the surface. An integral part of the process is a pretreatment. The entire process consists of these elements:</p> <ol style="list-style-type: none"> <li>1) Alkaline-based cleaning.</li> <li>2) Zinc phosphating.</li> <li>3) Cathodic electro-deposition.</li> <li>4) Curing to a dry film thickness 18-22 my m.</li> </ol> <p>The colour code for the finished product is NCS 9000/RAL 9005.</p> <p><b>Pump</b></p> <p>A standard split coupling connects the pump and motor shaft. It is enclosed in the pump head/motor stool by means of two coupling guards.</p> 

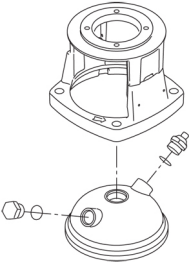
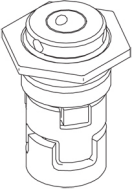
Count	Description
	<p>The pump head and flange for motor mounting is made in one piece (cast iron). The pump head cover is a separate component (stainless steel). The pump head has a combined 1/2" priming plug and vent screw.</p>  <p>The pump is fitted with a balanced O-ring seal unit with a rigid torque-transmission system. This seal type is assembled in a cartridge unit which makes replacement safe and easy. Due to the balancing, this seal type is suitable for high-pressure applications. The cartridge construction also protects the pump shaft from possible wear from a dynamic O-ring between pump shaft and shaft seal.</p> <p>Primary seal:</p> <ul style="list-style-type: none"> <li>• Rotating seal ring material: silicon carbide (SiC)</li> <li>• Stationary seat material: silicon carbide (SiC)</li> </ul> <p>This material pairing is used where higher corrosion resistance is required. The high hardness of this material pairing offers good resistance against abrasive particles.</p> <p>Secondary seal material: EPDM (ethylene-propylene rubber)            EPDM has excellent resistance to hot water. EPDM is not suitable for mineral oils.</p>  <p>The shaft seal is screwed into the pump head.</p> <p>The pump has a special air-cooled shaft-seal chamber generating the same insulation effect as that of a vacuum flask. No external cooling is necessary; the ambient temperature is sufficient. An automatic vent vents the pump seal chamber.</p> <p>The chambers and impellers are made of stainless-steel sheet. The chambers are provided with a PTFE neck ring offering improved sealing and high efficiency. The impellers have smooth surfaces, and the shape of the blades ensure a high efficiency.</p> <p>The pump has a stainless-steel base mounted on a separate base plate. This base and base plate are kept in position by the tension of the staybolts which hold the pump together. The outlet side of the base has a combined drain plug and bypass valve. The pump is secured to the foundation by four bolts through the base plate. The flanges and base are cast in one piece and prepared for connection by means of DIN, ANSI or JIS.</p> <p><b>Motor</b></p>



Company name:

Created by:

Phone:

Date:

8/27/2019

Count	Description
	<p>The motor is a totally enclosed, fan-cooled motor with principal dimensions to IEC and DIN standards. Electrical tolerances comply with IEC 60034.</p> <p>The motor efficiency is classified as IE5 in accordance with IEC 60034-30-2.</p> <p>The motor requires no external motor protection. The motor control unit incorporates protection against slow- and quick-rising temperatures, e.g. constant overload and stalled conditions.</p> <p><b>Technical data</b></p> <p><b>Controls:</b></p> <p>Frequency converter: Built-in Pressure sensor: Y</p> <p><b>Liquid:</b></p> <p>Pumped liquid: Water Liquid temperature range: -4 .. 248 °F Selected liquid temperature: 68 °F Density: 62.29 lb/ft<sup>3</sup></p> <p><b>Technical:</b></p> <p>Rated pump speed: 3461 rpm Rated flow: 30.4 US gpm Rated head: 384.2 ft Pump orientation: Vertical Shaft seal arrangement: Single Code for shaft seal: HQQE Approvals on nameplate: CURUS,NSF61 Curve tolerance: ISO9906:2012 3B</p> <p><b>Materials:</b></p> <p>Base: Stainless steel EN 1.4408 AISI 316 Impeller: Stainless steel EN 1.4401 AISI 316 Bearing: SIC</p> <p><b>Installation:</b></p> <p>Maximum ambient temperature: 104 °F Maximum operating pressure: 362.59 psi Max pressure at stated temperature: 363 psi / 250 °F 363 psi / -4 °F</p> <p>Type of connection: DIN / ANSI / JIS Size of inlet connection: DN 25/32 Size of outlet connection: DN 25/32 Pressure rating for pipe connection: PN 25 Flange rating inlet: 300 lb Flange size for motor: 182TC</p> <p><b>Electrical data:</b></p> <p>Motor standard: NEMA</p>



Company name:

Created by:

Phone:

Date:

8/27/2019

Count	Description
	Motor type: 112C
	IE Efficiency class: IE5
	Rated power - P2: 5 HP
	Power (P2) required by pump: 5 HP
	Main frequency: 60 Hz
	Rated voltage: 3 x 200-240 V
	Service factor: 1.15
	Rated current: 13.2-10.9 A
	Cos phi - power factor: 0.94
	Rated speed: 360-4000 rpm
	IE efficiency: 90.9%
	Motor efficiency at full load: 90.9 %
	Enclosure class (IEC 34-5): IP55
	Insulation class (IEC 85): F
	Motor Number: 99301701
	<b>Others:</b>
	Net weight: 109 lb
	Gross weight: 193 lb
	Shipping volume: 10.1 ft <sup>3</sup>



Company name:  
Created by:  
Phone:

Date: 8/27/2019

### 99389102 CRNE 5-16 N-FGJ-A-E-HQQE 60 Hz

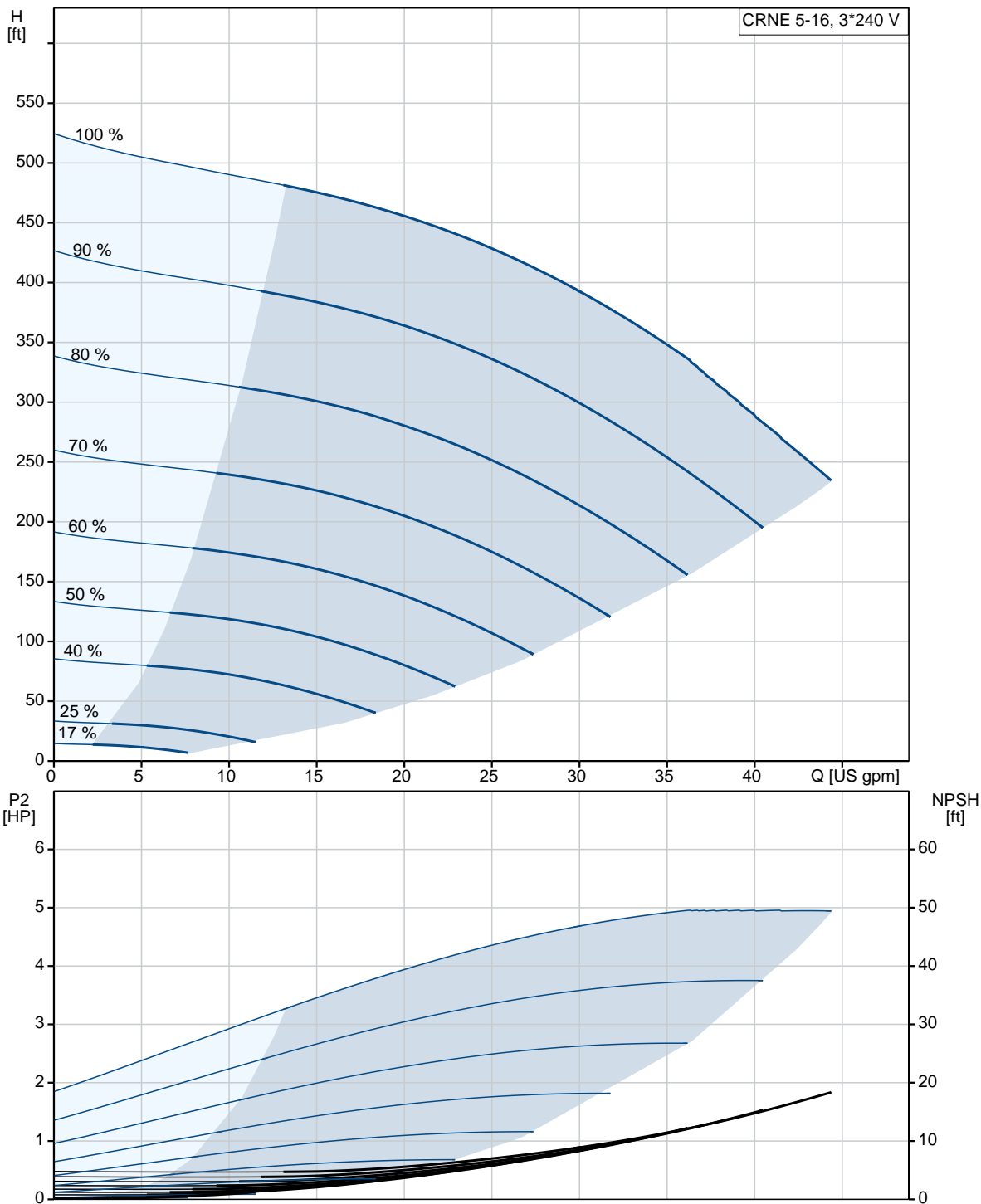





Company name:  
Created by:  
Phone:

Date: 8/27/2019

Description	Value
<b>General information:</b>	
Product name:	CRNE 5-16 N-FGJ-A-E-HQQE
Product No.:	99389102
EAN:	5713828319838 5713828319838
<b>Technical:</b>	
Rated pump speed:	3461 rpm
Rated flow:	30.4 US gpm
Rated head:	384.2 ft
Head max:	520 ft
Stages:	16
Impellers:	16
Number of reduced-diameter impellers:	0
Low NPSH:	N
Pump orientation:	Vertical
Shaft seal arrangement:	Single
Code for shaft seal:	HQQE
Approvals on nameplate:	CURUS, NSF61
Curve tolerance:	ISO9906:2012 3B
Pump version:	N
Model:	A
<b>Materials:</b>	
Base:	Stainless steel EN 1.4408 AISI 316
Impeller:	Stainless steel EN 1.4401 AISI 316
Material code:	A
Code for rubber:	E
Bearing:	SIC
<b>Installation:</b>	
Maximum ambient temperature:	104 °F
Maximum operating pressure:	362.59 psi
Max pressure at stated temperature:	363 psi / 250 °F
	363 psi / -4 °F
Type of connection:	DIN / ANSI / JIS
Size of inlet connection:	DN 25/32
Size of outlet connection:	DN 25/32
Pressure rating for pipe connection:	PN 25
Flange rating inlet:	300 lb
Flange size for motor:	182TC
Connect code:	FGJ
<b>Liquid:</b>	
Pumped liquid:	Water

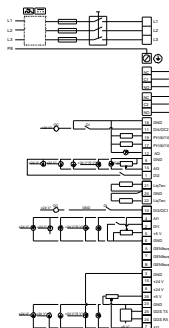
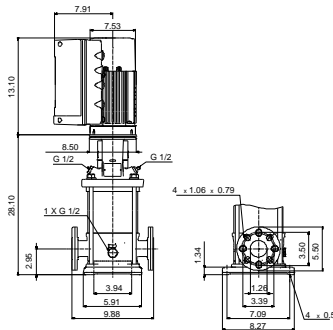
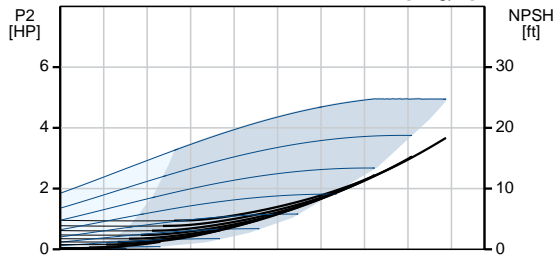
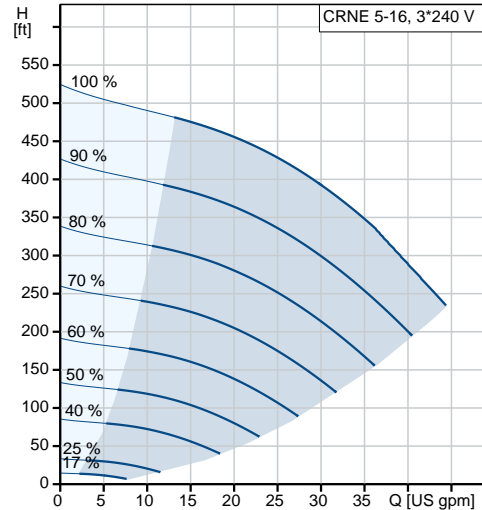



Company name:

Created by:

Phone:

Date:

8/27/2019

Description	Value
Liquid temperature range:	-4 .. 248 °F
Selected liquid temperature:	68 °F
Density:	62.29 lb/ft <sup>3</sup>
<b>Electrical data:</b>	
Motor standard:	NEMA
Motor type:	112C
IE Efficiency class:	IE5
Rated power - P2:	5 HP
Power (P2) required by pump:	5 HP
Main frequency:	60 Hz
Rated voltage:	3 x 200-240 V
Service factor:	1.15
Rated current:	13.2-10.9 A
Cos phi - power factor:	0.94
Rated speed:	360-4000 rpm
IE efficiency:	90.9%
Motor efficiency at full load:	90.9 %
Enclosure class (IEC 34-5):	IP55
Insulation class (IEC 85):	F
Motor protection:	YES
Motor Number:	99301701
<b>Controls:</b>	
Control panel:	Graphical
Function Module:	FM300 - Advanced
Frequency converter:	Built-in
Pressure sensor:	Y
<b>Others:</b>	
Net weight:	109 lb
Gross weight:	193 lb
Shipping volume:	10.1 ft <sup>3</sup>

## 99389102 CRNE 5-16 N-FGJ-A-E-HQQE 60 Hz

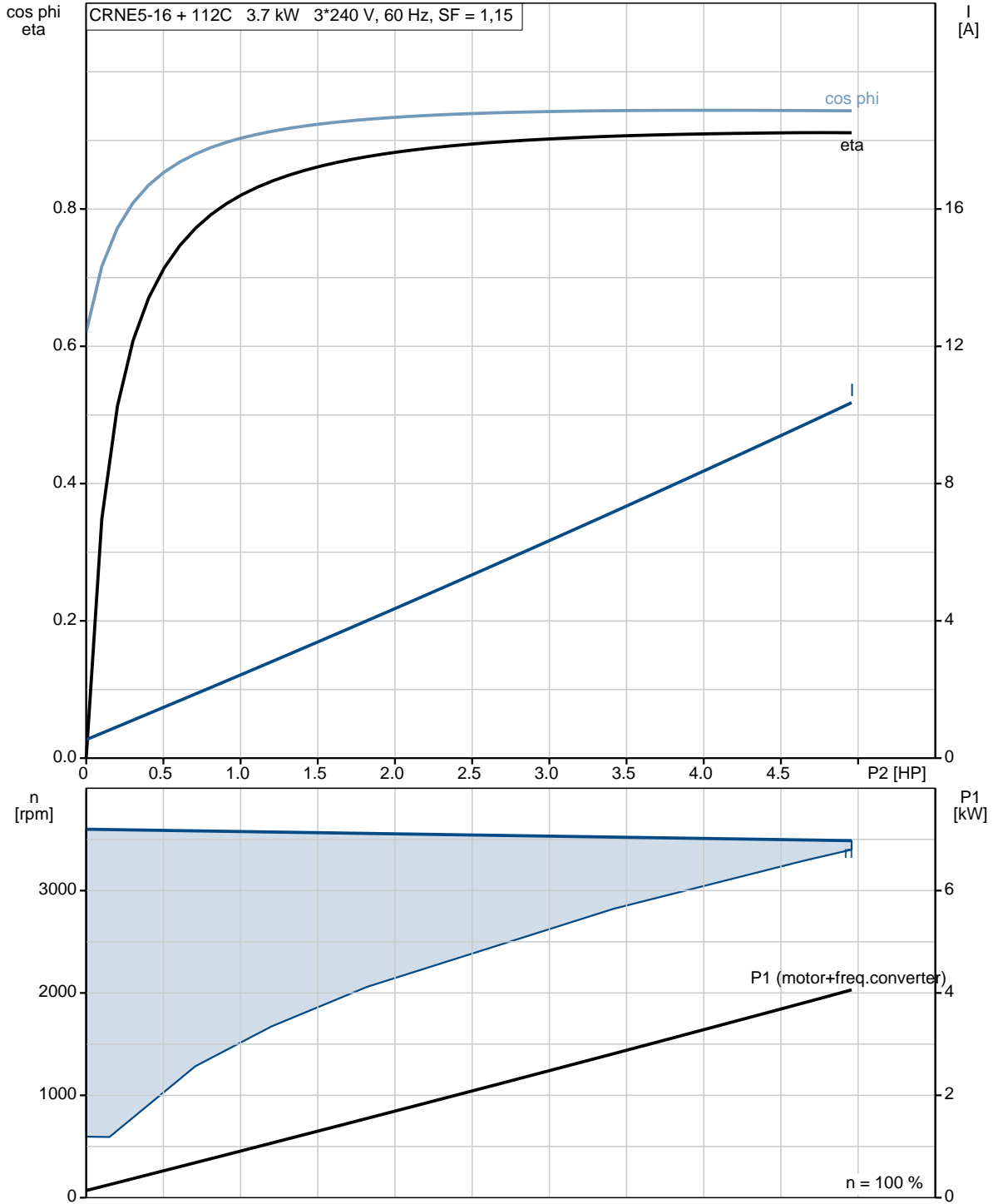



Company name:  
Created by:  
Phone:

Date: 8/27/2019

### 99389102 CRNE 5-16 N-FGJ-A-E-HQQE 60 Hz

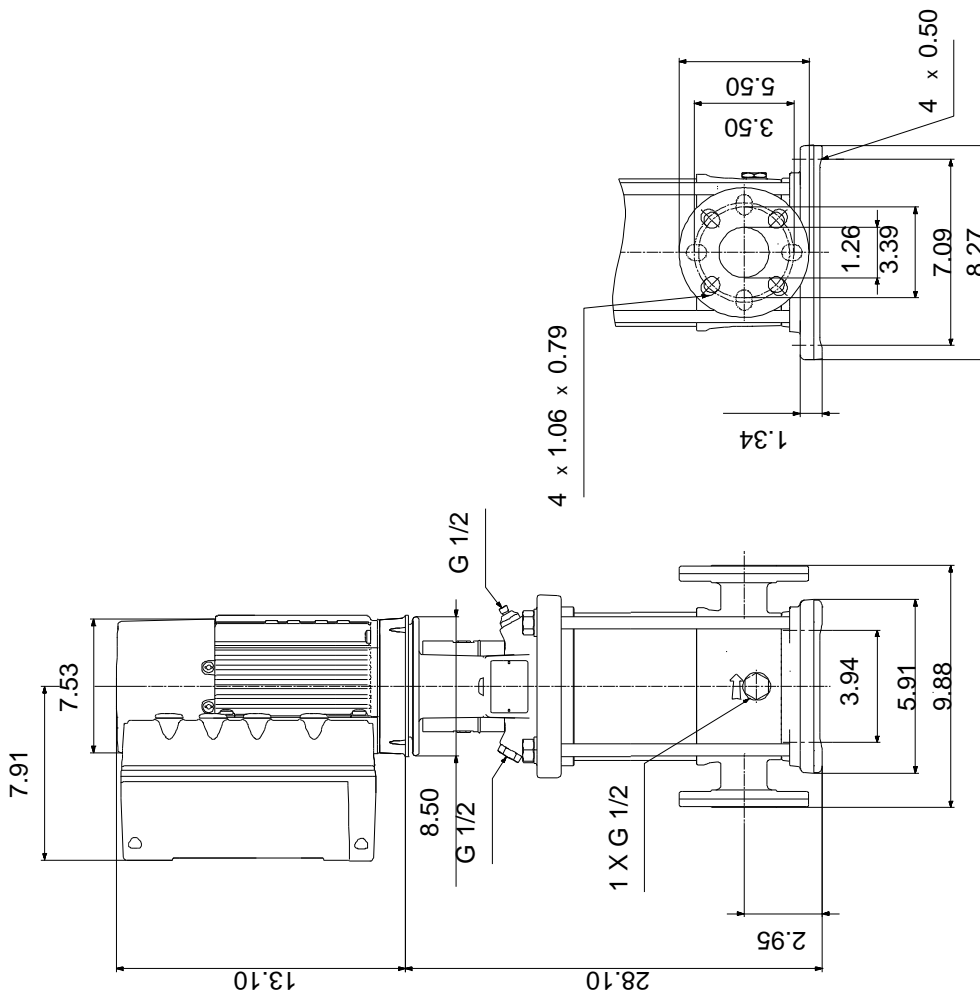

Note! All units are in [in] unless otherwise stated.  
Disclaimer: This simplified dimensional drawing does not show all details.

## 99389102 CRNE 5-16 N-FGJ-A-E-HQQE 60 Hz

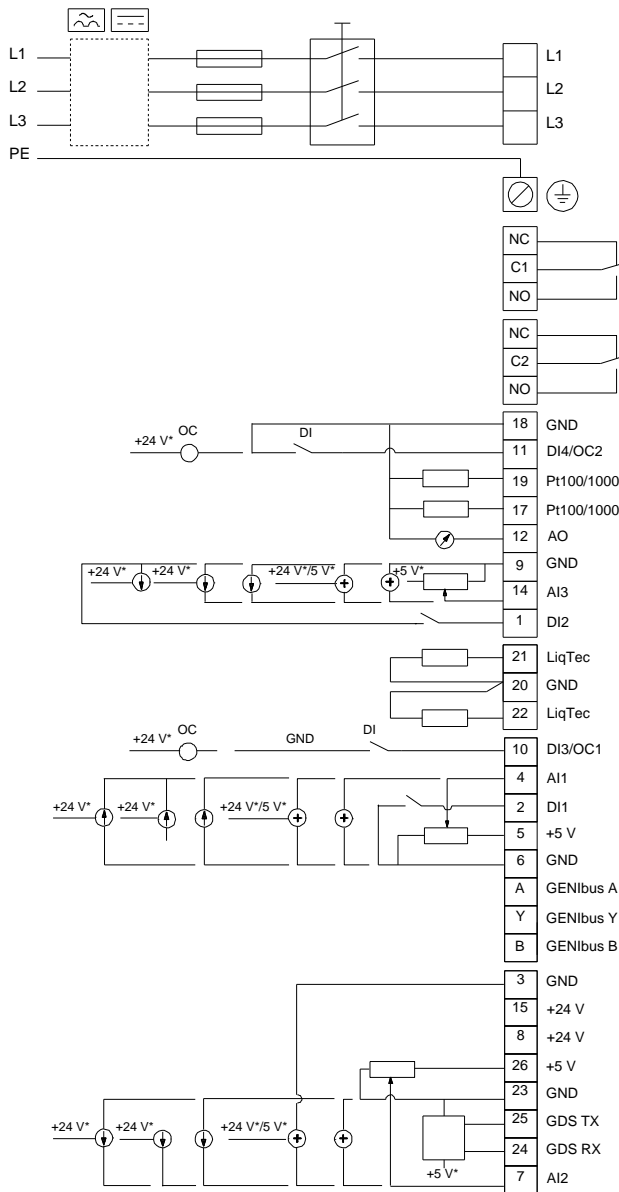

All units are [in] unless otherwise presented.