

PROJECT: _____	UNIT TAG: _____	QUANTITY: _____
REPRESENTATIVE: _____	TYPE OF SERVICE: _____	DATE: _____
ENGINEER: _____	SUBMITTED BY: _____	DATE: _____
CONTRACTOR: _____	APPROVED BY: _____	DATE: _____
	ORDER NO.: _____	DATE: _____

Unilift KP 350 M 1

Domestic drainage pumps in stainless steel for solids up to 0.39" (10 mm).



Product photo could vary from the actual product

Conditions of Service	Pump Data	Motor Data
Flow: _____	Liquid temperature range: 32 .. 113 °F	Rated voltage: 115 V
Head: _____	Approvals: UL Listed, CSA	Main frequency: 60 Hz
Efficiency: _____	Product number: 013DC201	Enclosure class: IP68
Liquid: any viscous fluid		Insulation class: F
Temperature: _____		Motor protection: CONTACT
NPSH required: ft		Thermal protection: internal
Viscosity: _____		
Specific Gravity: 1.000		

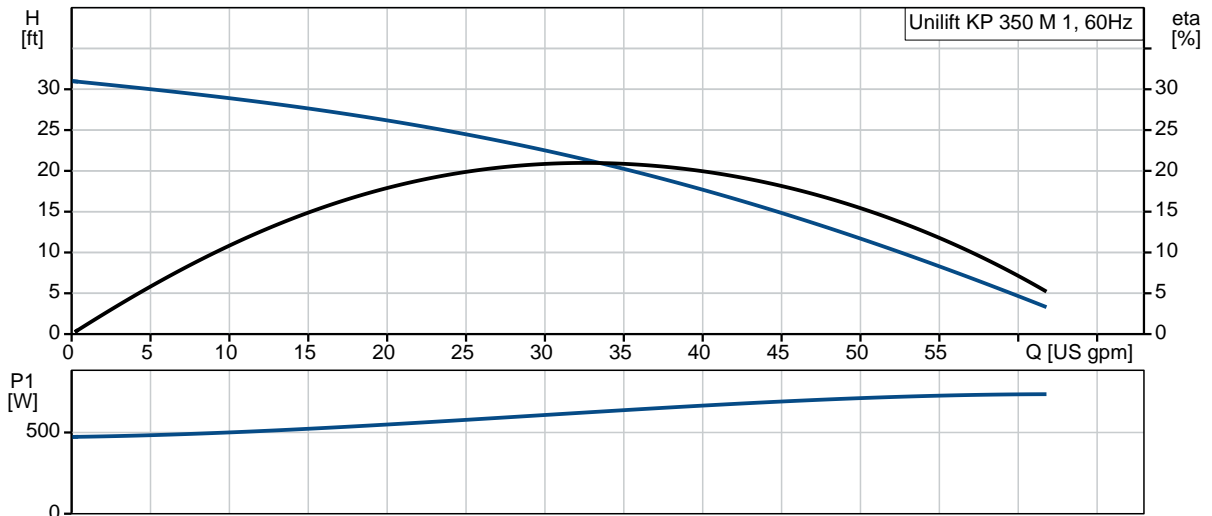

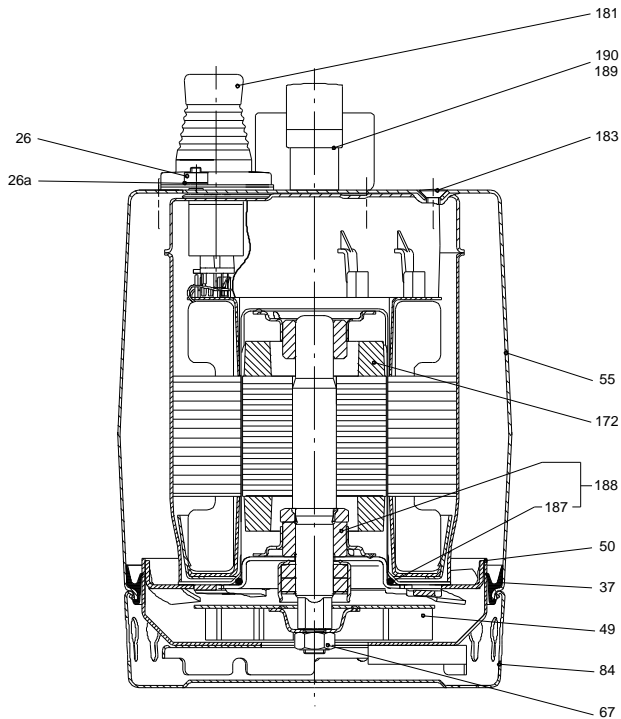
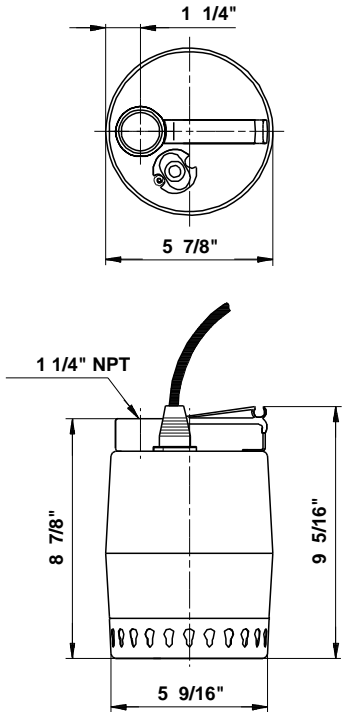

Materials:

- Pump housing: Stainless steel
DIN W.-Nr. 1.4301
AISI 304
- Impeller: Stainless steel
DIN W.-Nr. 1.4301
AISI 304



Company name:
Created by:
Phone:

Date: 3/23/2020

Count	Description
1	<p>Unilift KP 350 M 1</p>  <p>Product photo could vary from the actual product</p> <p>Product No.: 013DC201 Submersible drainage pump</p> <p>Vertical single-stage stainless steel submersible pump with vertical discharge port and integrated submersible 1-phase canned motor in insulation class F with thermal overload protection.</p> <p>The pump is fitted with a suction strainer, a carrying handle and is supplied with a 25 ft mains cable.</p> <p>The impeller is a semi-open impeller for 3/8" free passage suitable for pumping groundwater, surface water, rain water and similar liquids.</p> <p>The pump has a double shaft seal consisting of two lip seals with grease in-between.</p> <p>The pump has an outer casing ensuring continuous cooling of the motor by the pumped liquid. The rotor shaft operates in two maintenance-free carbon bearings cooled by the pumped liquid.</p> <p>The motor is filled with a non-toxic motor liquid.</p> <p>Liquid: Pumped liquid: any viscous fluid Liquid temperature range: 32 .. 113 °F Density: 62.29 lb/ft³</p> <p>Technical: Type of impeller: Semi-open Maximum particle size: 3/8 in Approvals on nameplate: UL Listed, CSA</p> <p>Materials: Pump housing: Stainless steel DIN W.-Nr. 1.4301 AISI 304</p>



Company name:

Created by:

Phone:

Date:

3/23/2020

Count	Description
	Impeller: Stainless steel DIN W.-Nr. 1.4301 AISI 304
	Installation:
	Pump outlet: 1 1/4" NPT
	Maximum installation depth: 24.9 ft
	Electrical data:
	Power input - P1: 850 W
	Main frequency: 60 Hz
	Rated voltage: 1 x 115 V
	Rated current: 7.5 A
	Starting current: 21.4 A
	Capacitor size - run: 20 µF/250 V
	Enclosure class (IEC 34-5): IP68
	Insulation class (IEC 85): F
	Length of cable: 25 ft
	Type of cable plug: US
	Others:
	Shipping volume: 0.44 ft ³
	Country of origin: HU
	Custom tariff no.: 8413.70.2004



Company name:
Created by:
Phone:

Date: 3/23/2020

013DC201 Unilift KP 350 M 1 60 Hz

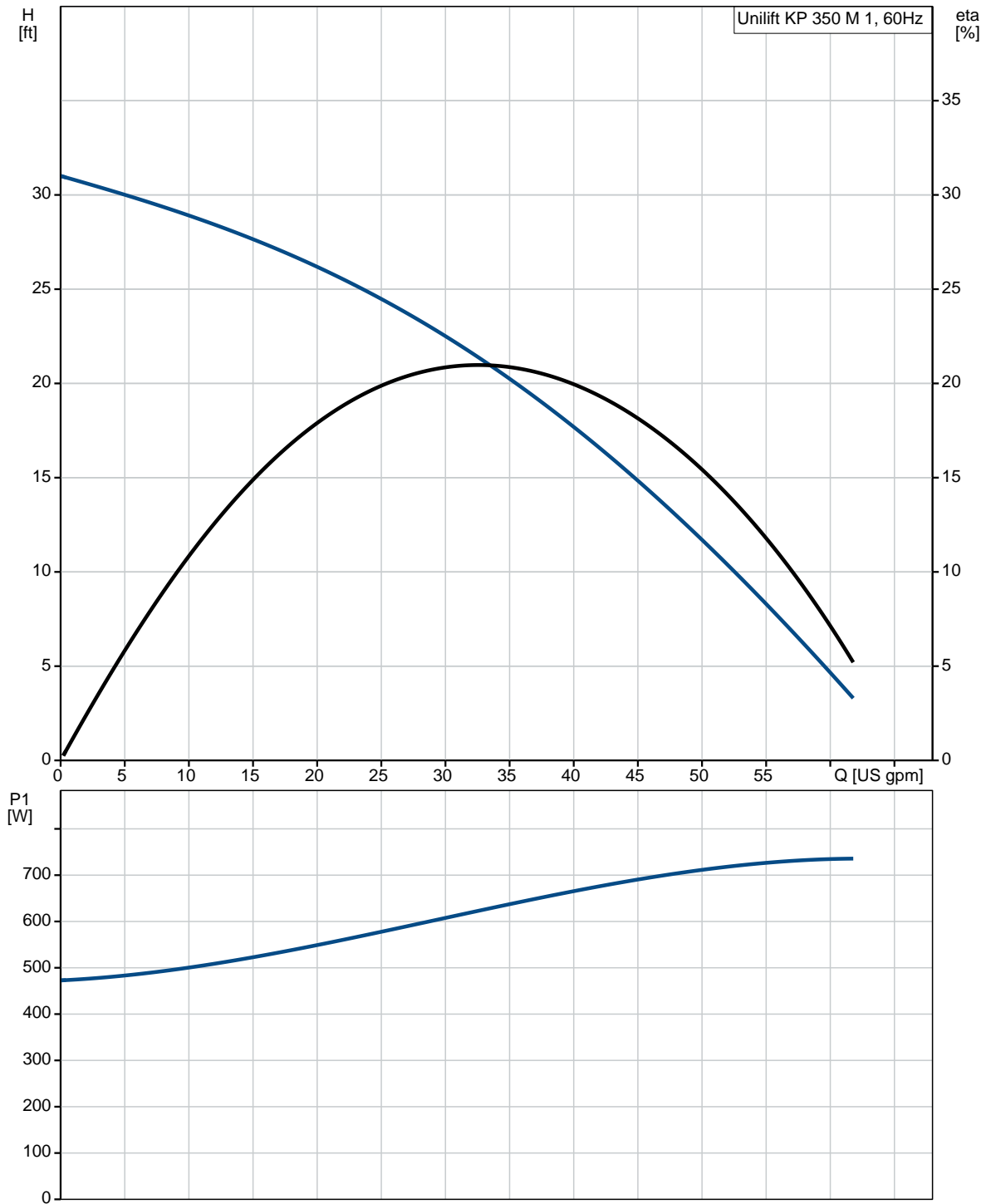



Company name:
Created by:
Phone:

Date: 3/23/2020

Description	Value
General information:	
Product name:	Unilift KP 350 M 1
Product No.:	013DC201
EAN:	5700392956057
	5700392956057
Technical:	
Max flow:	61.6 US gpm
Head max:	31.17 ft
Type of impeller:	Semi-open
Maximum particle size:	3/8 in
Approvals on nameplate:	UL Listed, CSA
Materials:	
Pump housing:	Stainless steel DIN W.-Nr. 1.4301 AISI 304
Impeller:	Stainless steel DIN W.-Nr. 1.4301 AISI 304
Installation:	
Pump outlet:	1 1/4" NPT
Maximum installation depth:	24.9 ft
Inst dry/wet:	D/S
Installation:	horizontal or vertical
Liquid:	
Pumped liquid:	any viscous fluid
Liquid temperature range:	32 .. 113 °F
Density:	62.29 lb/ft ³
Electrical data:	
Power input - P1:	850 W
Main frequency:	60 Hz
Rated voltage:	1 x 115 V
Rated current:	7.5 A
Starting current:	21.4 A
Capacitor size - run:	20 µF/250 V
Enclosure class (IEC 34-5):	IP68
Insulation class (IEC 85):	F
Motor protection:	CONTACT
Thermal protec:	internal
Length of cable:	25 ft
Type of cable plug:	US
Others:	
Shipping volume:	0.44 ft ³
Sales region:	Namreg
Country of origin:	HU
Custom tariff no.:	8413.70.2004

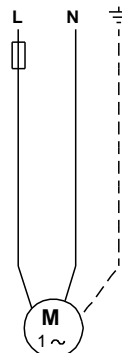
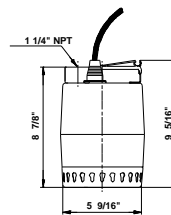
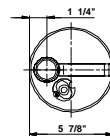
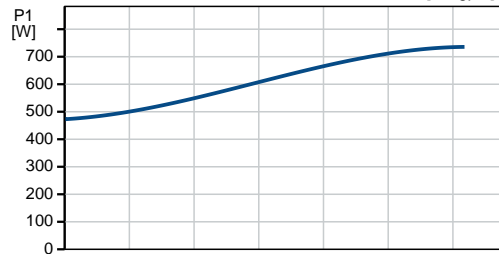
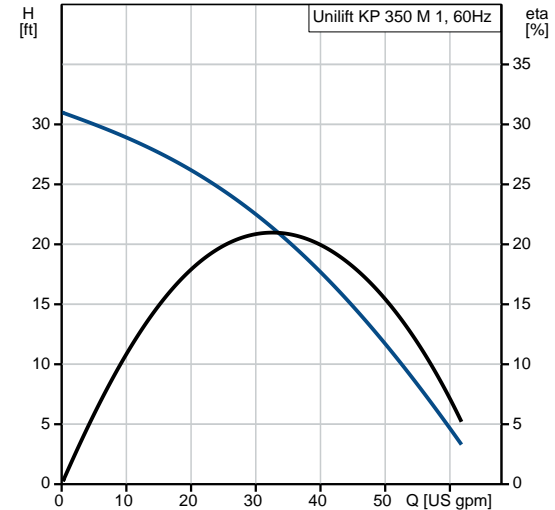



Company name:
Created by:
Phone:

Date: 3/23/2020

013DC201 Unilift KP 350 M 1 60 Hz

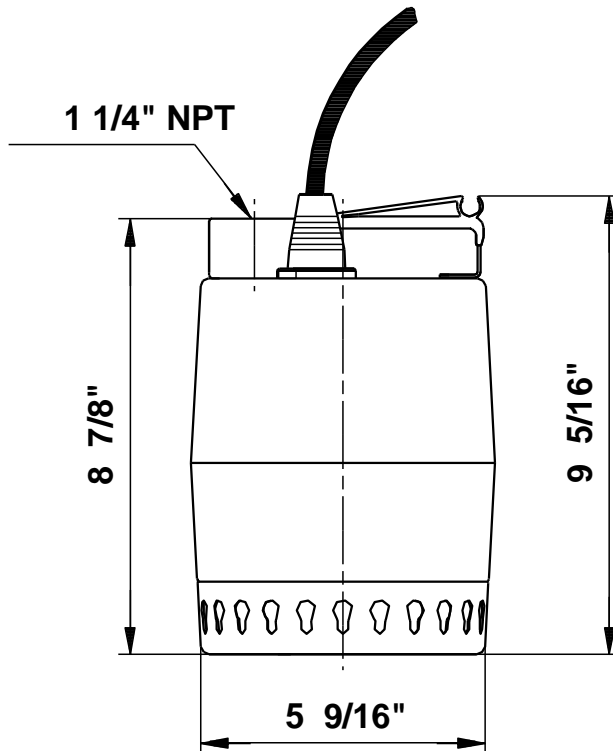
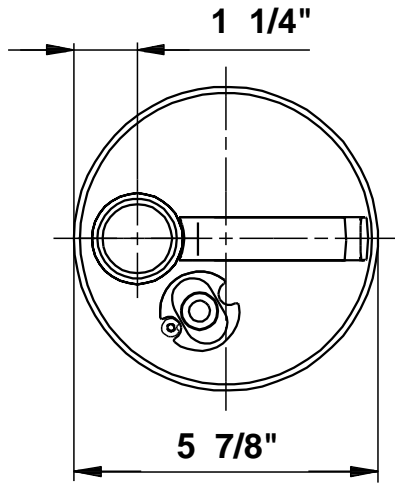

Note! All units are in [in] unless otherwise stated.
Disclaimer: This simplified dimensional drawing does not show all details.

013DC201 Unilift KP 350 M 1 60 Hz

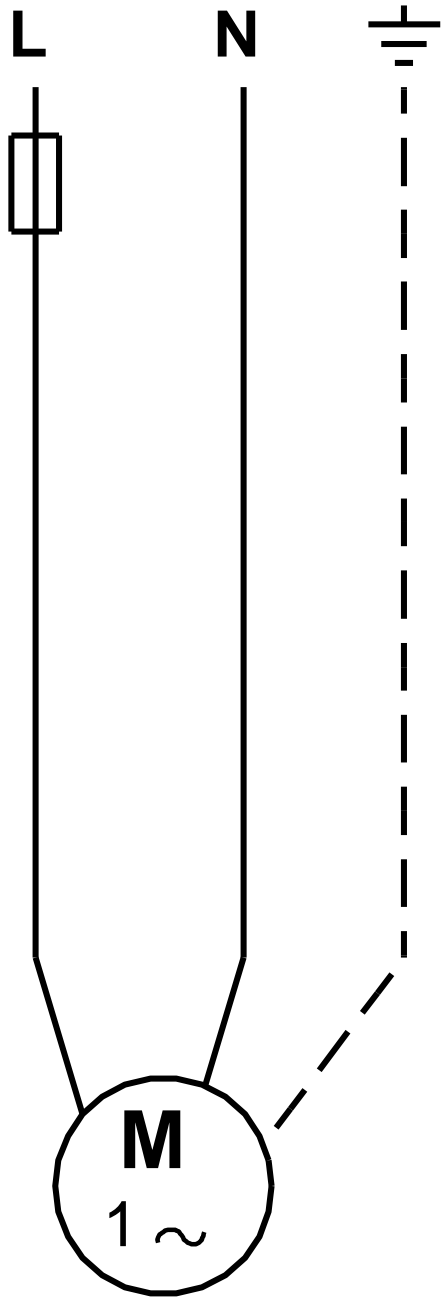

All units are [in] unless otherwise presented.