

Customer	Date	20.03.2020
Contact	Project	
Phone number	Project no.	
Email		

46SV20GL4F60N

Operating data

Pump type	Multi-Stage Pumps	Fluid	Water
No. of pumps / Reserve	1 / 0	Operating temperature t A	°F 39.2
Nominal flow	US g.p.m. 0	pH-value at t A	7
Nominal head	ft 0	Density at t A	lb/ft ³ 62.4
Static head	ft 0	Kin. viscosity at t A	ft ² /s 1.689E-5
Inlet pressure	psi 0	Vapor pressure at t A	psi 14.5
Environmental temperature	°F 68	Solids	0
Available system NPSH	ft 0	Altitude	ft 0

Pump data

Make	Goulds Water Technology	Nominal	US g.p.m. ()
Speed	rpm 3500	Flow	Max- US g.p.m. 317
No. of stages	1		Min- US g.p.m.
Max. working pressure	psi 105.5		Nominal ft
Head H(Q=0)	ft 240	Head	at Qmax ft 141.6
Weight	lb 438		at Qmin ft 243.4
Efficiency	%	Shaft power	hp ()
NPSH 3%	ft	Max. shaft power	hp 17.4

Shaft Seal

Single Seal	Xylem
Mechanical Seals	
1 - Rotating Face	Carbon
2 - Stationary Face	Silicon Carbide Graphite Filled
3 - Elastomers	Viton
4 - Spring	316SS
5 - Metal Components	316SS

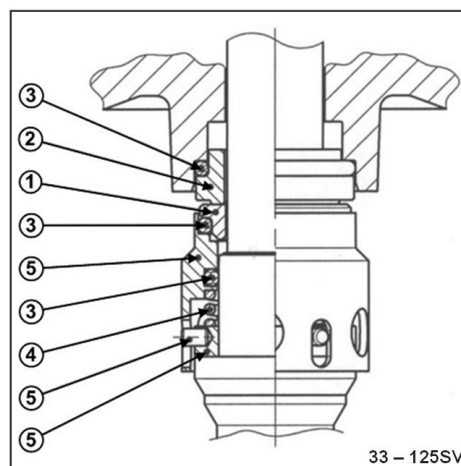

Motor data

Manufacturer	Baldor	Electric voltage	460 V	Speed	3500 rpm	Insulation class	F
Specific design	3ph TPE			Frame size	256TC	Colour	RAL 5010
Type	208-230/460V 256TC (V14A32E5BK2S)			Degree of protection	TEPE		
Rated power	20 hp	Electric current	23 A				

Remarks:

Customer	Date 20.03.2020
Contact	Project
Phone number	Project no.
Email	

46SV20GL4F60N

Pump Materials

1 - O-Ring, Piston Seal	Viton (std) EPDM (opt)
2 - O-Ring, Mechanical Seal Sleeve	Viton (std) EPDM (opt)
3 - O-Ring, Seal housing	Viton (std) EPDM (opt)
4 - O-Ring, Sleeve	Viton (std) EPDM (opt)
5 - Mechanical Seal	Refer Mechanical Seals
5A - Cartridge Seal	Refer Mechanical Seals
6 - Screw, Guard	Stainless Steel (A193-304)
7 - Screw, Piston Holding Disc	Stainless Steel (A193-316)
8 - Screw, Coupling	Zinc Plated Steel (B633)
9 - Screw, MA and Seal Housing	Zinc Plated Steel (B633)
10 - Screw, Impeller	Stainless Steel (A193-316)
11 - Washer, Coupling	Carbon Steel (A108)
12 - Washer, Impeller	Stainless Steel (A193-316)
13 - Pin, Coupling	Carbon Steel (A108)
14 - Plug, with Piston	Stainless Steel (A193-316)
15 - Plug, without Piston	Stainless Steel (A193-316)
16 - Plug, Fill	Stainless Steel/O-Ring (A193-316)
17 - Plug, Vent	Stainless Steel/O-Ring (A193-316)
18 - Plug, Drain	Stainless Steel/O-Ring (A193-316)
19 - Pump Head	Cast Iron (A48 Class 35)
20 - Impeller, Full Diameter	Stainless Steel (A193-316L)
21 - Impeller, Reduced Diameter	Stainless Steel (A193-316L)
22 - Lower Bearing Assembly	SS/Cast Iron (A193-316L/A48 Class 35)
23 - Piston	Duplex SS (A182-F51)
24 - Diffuser, Final	Stainless Steel (A193-316L)
25 - Diffuser with Carbon Bushing	Stainless Steel (A193-316L)
26 - Diffuser with Tungsten Bushing	Stainless Steel (A193-316L)
27 - Outer Sleeve, 25 Bar	Stainless Steel (A193-316L)
27A - Outer Sleeve, 40 Bar	Stainless Steel (A193-316L)
28 - Holding Disc, Piston Seal	Stainless Steel (A193-316L)
29 - Seal Housing	Cast Iron (A48 Class 35)
30 - Spacer, Impeller Final	Stainless Steel (A193-316)
31 - Spacer, Shaft Bushing	Stainless Steel (A193-316)
32 - Spacer, Impeller	Stainless Steel (A193-316)
33 - Spacer, Impeller Lower (66-92SV)	Stainless Steel (A193-316)
34 - Bushing, Non-Piston	Stainless Steel (A193-316)
35 - Tungsten Carbide Bushing	Tungsten carbide
36 - Coupling Guard	Stainless Steel (A193-304)
37 - Shaft	Duplex SS (A182-F51)
38 - Mechanical Seal Shaft Sleeve	Stainless Steel (A193-316)
39 - Wear Ring, Impeller	PPS Glass Filled
40 - Piston Seal	Impregnated Carbon
41 - Stop Ring, Impeller	Stainless Steel (A193-316)
42 - Pump Body	Cast Iron (A48 Class 35)
43 - Motor Adapter Plate	Cast Iron (A48 Class 25)

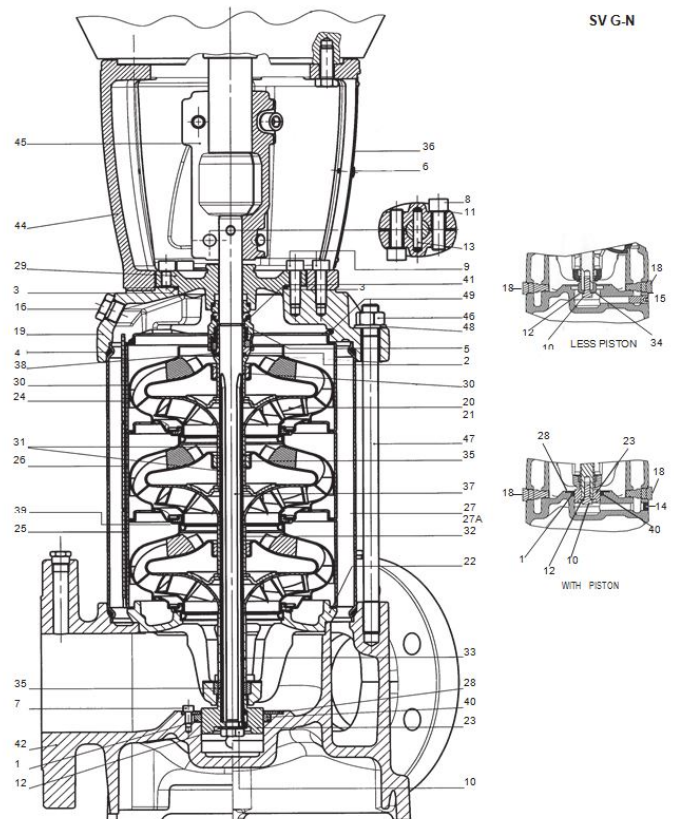

Remarks:

Customer	Date	20.03.2020
Contact	Project	
Phone number	Project no.	
Email		

46SV20GL4F60N

Hydraulic Data

Operating Data Specification		Hydraulic data (duty point)		Impeller design	
Flow	0 US g.p.m.	Flow		Impeller R	"
Head	0 ft	Head		Frequency	60 Hz
Static head	0 ft			Speed	3500 rpm

Power data referred to:
 Water [100%] ; 39.2°F; 62.4lb/ft³; 1.69E-5ft²/s
 Performance according to ISO 9906 - Annex A

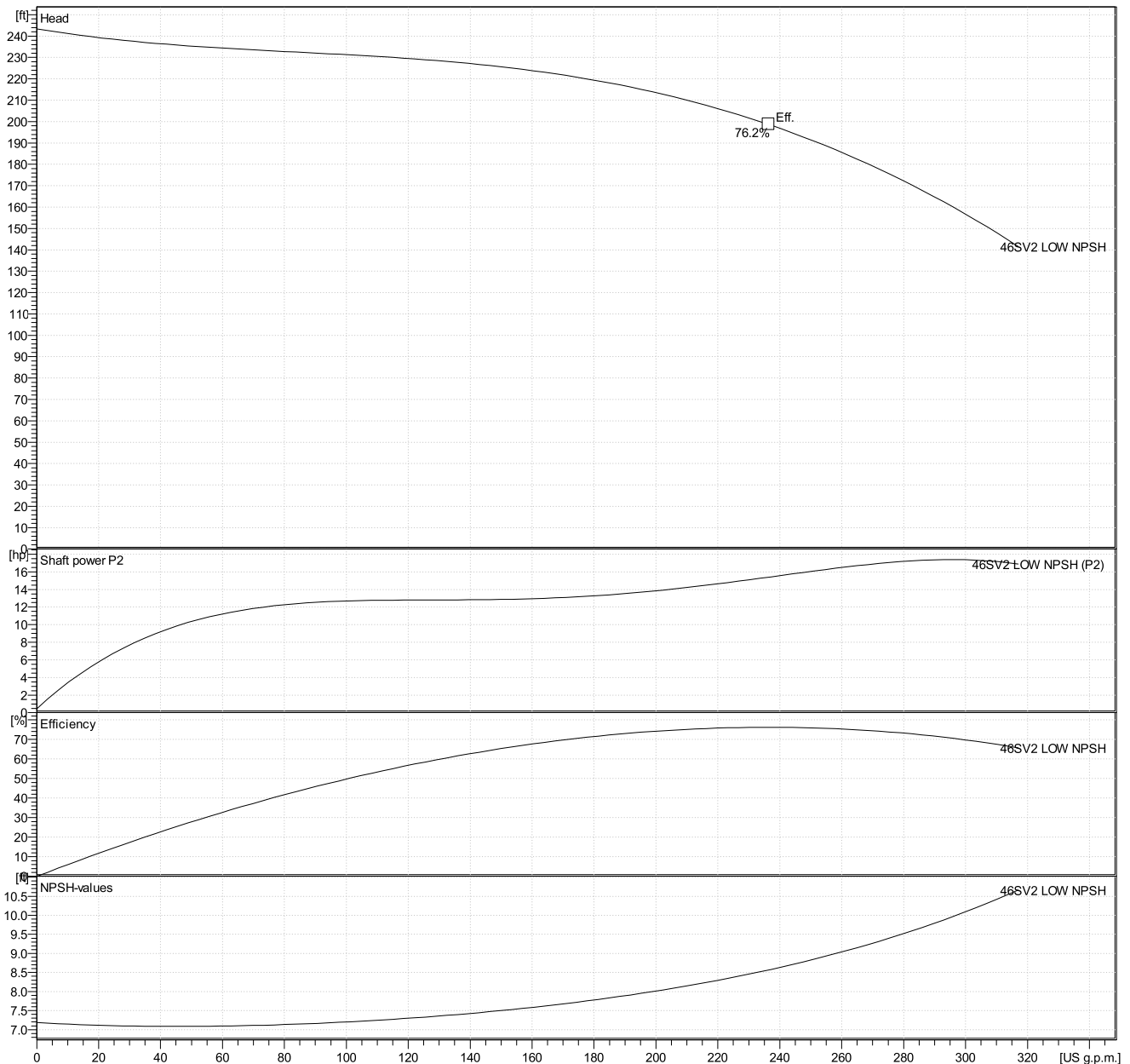

Customer	Date	20.03.2020
Contact	Project	
Phone number	Project no.	
Email		

46SV20GL4F60N

Drawing

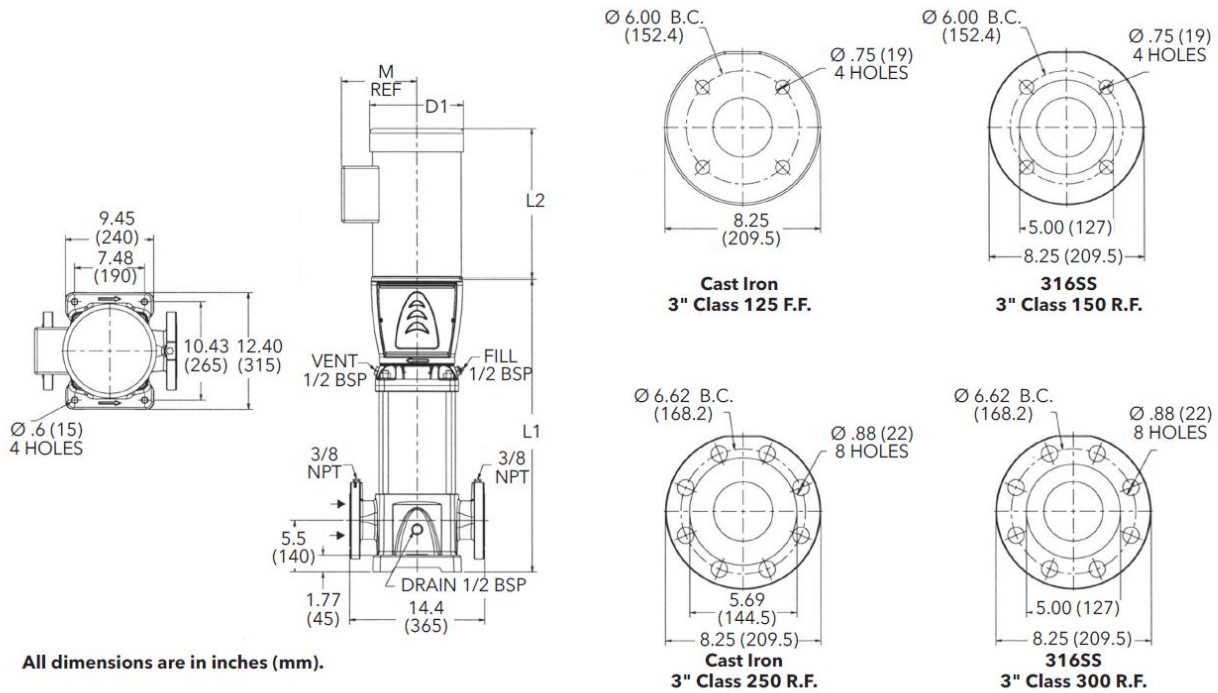

Dimensions inch

D1 max	13 ¹ / ₄					Weight 438 lb
D2	9 ⁷ / ₁₆					
L1	25 ⁷ / ₁₆					
L2	19 ¹³ / ₁₆					
M.Ref	9 ¹ / ₂					
NEMA Frame	256TC					