

Customer	Date	10.04.2020
Contact	Project	
Phone number	Project no.	
Email		

22SV5NK4F60

Operating data

Pump type	Multi-Stage Pumps	Fluid	Water
No. of pumps / Reserve	1 / 0	Operating temperature t A	°F 39.2
Nominal flow	US g.p.m. 0	pH-value at t A	7
Nominal head	ft 0	Density at t A	lb/ft ³ 62.4
Static head	ft 0	Kin. viscosity at t A	ft ² /s 1.689E-5
Inlet pressure	psi 0	Vapor pressure at t A	psi 14.5
Environmental temperature	°F 68	Solids	0
Available system NPSH	ft 0	Altitude	ft 0

Pump data

Make	Goulds Water Technology	Nominal	US g.p.m. ()
Speed	rpm 3500	Flow	Max- US g.p.m. 147.8
No. of stages	5		Min- US g.p.m.
Max. working pressure	psi 151.5	Nominal	ft
Head H(Q=0)	ft 350	Head	at Qmax ft 176.6
Weight	lb 330		at Qmin ft 349.5
Efficiency	%	Shaft power	hp ()
NPSH 3%	ft	Max. shaft power	hp 12

Shaft Seal

Single Seal	Xylem
Mechanical Seals	
1 - Rotating Face	Carbon
2 - Stationary Face	Silicon Carbide Graphite Filled
3 - Elastomers	Viton
4 - Spring	316SS
5 - Metal Components	316SS

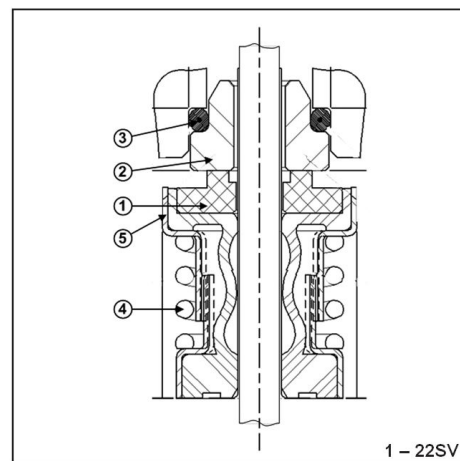

Motor data

Manufacturer	Baldor	Electric voltage	460 V	Speed	3500 rpm	Insulation class	F
Specific design	3ph TPE			Frame size	254TC	Colour	RAL 5010
Type	208-230/460V 254TC (V13A32E5BK2S)			Degree of protection	TEPE		
Rated power	15 hp	Electric current	17.2 A				

Remarks:

Customer	Date	10.04.2020
Contact	Project	
Phone number	Project no.	
Email		

22SV5NK4F60

Pump Materials

1 - Pump Body	Stainless Steel (AISI 316L)
2 - Impeller	Stainless Steel (AISI 316L)
3 - Diffuser	Stainless Steel (AISI 316L)
4 - Casing	Stainless Steel (AISI 316L)
5 - Shaft	Stainless Steel (AISI 316)
6 - Adapter	Cast Iron (ASTM Class 35/40B)
7 - Base	Aluminum (A384 .0-F)
8 - Coupling	Aluminum (A384 .0-F)
9 - Seal Plate	Stainless Steel (AISI 316L)
10 - Mechanical Seal	Refer Mechanical Seals
11 - Elastomers	Refer Mechanical Seals
12 - Coupling Guard	Stainless Steel (AISI 304)
13 - Shaft Sleeve and Bushing	Tungsten carbide
14 - Fill/Drain Plugs	Stainless Steel (AISI 316)
15 - Tie Rods	Carbon Steel / Zinc Plated (A29 Gr.1045)
16 - Wear Ring	PPS
17 - Seal Gland	Stainless Steel (AISI 316)

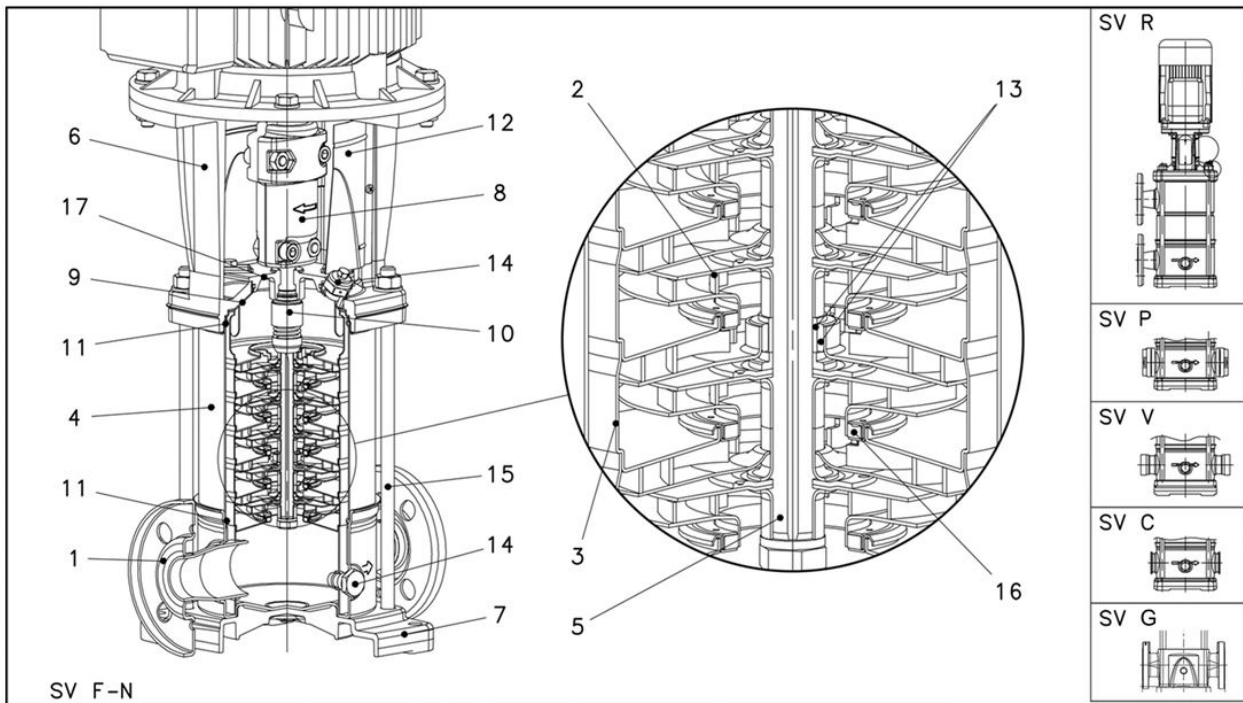

Remarks:

Customer	Date	10.04.2020
Contact	Project	
Phone number	Project no.	
Email		

22SV5NK4F60

Hydraulic Data

Operating Data Specification		Hydraulic data (duty point)		Impeller design	
Flow	0 US g.p.m.	Flow		Impeller R	"
Head	0 ft	Head		Frequency	60 Hz
Static head	0 ft			Speed	3500 rpm

Power data referred to:
 Water [100%] ; 39.2°F; 62.4lb/ft³; 1.69E-5ft²/s
 Performance according to ISO 9906 - Annex A

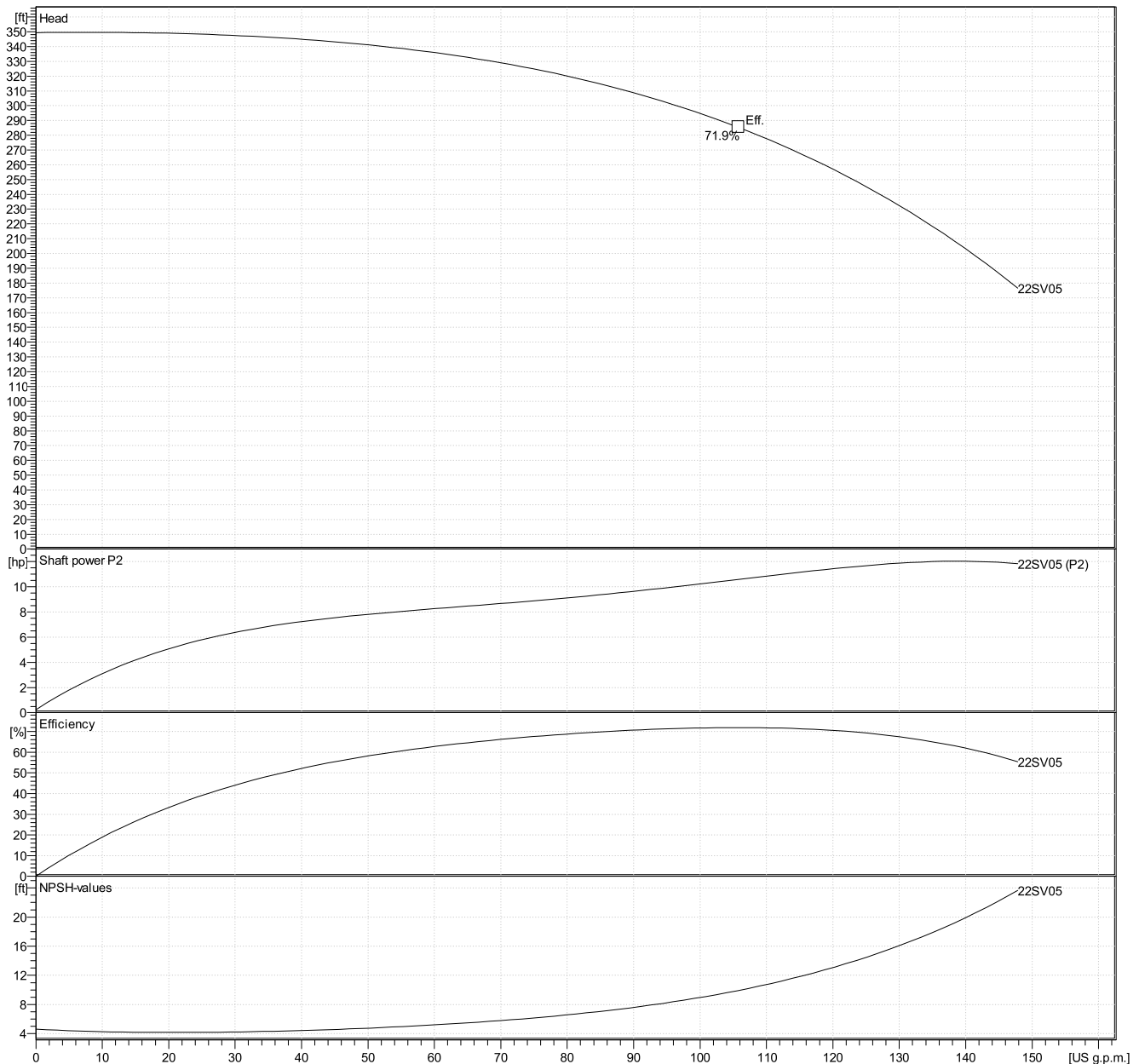

Customer	Date	10.04.2020
Contact	Project	
Phone number	Project no.	
Email		

22SV5NK4F60

Drawing

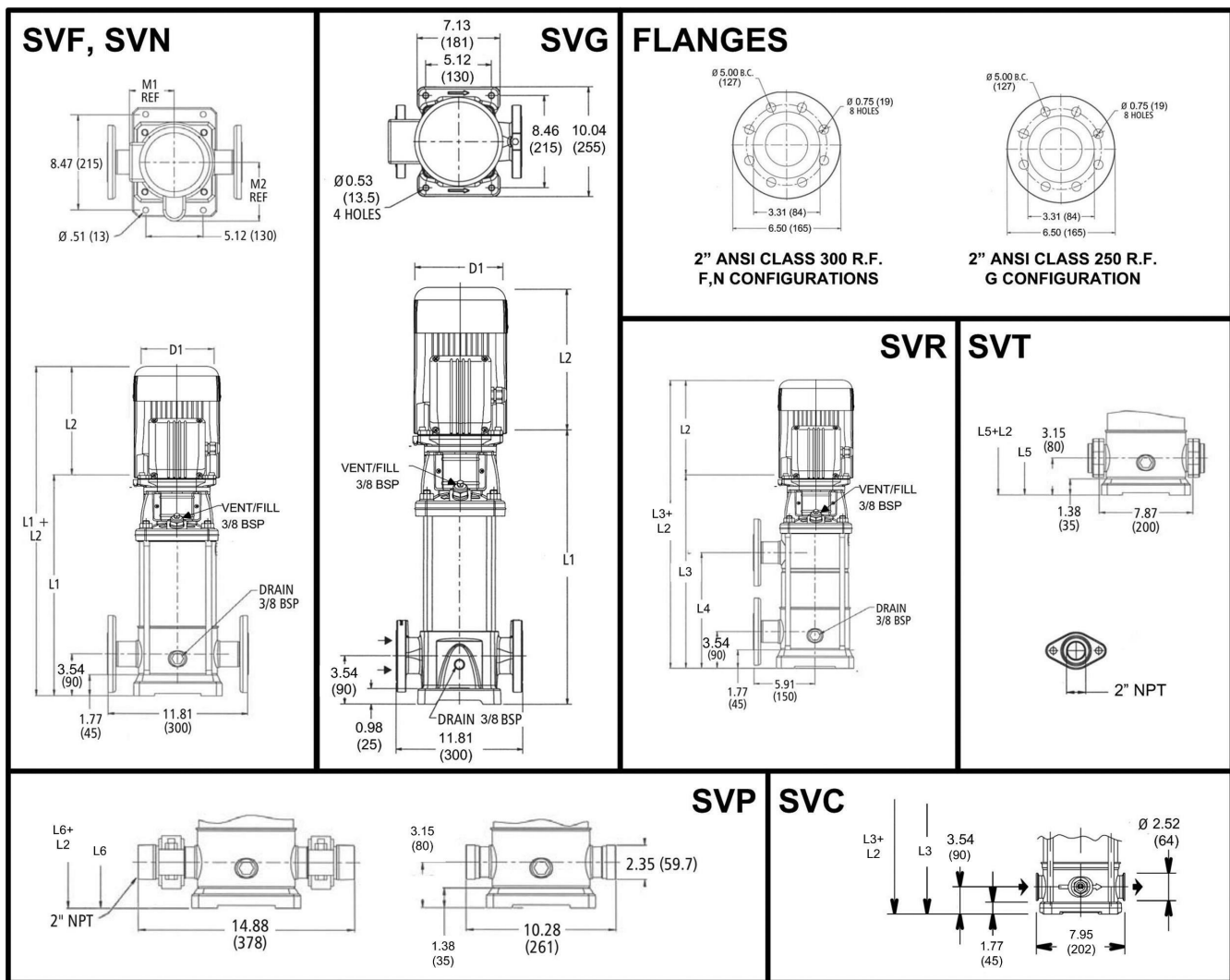

Dimensions inch

D1 max	13 ¹ / ₄	NEMA Frame	254TC			Weight	
D2	9 ⁷ / ₁₆					330	lb
L1	25 ⁷ / ₈						
L2	22 ¹ / ₁₆						
L3	25 ⁵ / ₈						
L4	13 ³ / ₄						
L5	25 ³ / ₁₆						
L6	25 ⁷ / ₁₆						
M.Ref	9 ¹ / ₂						