

CMBE, CMBE TWIN

Horizontal, multistage centrifugal pressure boosting pumps
60 Hz, North America



1. Product data	3
Introduction	3
Applications	3
Pumped liquids	3
Performance range	4
Identification	5
Installation	7
Selection guides for residential applications	8
2. CMBE TWIN	9
Applications	9
Product description	9
Motor	9
Features	9
Operating conditions	10
Electrical data	10
Approvals	10
Wetted parts	10
Dimensional drawings, CMBE TWIN	11
Control panel	12
Performance curves	13
3. CMBE	14
Applications	14
Product description	14
Motor	15
Operating conditions	15
Electrical data	15
Approvals	15
Wetted parts	15
Dimensional drawings, CMBE	16
Materials	17
Control panel	17
Performance curves	18
4. Product numbers	19
5. Grundfos Product Center	20

1. Product data

Introduction



Fig. 1 CMBE

TM07 2892 4318

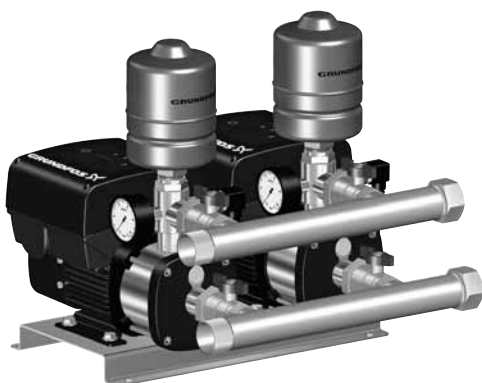

Fig. 2 CMBE TWIN

TM07 2893 4318

The compact Grundfos CMBE and CMBE TWIN ensure optimal water pressure for domestic and commercial applications, such as clean water and raw-water supply, pressure boosting, irrigation and dewatering.

Each pump is delivered complete with 5-way fittings, non-return valves, diaphragm tank, pressure sensor and pressure gauge.

- CMBE offers constant pressure and high comfort thanks to the variable-speed motor, noiseless operation and built-in protection against dry running, overload, over temperature and more. The CMBE consists of a Grundfos CME pump and a pressure control unit. The pressure control unit allows the pump to start and stop automatically according to demand.
- CMBE TWIN has two CMBE pumps that operate in parallel. The two pumps are mounted on a common base plate. Both pumps run when there is need for a higher flow to maintain a constant pressure.

Applications

The pumps are designed to cover a wide range of applications from domestic installations to small commercial applications. Typical applications:

- Pressure boosting for home and gardening
- water supply for agriculture and irrigation
- water supply from shallow wells
- a twin solution for larger applications, such as apartment buildings, hospitals, hotels and small industrial plants
- domestic fire suppression.

Pumped liquids

The pumps are suitable for pumping clean, thin, non-aggressive and non-explosive liquids without solid particles or fibers. Examples:

- Drinking or tap water
- rainwater and condensate
- groundwater
- river and lake water
- boiler feed water and district heating water
- chlorinated water
- softened water
- washing and cleaning.

The pumps must not be used for transfer of diesel oil or other oil-containing liquids. Sand and other impurities in the water can cause wear to the pump.

Performance range

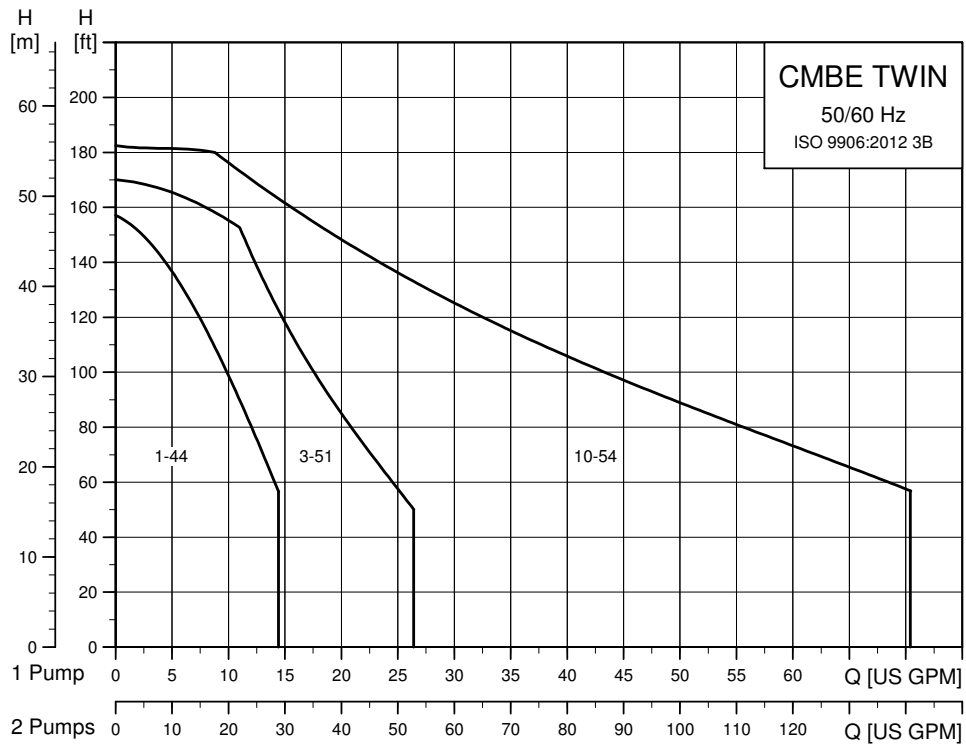

TM07 3869 0519

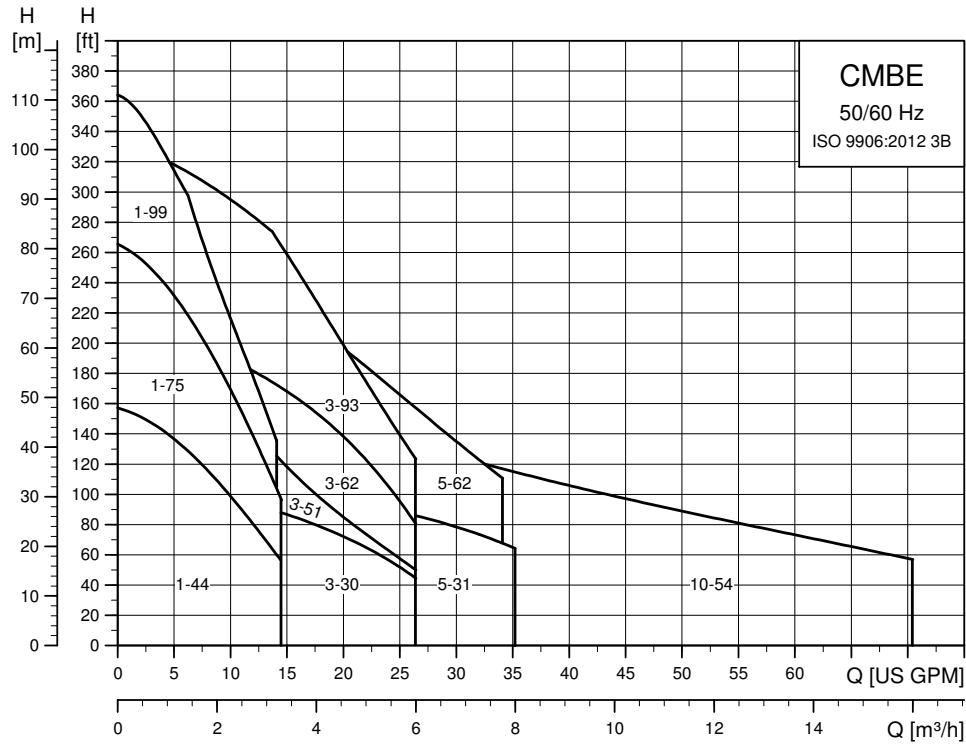

TM06 1420 0614

Identification

Nameplate, CMBE

Type	1	Q _{nom}	14	GPM
Model	2-3 YYWW	T _{amb,max}	15	°F
U	4	V	T _{liq,max}	16 °F
I 1/1	6	A	17	
f	7 Hz	P1	8	HP
P _{max}	9/10 MPa/PSI	IP	11	
H _{max}	12 PSI	H _{nom}	13	PSI
Made in USA		18		19

GRUNDFOS X

TM06 3510 0515

Fig. 3 Nameplate, CMBE

Pos.	Description
1	Combined product type and configuration
2	Code of model
3	Material number
4	Supply voltage
6	Full load Amps
7	Frequency
8	Power input (HP)
9	Max. system pressure (MPa)
10	Max. system pressure (psi)
11	IP Class
12	Maximum head (psi)
13	Nominal head (psi)
14	Nominal flow rate (gpm)
15	Max. ambient temp. (°F)
16	Max. liquid temp. (°F)
17	EFF
18	Combined approvals
19	Nameplate layout

Nameplate, CMBE TWIN

Type:	①		
Model:	②		
Serial No.:	③		
Mains supply:	④		
pMax:	⑤ PSI	Q Nom / Max:	⑪ GPM
Liq. temp.:	⑥ °F	H Nom / Max:	⑫ ft
Panel PN:	⑦		
Weight:	⑧ lb	QR	⑬
ASSEMBLED IN US		⑨	⑭
⑩ GRUNDFOS X		⑮	
<small>DK - 8850 - Bjerringbro - Denmark</small>			

TM07 2117 4218

Fig. 4 Nameplate, CMBE TWIN

Pos.	Description
1	Type designation
2	Model
3	Serial number
4	Supply voltage
5	Max. operating pressure [psi]
6	Liquid temperature [°F]
7	Panel part number
8	Weight in lb
9	Country of origin
10	Company logo
11	Nominal/max. flow rate [gpm]
12	Nominal/max. head [ft]
13	Approval mark
14	Approval mark
15	QR code (if applicable)

Type key

Example	CMBE	1	- 47	- I	- K	- A	- C	- D	- A
Type range CMBE TWIN: CMBE TWIN with cascade control and pump alternation CMBE: CMBE with integrated variable frequency drive									
Rated flow rate At 60 Hz [m ³ /h]									
Maximum head [m]									
Materials in contact with the pumped liquid									
A: Inlet and outlet parts									
Pump shaft									
Impellers/chambers									
Pressure manager									
Pressure tank									
5-way valve									
I: Sleeve									
Pump shaft									
Impellers/chambers									
Pressure manager									
Pressure tank									
5-way valve									
Supply voltage									
U: 1 x 200-240 V, 60 Hz ¹⁾									
X: 1 x 115 V, 60 Hz									
Motor: High-efficiency motor with variable frequency drive (IP55)									
Cable and plug									
B: 4.9 ft (1.5 m) cable with US plug ²⁾									
Controller									
D: Integrated variable frequency drive									
Thread									
E: NPT 1									
G: NPT 1 1/2									
H: NPT 2									

¹⁾ The new-generation MLE, currently 1/2 to 2 HP (0.37 to 2.2 kW).

²⁾ CMBE has 4.9 ft (1.5 m) cable with US plug. CMBE TWIN is for fuse box connection and has 15 ft (4.5 m) cable (no plug).

Note: The type key cannot be used for ordering as not all combinations are possible.

Installation

Mechanical installation

Placing the pump above ground is generally a convenient way of establishing a water or rainwater supply.

Place the pump as close as possible to the water supply to make the inlet pipe as short as possible.

If a hose is used as the inlet pipe, it must be non-collapsible. Fit a strainer to the inlet pipe to prevent solids from entering the pump.

The pump must be installed on a plane and solid surface, and fixed so that it cannot be displaced during startup and operation. The inlet direction must be horizontal.

The pump must be installed with easy access for inspection, maintenance and service.

The pump must be installed in a well-ventilated location. When installed outdoors, the pump must be provided with a suitable cover. The cover must be sufficiently large to ensure that the motor is not exposed to direct sunlight, rain or snow.

Inlet pipe

If the pump is to pump water from a well, borehole or similar, always fit a non-return valve on the inlet pipe of the pump.

The length of the inlet pipe of self-priming pumps must not exceed the length stated in fig. 5. The maximum length depends on the geodetic suction lift. As shown in the example below, if the suction lift is 8.2 ft (2.5 m), then the length of the inlet pipe must not exceed 82 ft (25 m).

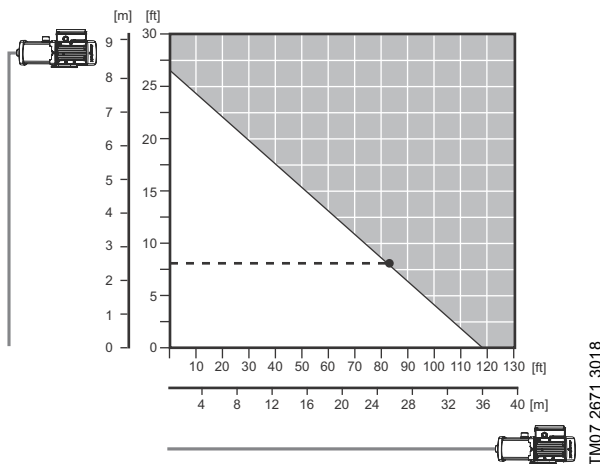

Fig. 5 Recommended maximum suction lift or maximum inlet pipe length (Y-axis)

Install the inlet pipe in such a way that bends, airlocks and any unnecessary restrictions to the flow are avoided. See fig. 6.

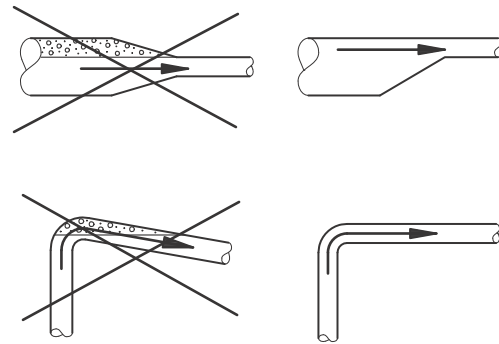

Fig. 6 Pipe recommendations

Long inlet pipes affect the performance of the pump. The diameter of the inlet pipe must not be smaller than that of the inlet port. When the inlet pipe is longer than 32 ft (10 m) or the suction lift is greater than 13 ft (4 m), the diameter of the inlet pipe must be larger than that of the inlet port.

The time from when the pump is started until it delivers water depends on the length of the inlet pipe and on the suction lift. Do not allow the pump to run for more than five minutes before it delivers water as the heat generated will damage the pump.

Operating conditions

The maximum time of operation against a closed outlet valve is limited by the liquid temperature which must not exceed 104 °F (+40 °C).

The maximum inlet pressure depends on the pump head at the actual duty point. The sum of the inlet pressure and the pump head must not exceed the maximum system pressure.

Electrical installation

The electrical connection and protection must be carried out in accordance with local regulations.

- The pump must be connected to an external main switch with a minimum contact gap of 0.1 in (3 mm) in all poles.
- Make sure that the pump is suitable for the power supply to which it is to be connected.
- The pump and pressure control unit must always be correctly grounded.
- Single-phase CMBE requires no external motor protection. The variable-speed motor incorporates thermal protection against slow overloading and blocking.

TM04 0438 0608

TM07 2671 3018

Selection guides for residential applications

The following instructions primarily target residential applications. This is a quick and easy guide to show you which product is ideal for your needs. Follow the charts and instructions, and you will be sure to get a perfect fit. Example:

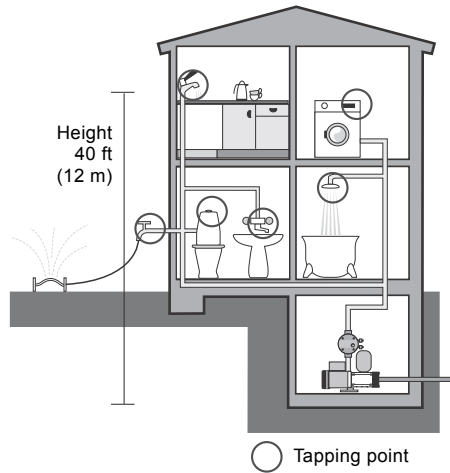

- A: Required comfort level**
- Adjustable constant pressure.
- B: Find the right booster**
- How many taps? 6.
 - How many floors? 3.
- Result: CMBE 1-75**

		Number of taps			
		1-5	6-10	11-20	21-50
Number of floors	4	CMBE 1-75	CMBE 1-75	CMBE 3-62	CMBE 3-93
	3	CMBE 1-44	CMBE 1-75	CMBE 3-62	CMBE 3-62
	2	CMBE 1-44	CMBE 1-44	CMBE 3-62	CMBE 3-62
	1	CMBE 1-44	CMBE 1-44	CMBE 3-30	CMBE 3-62

TM07 2742 3018

Fig. 7 Sizing and selection example

1 x 230 V supply power flow rate selection chart

PSI boost	0-15 gpm	0-25 gpm	0-35 gpm	0-45 gpm	0-55 gpm	0-65 gpm	0-70 gpm
20	CMBE 1-44	CMBE 3-30	CMBE 5-31	CMBE 10-54	CMBE 10-54	CMBE 10-54	CMBE 10-54
25	CMBE 1-44	CMBE 3-30*	CMBE 5-31	CMBE 10-54	CMBE 10-54	CMBE 10-54	CMBE 10-54
30	CMBE 1-75	CMBE 5-31	CMBE 5-31	CMBE 10-54	CMBE 10-54	CMBE 10-54	CMBE 10-54*
35	CMBE 1-75	CMBE 3-62	CMBE 5-31	CMBE 10-54	CMBE 10-54	CMBE 10-54*	-
40	CMBE 1-75	CMBE 3-62	CMBE 5-62	CMBE 10-54	CMBE 10-54*	-	-
45	CMBE 1-75	CMBE 3-62	CMBE 5-62	CMBE 10-54*	-	-	-
50	CMBE 1-99	CMBE 3-62	CMBE 5-62	CMBE 10-54*	-	-	-
55	CMBE 1-99	CMBE 3-93	CMBE 5-62	-	-	-	-
60	CMBE 1-99	CMBE 3-93	CMBE 5-62	-	-	-	-
65	CMBE 1-99	CMBE 5-62	-	-	-	-	-
70	CMBE 3-93	CMBE 5-62	-	-	-	-	-
75	CMBE 3-93	CMBE 5-62	-	-	-	-	-
80	CMBE 3-93	CMBE 5-62	-	-	-	-	-

* Indicates pump may be 5-10 % undersized on flow at desired pressure.

1 x 115 V supply power flow rate selection chart

PSI boost	0-10 gpm	0-15 gpm	0-20 gpm	0-25 gpm
20	CMBE 1-44	CMBE 1-44	CMBE 3-30	CMBE 3-30
25	CMBE 1-44	CMBE 1-44	CMBE 3-30	CMBE 3-30
30	CMBE 1-44	CMBE 1-44	CMBE 3-30	CMBE 3-51
35	CMBE 1-44	CMBE 1-75	CMBE 3-51	CMBE 3-51*
40	CMBE 1-44	CMBE 3-51	CMBE 3-51*	CMBE 3-51*
45	CMBE 1-44	CMBE 3-51	CMBE 3-51*	-
50	CMBE 1-44	CMBE 3-51	-	-
55	CMBE 1-75	CMBE 3-51*	-	-
60	CMBE 1-75	CMBE 3-51*	-	-
65	CMBE 1-75*	-	-	-
70	CMBE 1-75*	-	-	-
75	CMBE 1-75*	-	-	-
80	CMBE 1-75*	-	-	-

* Indicates pump may be 5-10 % undersized on flow at desired pressure.

2. CMBE TWIN

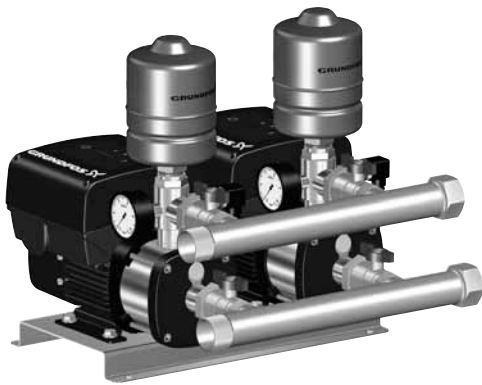

TM07 2893 4318

Fig. 8 CMBE TWIN

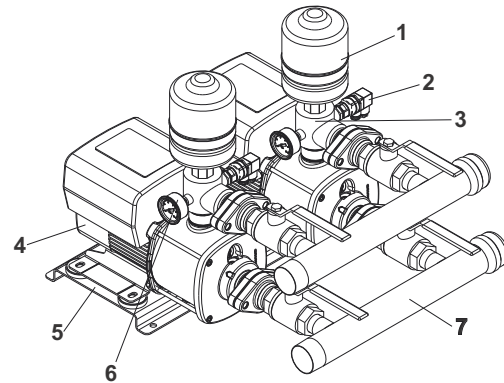

TM07 1942 3018

Fig. 9 CMBE TWIN components

Applications

The compact Grundfos CMBE TWIN is suitable for clean water supply and pressure boosting in domestic and commercial applications. The CMBE TWIN keeps a constant pressure in the pipe system and is mainly used in places such as:

- two-family houses
- cluster homes
- apartment buildings
- schools
- small hotels
- small office buildings
- small industrial plants and businesses
- hospitals
- agriculture and irrigation.

Product description

The CMBE TWIN system consists of two CMBE pumps connected in parallel and mounted on a common base plate. Each CMBE pump includes a Grundfos integrated variable frequency drive (VFD). Each CMBE pump is delivered complete with 5-way fittings, non-return valves, diaphragm tank, pressure sensor and pressure gauge.

Pos.	Description
1	Diaphragm tank
2	Pressure sensor
3	5-way fitting with integrated non-return valve
4	CME pump
5	Base plate
6	Pressure gauge
7	Inlet/outlet pipes with ball valves and unions

Motor

No external motor protection is required. The MLE motor incorporates thermal protection against slow overloading and blocking.

Features

- Constant pressure via integrated speed control
- cascade control and pump alternation
- dry-running protection
- compact
- robust, stainless steel design
- easy installation
- low energy consumption
- noise level below 58 dBA and even lower at controlled speed.

Constant pressure

The integrated speed controller keeps a constant pressure in the pipe system. A pressure sensor monitors changes in the water consumption and signals to the speed controller to adjust the motor speed up or down.

Cascade control

Cascade control ensures that the performance of the booster system is automatically adapted to the consumption by switching pumps on or off and by changing the speed of the pumps in operation. The system runs as energy-efficiently as possible with a constant pressure and only with the number of pumps required.

Pump alternation

Pump alternation ensures that the operating hours are distributed evenly on the pumps over time. CMBE TWIN automatically alternates the pumps and will start the available pump with the lowest number of running hours since the last time the power was switched off.

Dry-running protection

Dry-running protection is very important as dry running may damage the bearings and shaft seals. Lack of inlet pressure or water shortage is indicated by the motor speed. When dry running is detected, the CMBE will stop and go into alarm mode.

Easy installation

CMBE TWIN is easy to install. When the CMBE TWIN has been connected to the pipes and to the power supply, the system is operational.

Operating conditions

System pressure	Max. 145 psi (10 bar) (1 MPa).
Suction lift	Max. 3.28 ft (1 m), including suction-pipe pressure loss at a liquid temperature of 68 °F (+20 °C).
Liquid temperature	32-140 °F (0-60 °C).
Ambient temperature	Max. 131 °F (+55 °C). Min. -4 °F/ (-20 °C).
Relative humidity	Max. 95 %.
Enclosure class	IP55.
Insulation class	F.
Sound pressure level	≤ 58 dB(A)
Supply voltage	1 x 115 V, 60 Hz, 1 x 200-240 V, 60 Hz.
Start/stop frequency	Max. 100 per hour.
Cut-in pressure	7.25 psi (0.5 bar) below setpoint.

Electrical data

CMBE TWIN	1-44	3-51	10-54	Plug type
Supply voltage	1 x 115 V 60 Hz	1 x 115 V 60 Hz	1 x 200-240 V 60 Hz	
Max. current for both pumps combined - high value [A]	16	16	18.2	
Max. current for both pumps combined - low value [A]	16	16	18.2	See below*
Max. power for both pumps combined power (P1) [W]	1265.2	1749	3404	

* CMBE TWIN is for fuse box connection and has 15 ft (4.5 m) cable (no plug).

Approvals

Drinking water certifications:



UL Electrical:

1 x 230 V CMBE models: UL Listed Packaged Pumping System

Wetted parts



The table below specifies the parts of the pump that are in contact with the pumped liquid.

Designation	Material	Technical description
Pump sleeve	Stainless steel	AISI 304 / EN 1.4301
Impeller	Stainless steel	AISI 304 / EN 1.4301
Diffuser	Technopolymer	PP 20 % Talc
Ejector	Technopolymer	PPE/PS 20 % GF
Nozzle	Stainless steel	AISI 304 / EN 1.4301
Shaft	Stainless steel	AISI 304 / EN 1.4301
Shaft seal	Carbon with resin/ceramic	CVBP
Filling plug	Technopolymer	PES 30 % GF
Drain plug	Technopolymer	PES 30 % GF

Dimensional drawings, CMBE TWIN

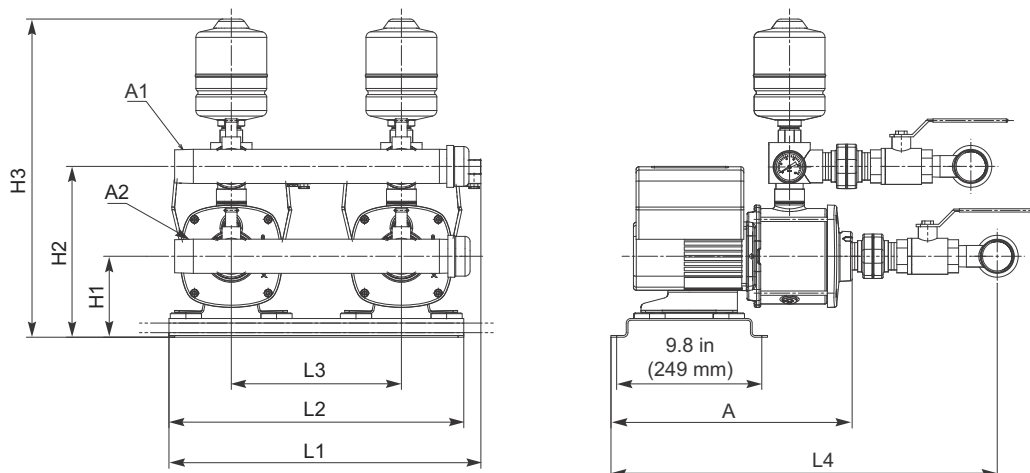

TM07 2634 4218

Pump type	H3 [in (mm)]	H2 [in (mm)]	H1 [in (mm)]	L1 [in (mm)]	L2 [in (mm)]	L3 [in (mm)]	L4 [in (mm)]	A [in (mm)]	A1 [in]	A2 [in]	Net wt [lb (kg)]
CMBE TWIN 1-44	19.6 (498)	9.25 (235)	4.25 (108)	19.6 (498)	9.85 (250)	18.51 (470)	20.35 (517)	12.3 (313)	1 1/2 NPT	1 1/2 NPT	120 (54.5)
CMBE TWIN 3-51	19.6 (498)	9.25 (235)	4.25 (108)	19.6 (498)	9.85 (250)	18.51 (470)	20.35 (517)	12.3 (313)	1 1/2 NPT	1 1/2 NPT	123 (55.8)
CMBE TWIN 10-54	22.0 (559)	11.0 (280)	4.61 (117.1)	21.1 (536)	11.82 (300)	20.48 (520)	26.81 (681)	16.3 (414)	2 NPT	2 NPT	180 (81.7)

Control panel

The control panel on the pump terminal box makes it possible to change the setpoint settings manually. The operating condition of the pump is indicated by the Grundfos Eye on the control panel.

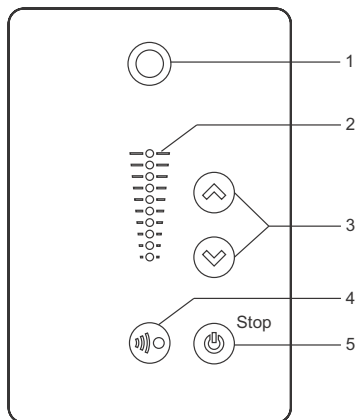

TM05 48/48 3512

Fig. 10 Control panel

Pos.	Symbol	Description
1		Grundfos Eye Shows the operating status of the pump.
2	-	Light fields for indication of setpoint.
3		Changes the setpoint.
4		Enables radio communication with the Grundfos GO Remote and other products of the same type.
5		Makes the pump ready for operation/ starts and stops the pump. Start: If the button is pressed when the pump is stopped, the pump will only start if no other functions with higher priority have been enabled. Stop: If the button is pressed when the pump is running, the pump will always be stopped. When the pump is stopped via this button, the "Stop" text next to the button will illuminate.

Performance curves

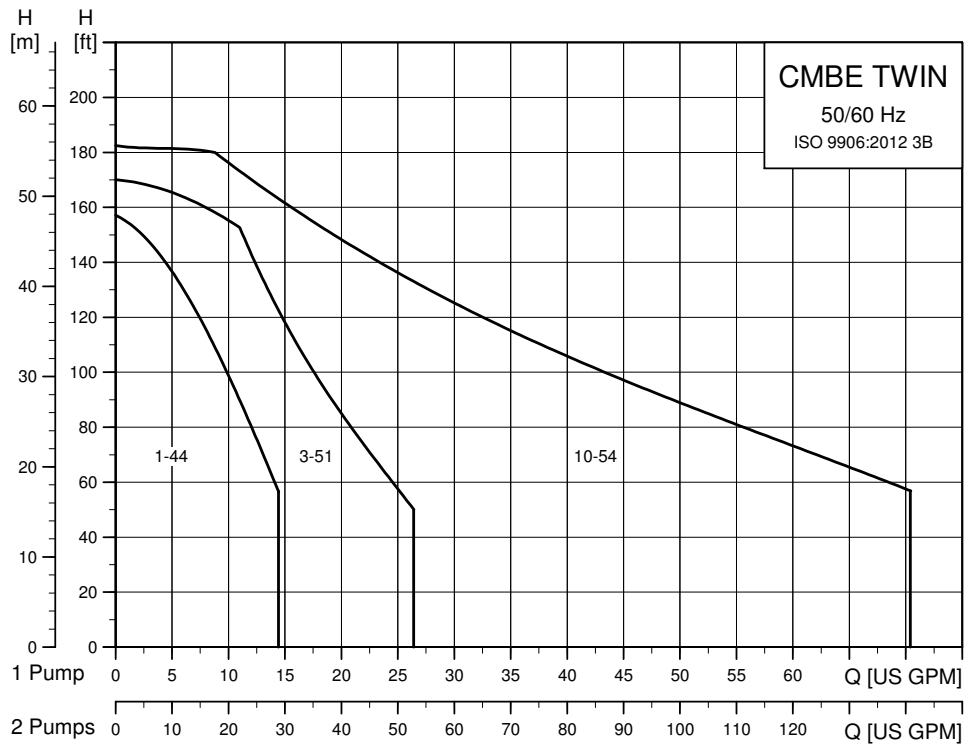

TM07 3869 0519

3. CMBE

CMBE



Fig. 11 CMBE

Applications

The compact Grundfos CMBE is suitable for clean water supply and pressure boosting in domestic and light commercial applications.

The CMBE keeps a constant pressure in the pipe system and is mainly used in places such as:

Application	CMBE 1	CMBE 3	CMBE 5	CMBE 10
Single-family houses	•	•	○	○
Two-family houses	○	•	•	•
Cluster homes		•	•	•
Apartments		•	•	•
Schools		•	•	•
Small hotels/guest houses		•	•	•
Small office buildings		•	•	•
Agriculture		○	•	•
Irrigation		○	•	•

- Recommended
- Applicable.

TM07 2892 4318

Product description

The CMBE consists of these components:

- CMBE pump with integrated frequency drive
- 5-way fitting with non-return valve
- diaphragm tank
- pressure gauge
- pressure sensor
- inlet pressure switch (optional).

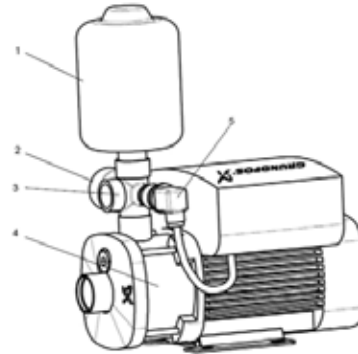

Fig. 12 CMBE components

Pos.	Description
1	Diaphragm tank
2	Pressure gauge
3	Five-way fitting with integrated non-return valve
4	CMBE pump
5	Pressure sensor

TM06 0794 0214

Motor

No external motor protection is required. The MLE motor incorporates thermal protection against slow overloading and blocking.

Features

- Constant pressure via integrated speed control
- dry-running protection
- compact
- robust, stainless steel design
- easy installation
- low energy consumption
- noise level below 55 dBA and even lower at controlled speed.

Constant pressure

The integrated speed controller keeps a constant pressure in the pipe system. A pressure sensor monitors changes in the water consumption and signals to the speed controller to adjust the motor speed up or down.

Dry-running protection

Dry-running protection is very important as dry running may damage the bearings and shaft seals. The inlet pressure of the system or the water level in a possible tank on the inlet side is monitored. Lack of inlet pressure or water shortage is indicated by the motor speed. When dry running is detected, the CMBE will stop and go into alarm mode.

Easy installation

The CMBE is easy to install. When the CMBE has been connected to the pipes and to the power supply, the system is operational.

Operating conditions

System pressure	Max. 145 psi (10 bar)(1 MPa).
Suction lift	Max. 3.28 ft (1 m), including suction-pipe pressure loss at a liquid temperature of 68 °F (+20 °C).
Liquid temperature	32-140 °F (0-60 °C).
Ambient temperature	Max. 131 °F (+55 °C). Min. -4 °F (-20 °C).
Relative humidity	Max. 95 %.
Enclosure class	IP55.
Insulation class	F.
Sound pressure level	The sound pressure level of the pump is below 55 dB(A).
Supply voltage	1 x 115 V, 60 Hz, 1 x 200-240 V, 60 Hz.
Start/stop frequency	Max. 100 per hour.
Cut-in pressure	7.25 psi (0.5 bar) below setpoint.

Electrical data

Pump type	Voltage [V]	I _{max} [A]	P1 [W]
CMBE 1 x 200-240 V			
CMBE 1-44	1 x 200-240	3.4 - 2.9	685
CMBE 1-75	1 x 200-240	6.55 - 5.45	969
CMBE 1-99	1 x 200-240	6.55 - 5.45	1050
CMBE 3-30	1 x 200-240	6.55 - 5.45	815
CMBE 3-62	1 x 200-240	6.55 - 5.45	1220
CMBE 3-93	1 x 200-240	8.9 - 7.45	1300
CMBE 5-31	1 x 200-240	6.55 - 5.45	1300
CMBE 5-62	1 x 200-240	8.9 - 7.45	1400
CMBE 10-27	1 x 200-240	6.55 - 5.45	1190
CMBE 10-54	1 x 200-240	9.1 - 7.6	1250
CMBE 1 x 115 V			
CMBE 1-44	1 x 115	8	1100
CMBE 1-75	1 x 115	8	1100
CMBE 3-30	1 x 115	8	1100
CMBE 3-51	1 x 115	8	1100

Approvals

Drinking water certifications:



TM06 3626 02/15

1 x 230 V CMBE models: UL Listed Packaged Pumping System



TM06 3627 02/15

Wetted parts

The table below specifies the parts of the pump that are in contact with the pumped liquid.

Designation	Material	Technical description
Pump sleeve	Stainless steel	AISI 304 / EN 1.4301
Impeller	Stainless steel	AISI 304 / EN 1.4301
Diffuser	Technopolymer	PP 20 % Talc
Ejector	Technopolymer	PPE/PS 20 % GF
Nozzle	Stainless steel	AISI 304 / EN 1.4301
Shaft	Stainless steel	AISI 304 / EN 1.4301
Shaft seal	Carbon with resin/ceramic	CVBP
Filling plug	Technopolymer	PES 30 % GF
Drain plug	Technopolymer	PES 30 % GF

Dimensional drawings, CMBE

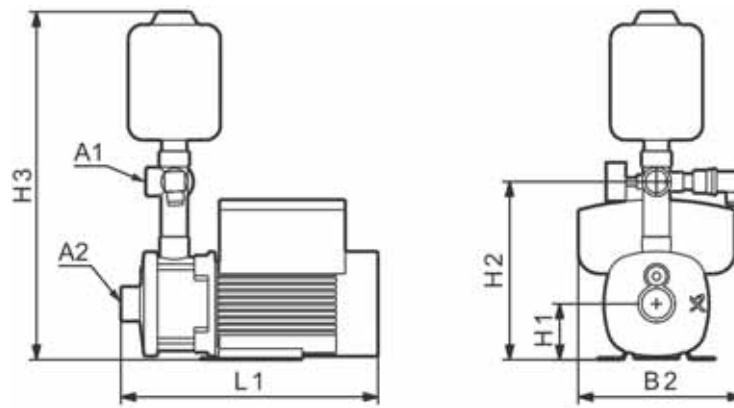

TM06 0802_0914

Pump type	H1 [in (mm)]	H2 [in (mm)]	H3 [in (mm)]	L1 [in (mm)]	B2 (L2) [in (mm)]	A1 [in]	A2 [in]
CMBE 1-44	2.95 (75)	7.87 (200)	17.32 (440)	12.83 (326)	8.54 (217)	1 NPT	1 NPT
	2.95 (75)	7.87 (200)	17.32 (440)	12.83 (326)	8.54 (217)	1 NPT	1 NPT
CMBE 1-75	2.95 (75)	7.87 (200)	17.32 (440)	12.83 (326)	8.54 (217)	1 NPT	1 NPT
	2.95 (75)	7.87 (200)	17.32 (440)	14.25 (362)	8.54 (217)	1 NPT	1 NPT
CMBE 1-99	2.95 (75)	7.87 (200)	17.32 (440)	15.66 (398)	8.54 (217)	1 NPT	1 NPT
CMBE 3-30	2.95 (75)	7.87 (200)	17.32 (440)	12.83 (326)	8.54 (217)	1 NPT	1 NPT
	2.95 (75)	7.87 (200)	17.32 (440)	12.83 (326)	8.54 (217)	1 NPT	1 NPT
CMBE 3-51	2.95 (75)	7.87 (200)	17.32 (440)	12.83 (326)	8.54 (217)	1 NPT	1 NPT
CMBE 3-62	2.95 (75)	7.87 (200)	17.32 (440)	13.54 (344)	8.54 (217)	1 NPT	1 NPT
CMBE 3-93	3.54 (90)	8.46 (215)	17.91 (455)	15.90 (404)	8.54 (217)	1 NPT	1 NPT
CMBE 5-31	2.95 (75)	7.87 (200)	17.32 (440)	12.83 (326)	8.54 (217)	1 NPT	1 1/4 NPT
CMBE 5-62	3.54 (90)	8.46 (215)	17.91 (455)	13.77 (350)	8.54 (217)	1 NPT	1 1/4 NPT
CMBE 10-54	3.62 (92)	9.96 (253)	20.07 (510)	14.84 (377)	9.13 (232)	1 1/2 NPT	1 1/2 NPT

Materials

Designation	Material
Terminal box	Composite PC/ASA and silumin (Alu)
Stator housing	Silumin (Alu)
Fan cover	Composite PBT/PC
Pump housing	Stainless steel, AISI 304 / EN 1.4301
Shaft and impeller	Stainless steel, AISI 304 / EN 1.4301
Flange	Cast iron

Control panel

The control panel on the E-pump terminal box makes it possible to change the setpoint settings manually.

The operating condition of the pump is indicated by the Grundfos Eye on the control panel.

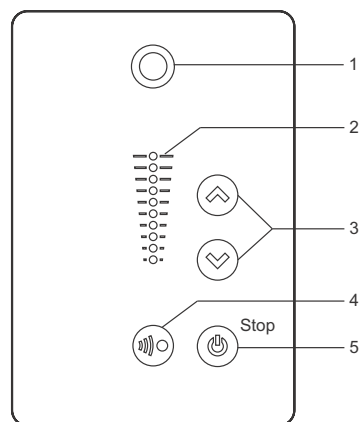

TM05 4848 3512

Fig. 13 Control panel

Pos.	Symbol	Description
1		Grundfos Eye Shows the operating status of the pump.
2	-	Light fields for indication of setpoint.
3		Changes the setpoint.
4		Enables radio communication with the Grundfos GO Remote and other products of the same type.
5		Makes the pump ready for operation/ starts and stops the pump. Start: If the button is pressed when the pump is stopped, the pump will only start if no other functions with higher priority have been enabled. Stop: If the button is pressed when the pump is running, the pump will always be stopped. When the pump is stopped via this button, the "Stop" text next to the button will illuminate.

Performance curves

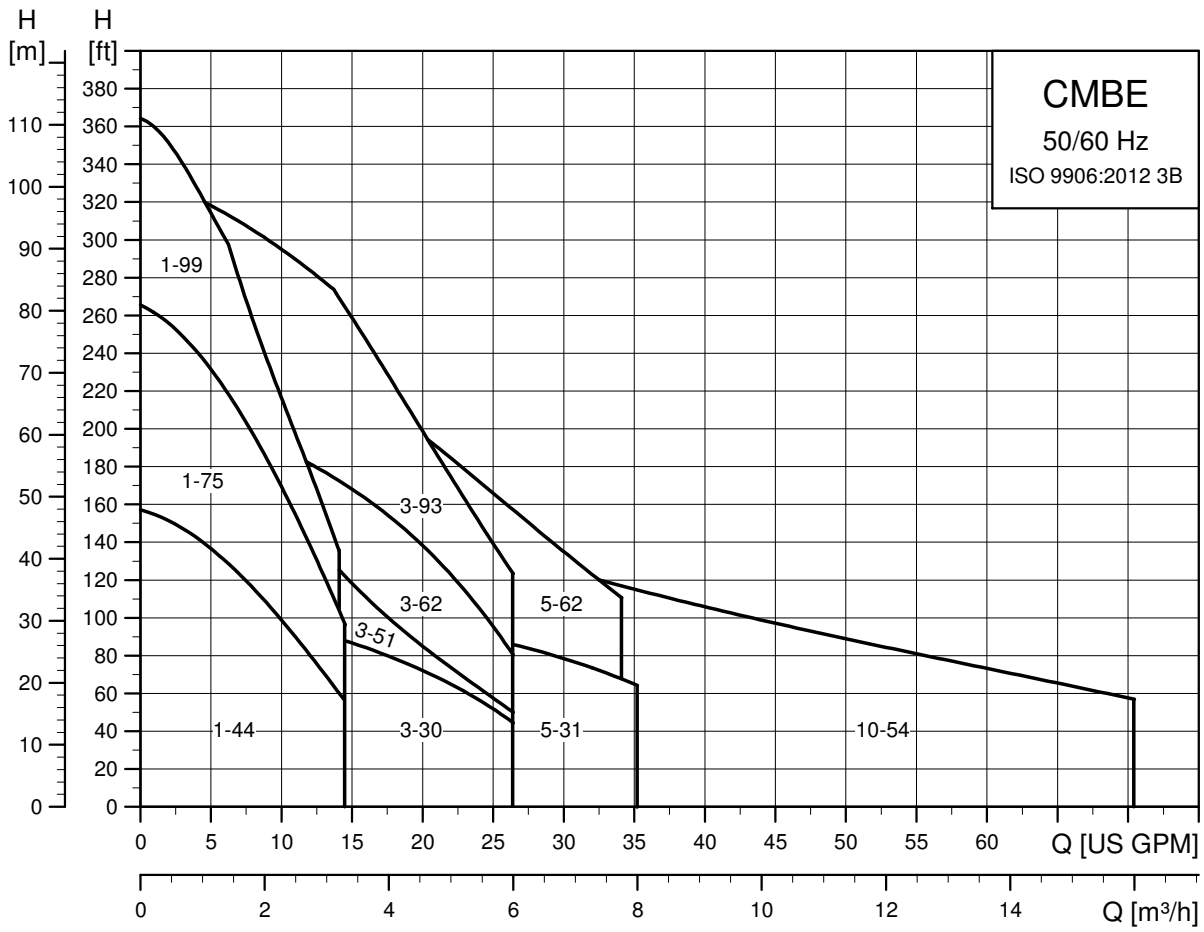

TM06 1420 0614

4. Product numbers

CMBE TWIN

With integrated variable frequency drive.

CMBE TWIN 1 x 220-240 V, 60 Hz

Pump type	Product number
CMBE 10, 1 x 200-240 V, 60 Hz	
CMBE TWIN 10-54	99503875

CMBE TWIN 1 x 115 V, 60 Hz

Pump type	Product number
CMBE 1, 1 x 115 V, 60 Hz	
CMBE TWIN 1-44	99503861
CMBE 3, 1 x 115 V, 60 Hz	
CMBE TWIN 3-51	99503873

CMBE

With integrated variable frequency drive.

CMBE 1 x 200-240 V, 60 Hz

Pump type	Product number
CMBE 1, 1 x 200-240 V, 60 Hz	
CMBE 1-44	98548109
CMBE 1-75	98548110
CMBE 1-99	98548111
CMBE 3, 1 x 200-240 V, 60 Hz	
CMBE 3-30	98548112
CMBE 3-62	98548113
CMBE 3-93	98548114
CMBE 5, 1 x 200-240 V, 60 Hz	
CMBE 5-31	98548115
CMBE 5-62	98548116
CMBE 10, 1 x 200-240 V, 60 Hz	
CMBE 10-54	98548118

CMBE 1 x 115 V, 60 Hz

Pump type	Product number
CMBE 1, 1 x 115 V, 60 Hz	
CMBE 1-44	98810910
CMBE 1-75	98810921
CMBE 3, 1 x 115 V, 60 Hz	
CMBE 3-30	98810922
CMBE 3-51	98810924

5. Grundfos Product Center

Online search and sizing tool to help you make the right choice.

<http://product-selection.grundfos.com>



Select between "Products" and "Literature" when searching for the document.

"SIZING" enables you to size a pump based on entered data and selection choices.

"REPLACEMENT" enables you to find a replacement product. Search results will include information on the following:

- the lowest purchase price
- the lowest energy consumption
- the lowest total life cycle cost.

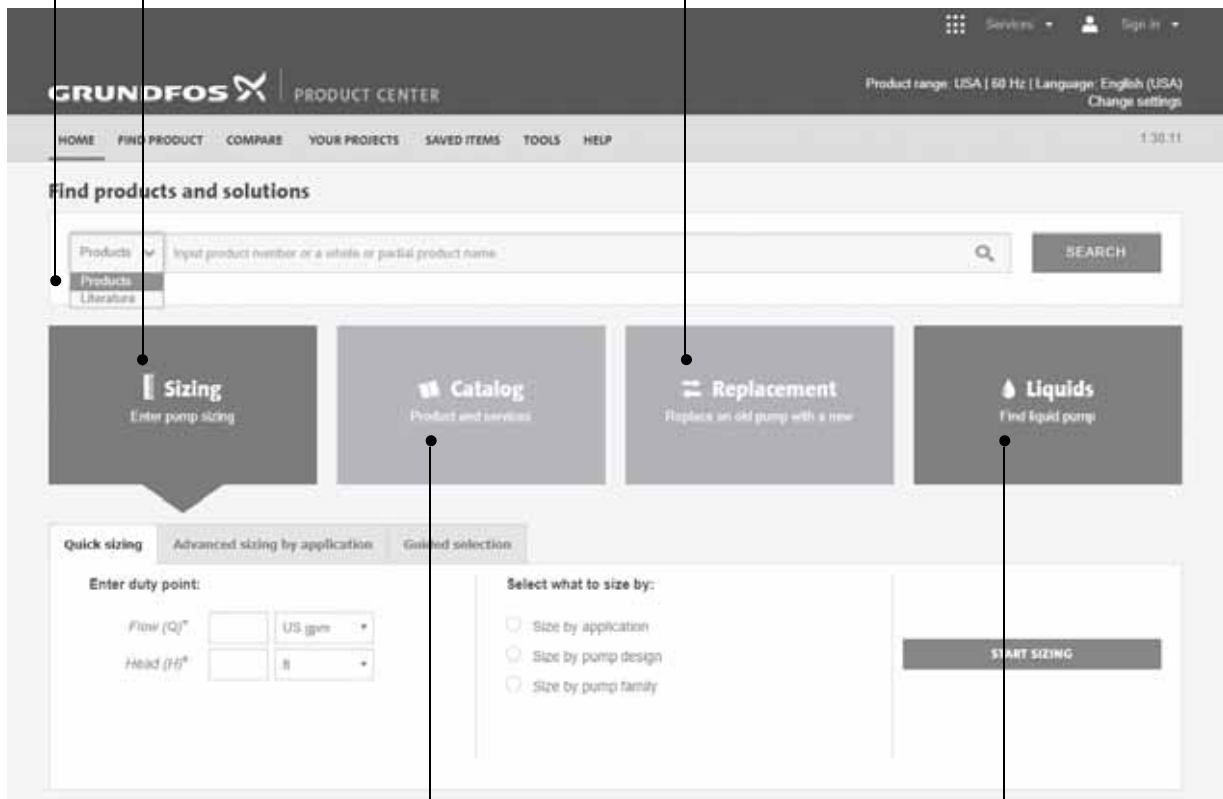

"CATALOG" gives you access to the Grundfos product catalog.

"LIQUIDS" enables you to find pumps designed for aggressive, flammable or other special liquids.

All the information you need in one place

Performance curves, technical specifications, pictures, dimensional drawings, motor curves, wiring diagrams, spare parts, service kits, 3D drawings, documents, system parts. The Product Center displays any recent and saved items - including complete projects - right on the main page.

Downloads

On the product pages, you can download installation and operating instructions, data booklets, service instructions, etc. in PDF format.

98647967 0219

ECM: 1255918

Grundfos Kansas City

9300 Loiret Boulevard
Lenexa, Kansas 66219
Phone: 913-227-3400
Fax: 913-227-3500
www.grundfos.us

Grundfos Canada

2941 Brighton Road
Oakville, Ontario L6H 6C9 Canada
Phone: +1-905-829-9533
Fax: +1-905-829-9512
www.grundfos.ca

Grundfos México

Boulevard TLC No. 15
Parque Industrial Stiva Aeropuerto
C.P. 66600 Apodaca, N.L. Mexico
Phone: 011-52-81-8144 4000
Fax: 011-52-81-8144 4010
www.grundfos.mx