

PROJECT: _____	UNIT TAG: _____	QUANTITY: _____
REPRESENTATIVE: _____	TYPE OF SERVICE: _____	DATE: _____
ENGINEER: _____	SUBMITTED BY: _____	DATE: _____
CONTRACTOR: _____	APPROVED BY: _____	DATE: _____
	ORDER NO.: _____	DATE: _____

### CRE 3-12 N-FGJ-A-E-HQQE

Vertical, multistage centrifugal pump with integrated frequency converter. Pump materials in contact with the liquid are in stainless steel (EN 1.4301)



Product photo could vary from the actual product

Conditions of Service	Pump Data	Motor Data
Efficiency: _____	Max pressure at stated temperature: 363 psi / 250 °F	Rated power - P2: 2 HP
Liquid: Water	Liquid temperature range: -4 .. 248 °F	Rated voltage: 440-480 V
Temperature: 68 °F	Maximum ambient temperature: 122 °F	Main frequency: 60 Hz
NPSH required: ft	Approvals: CURUS, NSF/ANSI 61	Enclosure class: IP55
Specific Gravity: 1.000	Shaft seal: HQQE	Insulation class: F
	Product number: 99340830	Motor protection: ELEC
		Motor type: 90C
		Eff. 1/1: 89.4 %

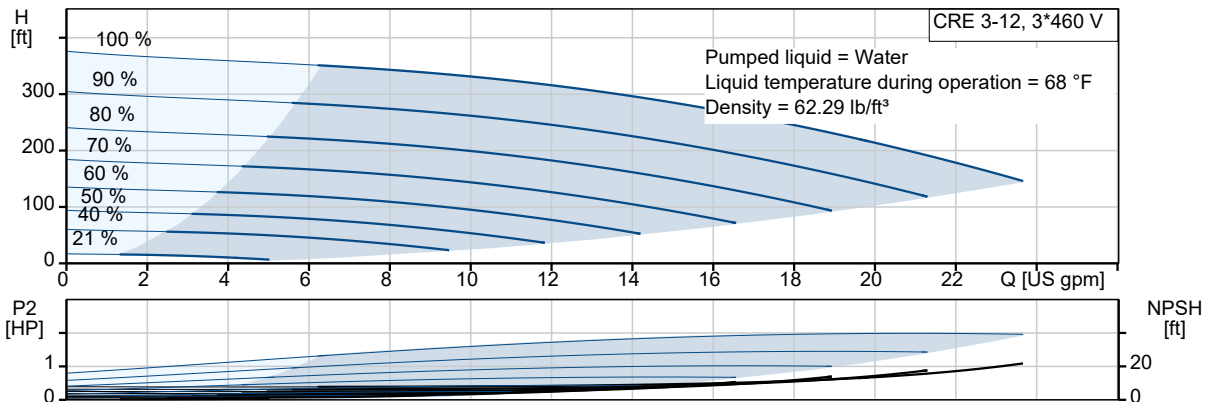

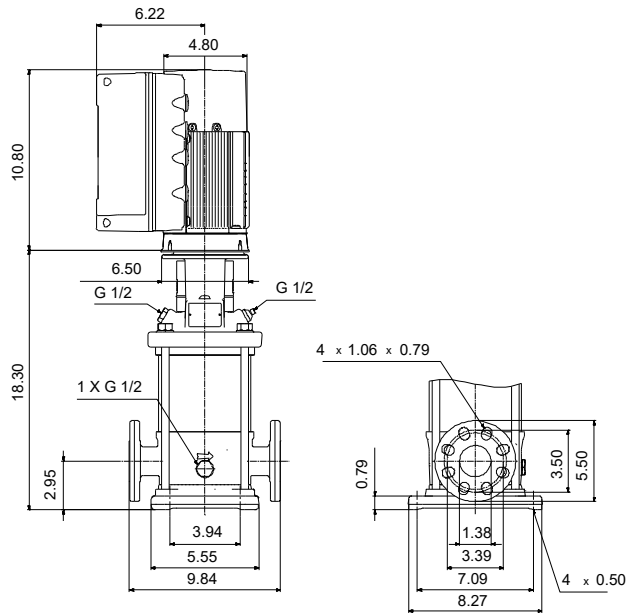

**Materials:**

Base: Cast iron  
 Base: EN 1561 EN-GJL-200  
 Base: ASTM A48-25B  
 Impeller: Stainless steel  
 Impeller: AISI 304  
 Impeller: EN 1.4301  
 Material code: A  
 Code for rubber: E

Count	Description
1	<p data-bbox="298 415 610 443"><b>CRE 3-12 N-FGJ-A-E-HQQE</b></p> <div data-bbox="425 457 526 699" style="text-align: center;">  </div> <p data-bbox="298 732 558 760">Product No.: <a href="#">99340830</a></p> <p data-bbox="298 793 1409 890">Vertical, multistage centrifugal pump with inlet and outlet ports on same the level (inline). The pump head and base are in cast iron – all other wetted parts are in stainless steel. A cartridge shaft seal ensures high reliability, safe handling, and easy access and service. Power transmission is via a rigid split coupling. Pipe connection is via combined DIN-ANSI-JIS flanges.</p> <p data-bbox="298 934 1409 1094">The pump is fitted with a 3-phase, fan-cooled, permanent-magnet, synchronous motor. The motor efficiency is classified as IE5 in accordance with IEC 60034-30-2. The motor includes a frequency converter and PI controller in the motor terminal box. This enables continuously variable control of the motor speed, which again enables adaptation of the performance to a given requirement. The operating panel on the motor terminal box features a four-inch TFT display, push-buttons and the Grundfos Eye indicator.</p> <p data-bbox="298 1138 1409 1241">The display gives an intuitive and user-friendly interface to all functions. The push-buttons are used to navigate through the menu structure to access pump and performance data on site and enable setting of required setpoint as well as setting of pump to "Min." or "Max." operation or to "Stop".</p> <p data-bbox="298 1310 1409 1381">Communication with the pump is also possible by means of Grundfos GO Remote (accessory). The remote control enables further settings as well as reading out of a number of parameters such as "Actual value", "Speed", "Power input" and total "Power consumption".</p> <p data-bbox="298 1430 1409 1598">The Grundfos Eye indicator on the operating panel provides visual indication of pump status:</p> <ul data-bbox="337 1457 1377 1598" style="list-style-type: none"> <li>• "Power on": Motor is running (rotating green indicator lights) or not running (permanently green indicator lights)</li> <li>• "Warning": Motor is still running (rotating yellow indicator lights) or has stopped (permanently yellow indicator lights)</li> <li>• "Alarm": Motor has stopped (flashing red indicator lights).</li> </ul> <p data-bbox="298 1633 1409 1682">The terminal box has a number of inputs and outputs enabling the motor to be used in advanced applications where many inputs and outputs are required:</p> <ul data-bbox="337 1688 1377 1894" style="list-style-type: none"> <li>• two dedicated digital inputs</li> <li>• three analog inputs, 0(4)-20 mA, 0-5 V, 0-10 V, 0.5 - 3.5 V; the factory-fitted pressure sensor is connected to one of these inputs</li> <li>• 5 V voltage supply to potentiometer and sensor</li> <li>• one analog output, 0-10 V, 0(4)-20 mA</li> <li>• two configurable digital inputs or open-collector outputs</li> <li>• two Pt100/Pt1000 inputs</li> </ul>



Company name:

Created by:

Phone:

Date:

4/6/2021

Count	Description
	<ul style="list-style-type: none"><li>• LiqTec, dry-running protection sensor input</li><li>• Grundfos Digital Sensor input and output</li><li>• 24 V voltage supply for sensors</li><li>• two signal-relay outputs (potential-free contacts)</li><li>• GENIbus connection</li><li>• interface for Grundfos CIM fieldbus module.</li></ul> <p><b>Further product details</b></p> <p>The pump is equipped with a pressure sensor registering pump outlet pressure and enabling controlled pump operation based on constant pressure.</p> <p>The operating panel on the motor terminal box features a four-inch TFT display, push-buttons and the Grundfos Eye indicator.</p> <p>The display gives an intuitive and user-friendly interface to all functions.</p> <p>The push-buttons are used to navigate through the menu structure to access pump and performance data on site and enable setting of required setpoint as well as setting of pump to "Min." or "Max." operation or to "Stop".</p> <p>Communication with the pump is also possible by means of Grundfos GO Remote (accessory). The remote control enables further settings as well as reading out of a number of parameters such as "Actual value", "Speed", "Power input" and total "Power consumption".</p> <p>The Grundfos Eye indicator on the operating panel provides visual indication of pump status:</p> <ul style="list-style-type: none"><li>• "Power on": Motor is running (rotating green indicator lights) or not running (permanently green indicator lights)</li><li>• "Warning": Motor is still running (rotating yellow indicator lights) or has stopped (permanently yellow indicator lights)</li><li>• "Alarm": Motor has stopped (flashing red indicator lights).</li></ul> <p>Steel, cast iron and aluminium components have an epoxy-based coating made in a cathodic electro-deposition (CED) process.</p> <p>CED is a high-quality dip-painting process where an electrical field around the products ensures deposition of paint particles as a thin, well-controlled layer on the surface.</p> <p>An integral part of the process is a pretreatment.</p> <p>The entire process consists of these elements:</p> <ol style="list-style-type: none"><li>1) Alkaline-based cleaning.</li><li>2) Zinc phosphating.</li><li>3) Cathodic electro-deposition.</li><li>4) Curing to a dry film thickness 18-22 my m.</li></ol> <p>The colour code for the finished product is NCS 9000/RAL 9005.</p> <p><b>Pump</b></p> <p>A standard split coupling connects the pump and motor shaft. It is enclosed in the pump head/motor stool by means of two coupling guards.</p>

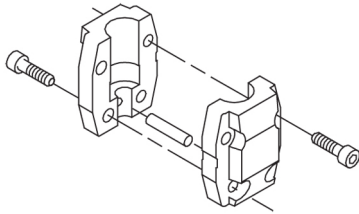

The pump head, pump head cover and flange for motor mounting is made in one piece. The pump head has a combined 1/2" priming plug and vent screw.

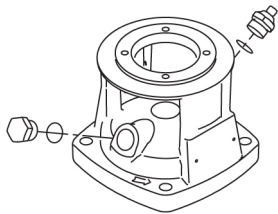

The pump is fitted with a balanced O-ring seal unit with a rigid torque-transmission system. This seal type is assembled in a cartridge unit which makes replacement safe and easy. Due to the balancing, this seal type is suitable for high-pressure applications. The cartridge construction also protects the pump shaft from possible wear from a dynamic O-ring between pump shaft and shaft seal.

Primary seal:

- Rotating seal ring material: silicon carbide (SiC)
- Stationary seat material: silicon carbide (SiC)

This material pairing is used where higher corrosion resistance is required. The high hardness of this material pairing offers good resistance against abrasive particles.

Secondary seal material: EPDM (ethylene-propylene rubber)

EPDM has excellent resistance to hot water. EPDM is not suitable for mineral oils.

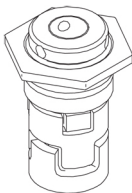

The shaft seal is screwed into the pump head.

The chambers and impellers are made of stainless-steel sheet. The chambers are provided with a PTFE neck ring offering improved sealing and high efficiency. The impellers have smooth surfaces, and the shape of the blades ensure a high efficiency.

The base is made of cast iron. The flanges and base are cast in one piece. The outlet side of the base has a combined drain plug and bypass valve. The pump is secured to the foundation by four bolts through the base plate.

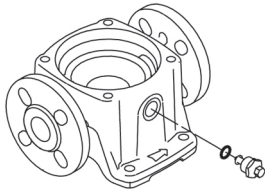

## Motor

The motor is a totally enclosed, fan-cooled motor with principal dimensions to IEC and DIN standards. The motor is flange-mounted with tapped-hole flange (FT).

Motor-mounting designation in accordance with IEC 60034-7: IM B 14 (Code I) / IM 3601 (Code II).

Electrical tolerances comply with IEC 60034.

The motor efficiency is classified as IE5 in accordance with IEC 60034-30-2.

The motor requires no external motor protection. The motor control unit incorporates protection against slow- and quick-rising temperatures, e.g. constant overload and stalled conditions.

## Technical data

### Liquid:

Pumped liquid:	Water
Liquid temperature range:	-4 .. 248 °F
Selected liquid temperature:	68 °F
Density:	62.29 lb/ft <sup>3</sup>

### Technical:

Rated pump speed:	3452 rpm
Rated flow:	15.4 US gpm
Rated head:	272.3 ft
Pump orientation:	Vertical
Shaft seal arrangement:	Single
Code for shaft seal:	HQQE
Approvals on nameplate:	CURUS,NSF/ANSI 61
Curve tolerance:	ISO9906:2012 3B

### Materials:

Base:	Cast iron EN 1561 EN-GJL-200 ASTM A48-25B
Impeller:	Stainless steel EN 1.4301 AISI 304
Bearing:	SIC SIC

### Installation:

Maximum ambient temperature:	122 °F
Maximum operating pressure:	362.59 psi
Max pressure at stated temperature:	363 psi / 250 °F



Company name:

Created by:

Phone:

Date:

4/6/2021

Count	Description
	363 psi / -4 °F
	Type of connection: DIN / ANSI / JIS
	Size of inlet connection: DN 25/32
	Size of outlet connection: DN 25/32
	Pressure rating for connection: PN 25
	Flange rating inlet: 250 lb
	Flange size for motor: 56C
	Electrical data:
	Motor standard: NEMA
	Motor type: 90C
	IE Efficiency class: IE5
	Rated power - P2: 2 HP
	Power (P2) required by pump: 2 HP
	Main frequency: 60 Hz
	Rated voltage: 3 x 440-480 V
	Service factor: 1.15
	Rated current: 2.65 A
	Cos phi - power factor: 0.87
	Rated speed: 360-4000 rpm
	IE efficiency: 89.4%
	Motor efficiency at full load: 89.4 %
	Enclosure class (IEC 34-5): IP55
	Insulation class (IEC 85): F
	Motor Number: 98362281
	Controls:
	Frequency converter: Built-in
	Pressure sensor: Y
	Others:
	Net weight: 82 lb
	Gross weight: 96.5 lb
	Shipping volume: 8.26 ft <sup>3</sup>
	Country of origin: US
	Custom tariff no.: 8413.70.2040



Company name:  
Created by:  
Phone:

Date: 4/6/2021

### 99340830 CRE 3-12 N-FGJ-A-E-HQQE 60 Hz

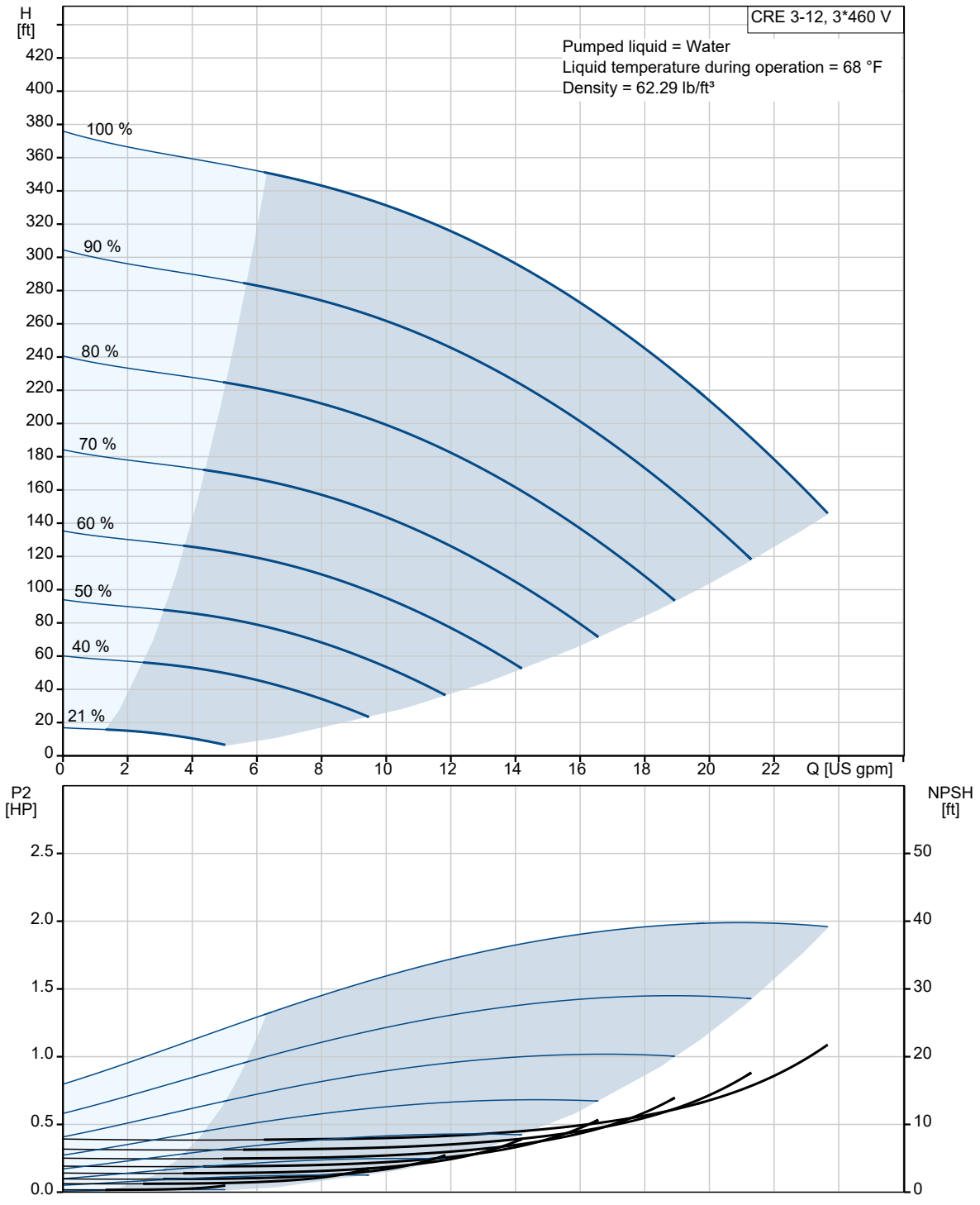



Description	Value
<b>General information:</b>	
Product name:	CRE 3-12 N-FGJ-A-E-HQQE
Product No.:	99340830
EAN:	5713827514852
<b>Technical:</b>	
Rated pump speed:	3452 rpm
Rated flow:	15.4 US gpm
Rated head:	272.3 ft
Maximum head:	373.4 ft
Stages:	12
Impellers:	12
Number of reduced-diameter impellers:	0
Low NPSH:	N
Pump orientation:	Vertical
Shaft seal arrangement:	Single
Code for shaft seal:	HQQE
Approvals on nameplate:	CURUS, NSF/ANSI 61
Curve tolerance:	ISO9906:2012 3B
Pump version:	N
Model:	A
<b>Materials:</b>	
Base:	Cast iron
Base:	EN 1561 EN-GJL-200
Base:	ASTM A48-25B
Impeller:	Stainless steel
Impeller:	EN 1.4301
Impeller:	AISI 304
Material code:	A
Code for rubber:	E
Bearing:	SIC
Bearing:	SIC
<b>Installation:</b>	
Maximum ambient temperature:	122 °F
Maximum operating pressure:	362.59 psi
Max pressure at stated temperature:	363 psi / 250 °F
Max pressure at stated temperature:	363 psi / -4 °F
Type of connection:	DIN / ANSI / JIS
Size of inlet connection:	DN 25/32
Size of outlet connection:	DN 25/32
Pressure rating for connection:	PN 25
Flange rating inlet:	250 lb
Flange size for motor:	56C
Connect code:	FGJ
<b>Liquid:</b>	
Pumped liquid:	Water

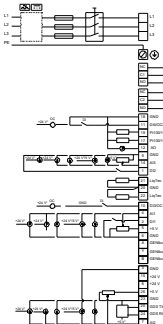
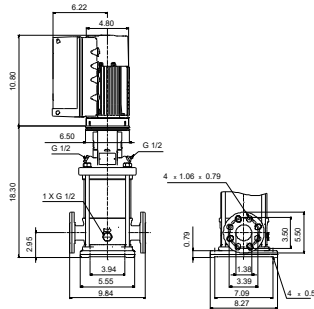
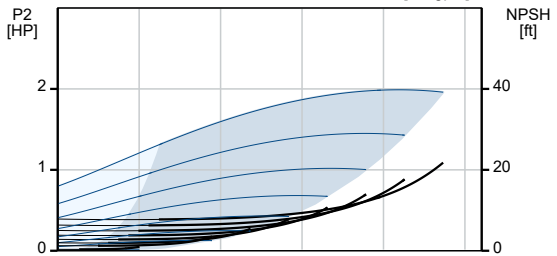
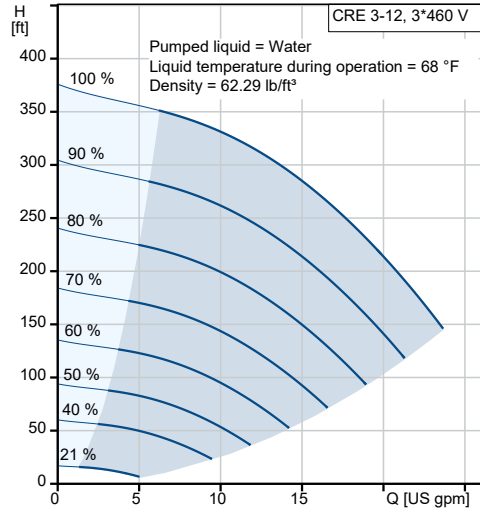



Company name:

Created by:

Phone:

Date:

4/6/2021

Description	Value
Liquid temperature range:	-4 .. 248 °F
Selected liquid temperature:	68 °F
Density:	62.29 lb/ft <sup>3</sup>
<b>Electrical data:</b>	
Motor standard:	NEMA
Motor type:	90C
IE Efficiency class:	IE5
Rated power - P2:	2 HP
Power (P2) required by pump:	2 HP
Main frequency:	60 Hz
Rated voltage:	3 x 440-480 V
Service factor:	1.15
Rated current:	2.65 A
Cos phi - power factor:	0.87
Rated speed:	360-4000 rpm
IE efficiency:	89.4%
Motor efficiency at full load:	89.4 %
Enclosure class (IEC 34-5):	IP55
Insulation class (IEC 85):	F
Motor protection:	ELEC
Motor Number:	98362281
<b>Controls:</b>	
Control panel:	Graphical
Function Module:	FM300 - Advanced
Frequency converter:	Built-in
Pressure sensor:	Y
<b>Others:</b>	
Net weight:	82 lb
Gross weight:	96.5 lb
Shipping volume:	8.26 ft <sup>3</sup>
Config. file no:	98498992
Country of origin:	US
Custom tariff no.:	8413.70.2040



Company name:  
Created by:  
Phone:

Date: 4/6/2021

### 99340830 CRE 3-12 N-FGJ-A-E-HQQE 60 Hz

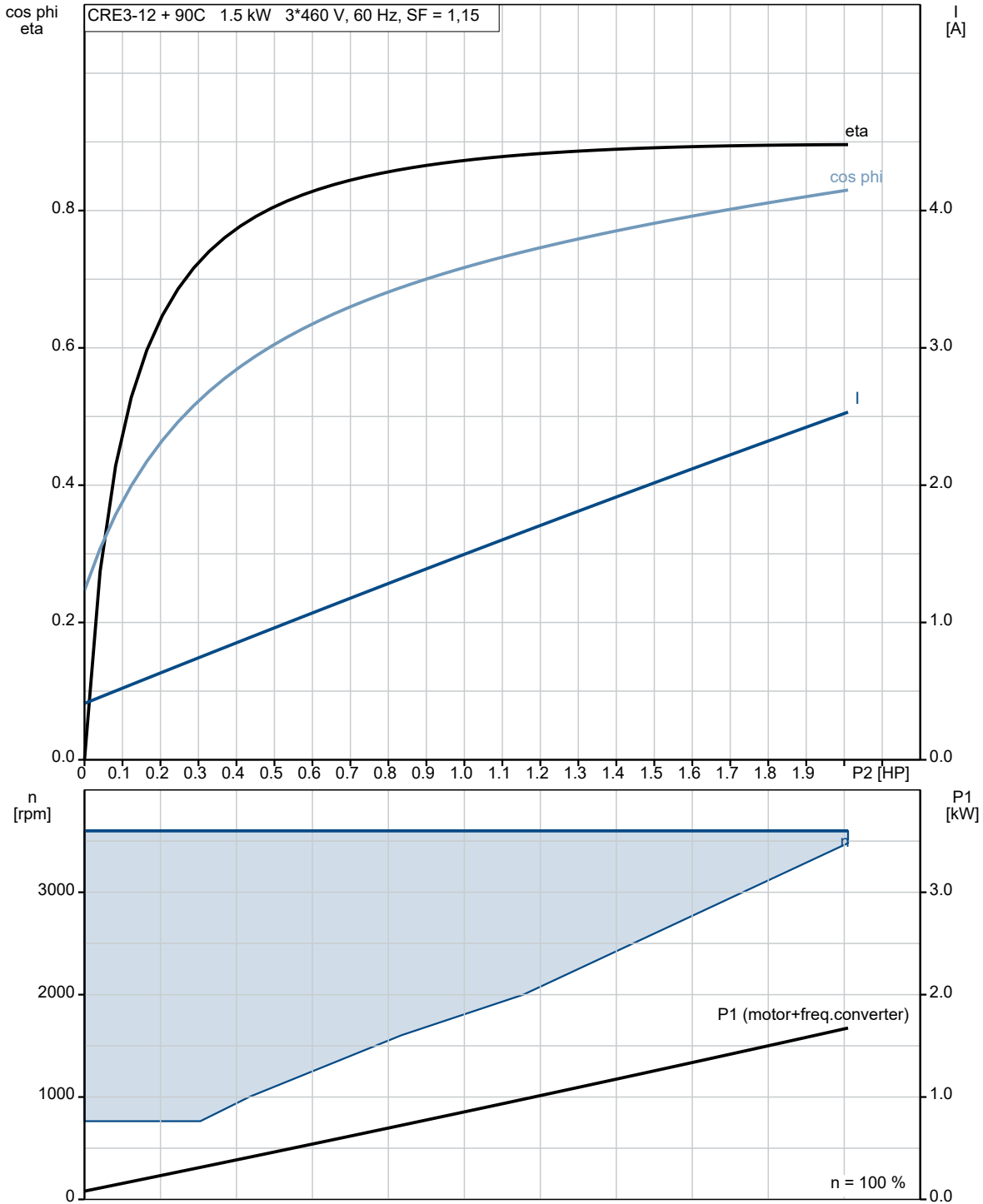

## 99340830 CRE 3-12 N-FGJ-A-E-HQQE 60 Hz

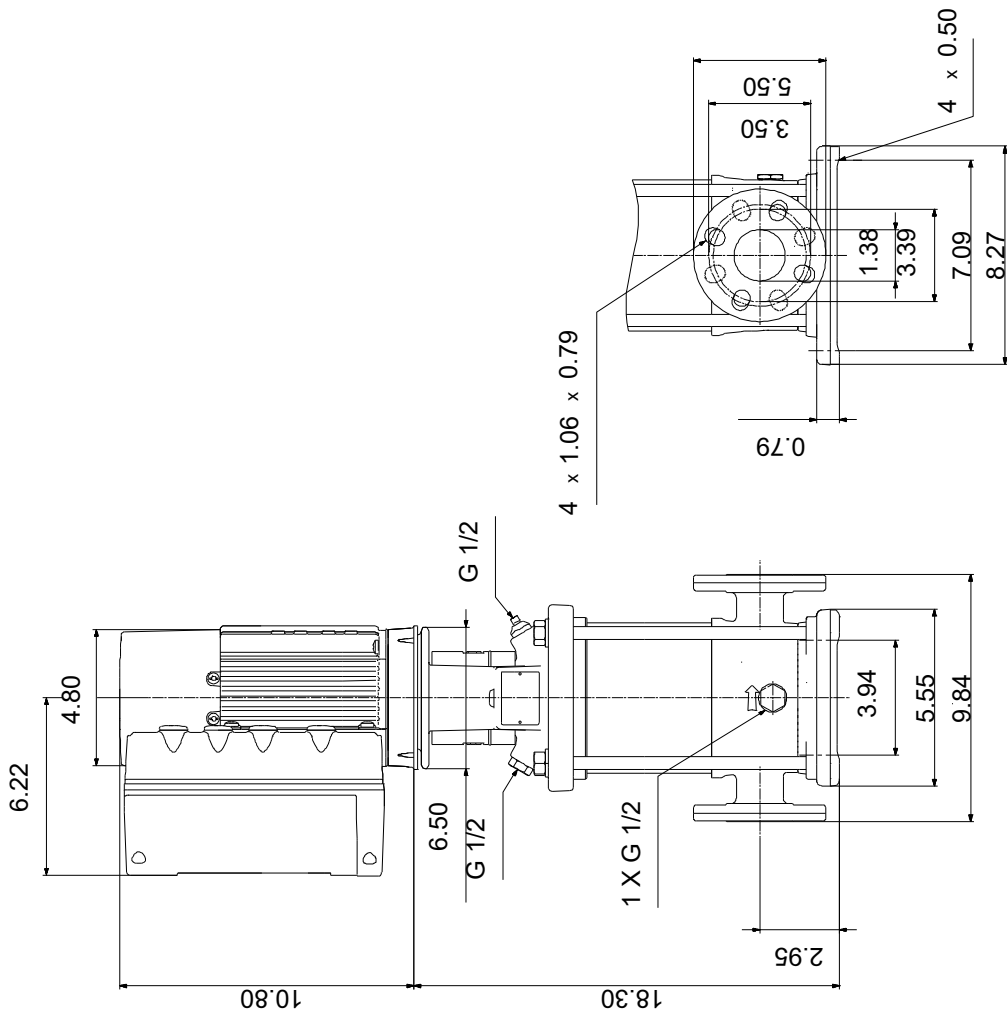

Note! All units are in [in] unless otherwise stated.  
Disclaimer: This simplified dimensional drawing does not show all details.

## 99340830 CRE 3-12 N-FGJ-A-E-HQQE 60 Hz

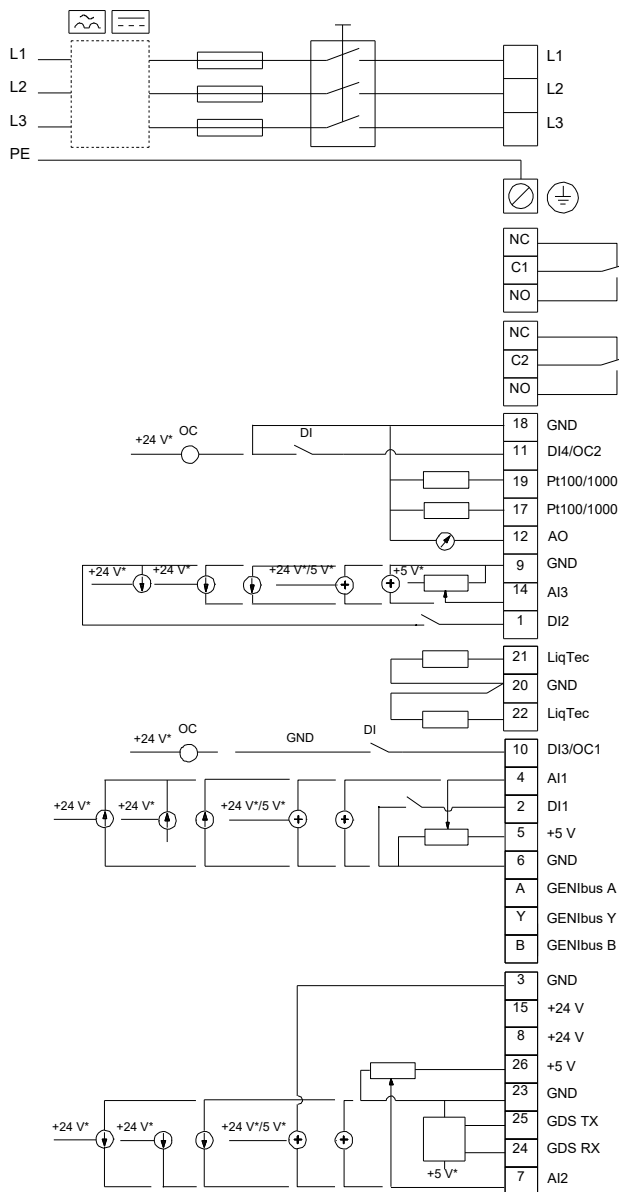

All units are [in] unless otherwise presented.