

PROJECT: _____	UNIT TAG: _____	QUANTITY: _____
REPRESENTATIVE: _____	TYPE OF SERVICE: _____	DATE: _____
ENGINEER: _____	SUBMITTED BY: _____	DATE: _____
CONTRACTOR: _____	APPROVED BY: _____	DATE: _____
	ORDER NO.: _____	DATE: _____



Product photo could vary from the actual product

CR 20-2 A-B-A-V-HQQV

Vertical, multistage centrifugal pump with suction and discharge ports on the same level. The pump head and base are in cast iron. All other wetted parts are in stainless steel (EN 1.4301)(AISI 304)

Conditions of Service	Pump Data	Motor Data
Efficiency: _____	Max pressure at stated temperature: 145 psi / 194 °F	Rated power - P2: 5 HP
Liquid: Water	Liquid temperature range: -4 .. 194 °F	Rated voltage: 208-230 V
Temperature: 68 °F	Maximum ambient temperature: 104 °F	Main frequency: 60 Hz
NPSH required: ft	Shaft seal: HQQV	Enclosure class: IP55
Specific Gravity: 1.000	Product number: 99917723	Insulation class: F
		Motor protection: PTO
		Motor type: WEG
		Eff. 1/1: 84.0 %

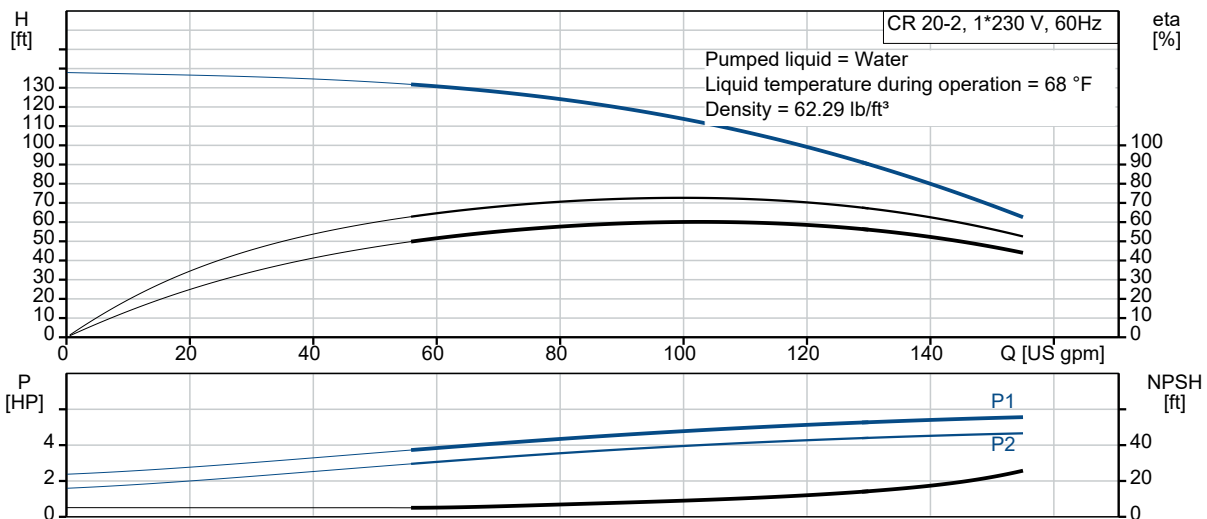

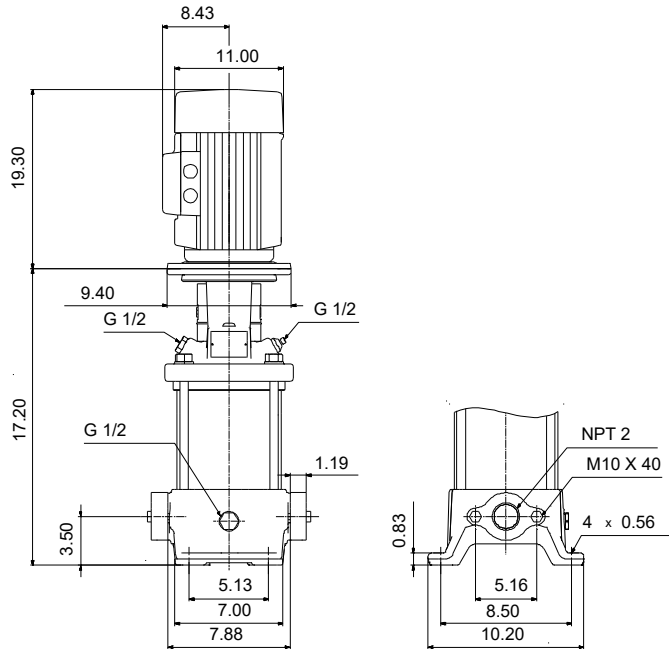

Materials:

Base: Cast iron
 Base: EN 1561 EN-GJL-200
 Base: ASTM A48-25B
 Impeller: Stainless steel
 Impeller: AISI 304
 Impeller: EN 1.4301
 Material code: A
 Code for rubber: V

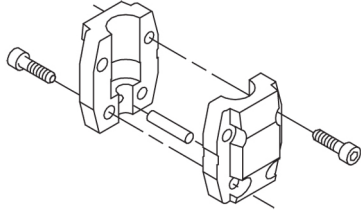
Count	Description
1	<p data-bbox="298 411 565 443">CR 20-2 A-B-A-V-HQQV</p> <div data-bbox="418 472 552 699" style="text-align: center;">  </div> <p data-bbox="298 730 558 758">Product No.: 99917723</p> <p data-bbox="298 789 1409 890">Vertical, multistage centrifugal pump with inlet and outlet ports on same the level (inline). The pump head and base are in cast iron – all other wetted parts are in stainless steel. A cartridge shaft seal ensures high reliability, safe handling, and easy access and service. Power transmission is via a rigid split coupling. Pipe connection is via oval flanges with internal NPT threads.</p> <p data-bbox="298 932 1005 959">The pump is fitted with a 1-phase, fan-cooled asynchronous motor.</p> <p data-bbox="298 991 605 1022">Further product details</p> <p data-bbox="298 1026 1284 1079">Steel, cast iron and aluminium components have an epoxy-based coating made in a cathodic electro-deposition (CED) process.</p> <p data-bbox="298 1083 1312 1136">CED is a high-quality dip-painting process where an electrical field around the products ensures deposition of paint particles as a thin, well-controlled layer on the surface.</p> <p data-bbox="298 1140 812 1167">An integral part of the process is a pretreatment.</p> <p data-bbox="298 1171 792 1199">The entire process consists of these elements:</p> <ol data-bbox="321 1203 792 1318" style="list-style-type: none"> 1) Alkaline-based cleaning. 2) Zinc phosphating. 3) Cathodic electro-deposition. 4) Curing to a dry film thickness 18-22 my m. <p data-bbox="298 1323 980 1350">The colour code for the finished product is NCS 9000/RAL 9005.</p> <p data-bbox="298 1381 378 1413">Pump</p> <p data-bbox="298 1417 1409 1467">A standard split coupling connects the pump and motor shaft. It is enclosed in the pump head/motor stool by means of two coupling guards.</p> <div data-bbox="298 1478 656 1686" style="text-align: center;">  </div> <p data-bbox="298 1711 1398 1764">The pump head, pump head cover and flange for motor mounting is made in one piece. The pump head has a combined 1/2" priming plug and vent screw.</p>

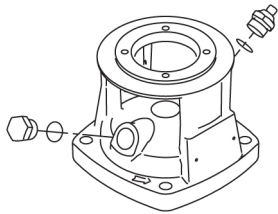

The pump is fitted with a balanced O-ring seal unit with a rigid torque-transmission system.

This seal type is assembled in a cartridge unit which makes replacement safe and easy.

Due to the balancing, this seal type is suitable for high-pressure applications.

The cartridge construction also protects the pump shaft from possible wear from a dynamic O-ring between pump shaft and shaft seal.

Primary seal:

- Rotating seal ring material: silicon carbide (SiC)
- Stationary seat material: silicon carbide (SiC)

This material pairing is used where higher corrosion resistance is required. The high hardness of this material pairing offers good resistance against abrasive particles.

Secondary seal material: FKM (fluorocarbon rubber)

FKM has excellent resistance to oils and chemicals. Above 90 °C, FKM should only be used in media without water.

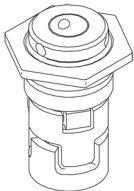

The shaft seal is screwed into the pump head.

The chambers and impellers are made of stainless-steel sheet. The chambers are provided with a PTFE neck ring offering improved sealing and high efficiency. The impellers have smooth surfaces, and the shape of the blades ensure a high efficiency.

The base is made of cast iron. The oval flanges are bolted to the base. The outlet side of the base has a drain plug. The pump is secured to the foundation by four bolts through the base plate.

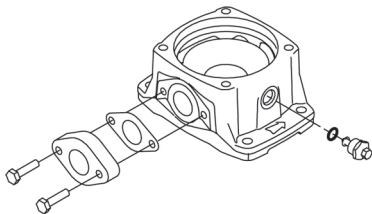

Motor

The motor is a totally enclosed, fan-cooled motor with principal dimensions to IEC and DIN standards. The motor is flange-mounted with tapped-hole flange (FT).

Motor-mounting designation in accordance with IEC 60034-7: IM B 14 (Code I) / IM 3601 (Code II).

Electrical tolerances comply with IEC 60034.



Company name:

Created by:

Phone:

Date:

11/4/2021

Count	Description
	<p>The motor has built-in thermal protection (PTO current and temperature sensors) in accordance with IEC 60034-11 and requires no further motor protection. The protection reacts to both slow- and quick-rising temperatures, e.g. constant overload and stalled conditions.</p> <p>As the thermal protection incorporates automatic reset, the motor must be connected in a way which ensures that the automatic reset cannot cause accidents.</p> <p>Technical data</p> <p>Liquid:</p> <p>Liquid temperature range: -4 .. 194 °F</p> <p>Selected liquid temperature: 68 °F</p> <p>Technical:</p> <p>Materials:</p> <p>Installation:</p> <p>t max amb: 104 °F</p> <p>Maximum operating pressure: 145.04 psi</p> <p>Max pressure at stated temperature: 145 psi / 194 °F 145 psi / -4 °F</p> <p>Electrical data:</p> <p>Power (P2) required by pump: 5 HP</p> <p>Starting current: 800-800 %</p> <p>Controls:</p> <p>Frequency converter: NONE</p> <p>Others:</p> <p>Country of origin: US</p> <p>Custom tariff no.: 8413.70.2040</p>



Company name:
Created by:
Phone:

Date: 11/4/2021

99917723 CR 20-2 A-B-A-V-HQQV 60 Hz

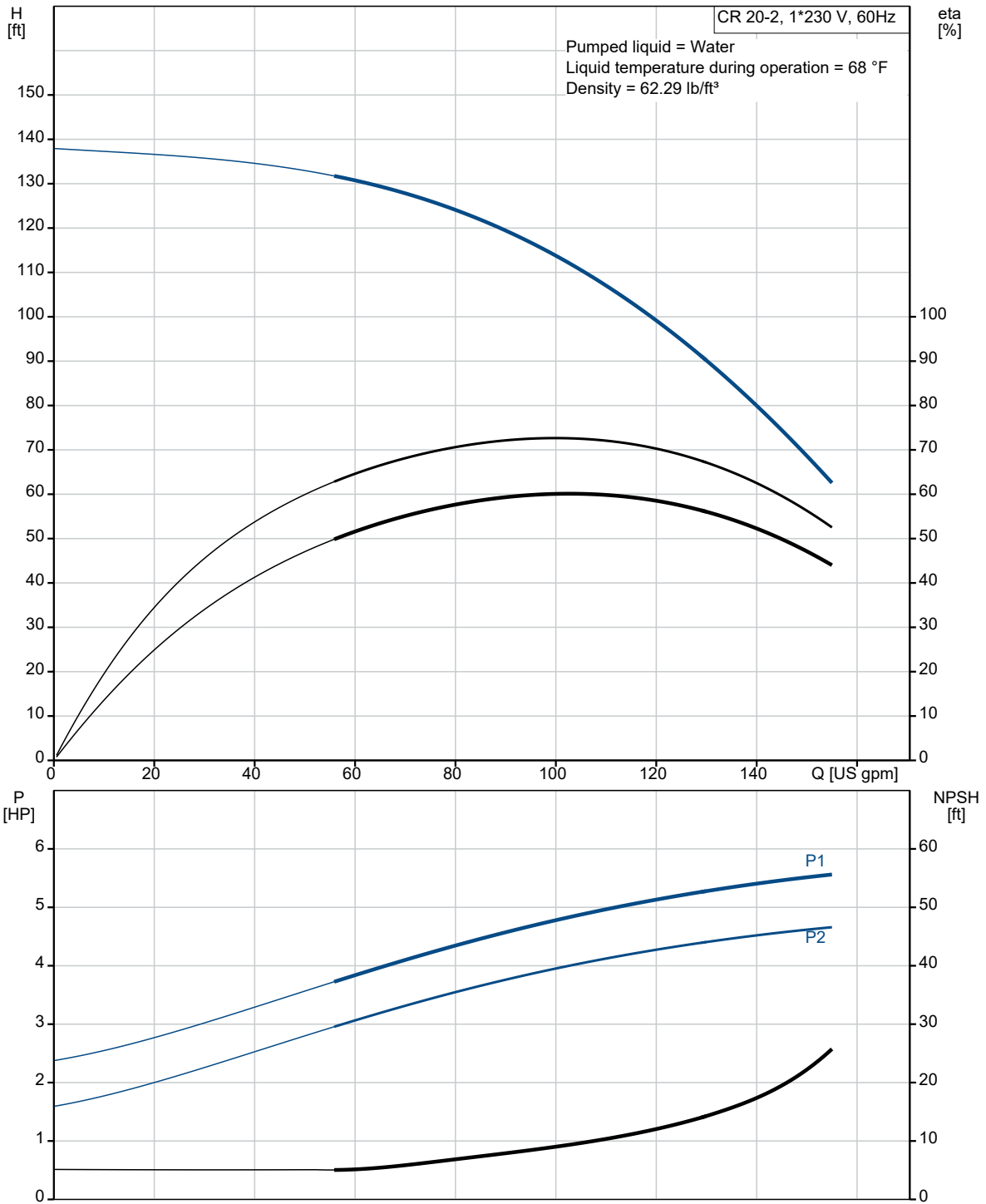



Company name:
Created by:
Phone:

Date: 11/4/2021

Description	Value
General information:	
Product name:	CR 20-2 A-B-A-V-HQQV
Product No.:	99917723
EAN:	5715114125451
Technical:	
Rated pump speed:	3468 rpm
Rated flow:	111 US gpm
Rated head:	104 ft
Maximum head:	136.5 ft
Actual impeller diameter:	4.13 in
Stages:	2
Impellers:	2
Number of reduced-diameter impellers:	0
Low NPSH:	N
Pump orientation:	Vertical
Shaft seal arrangement:	Single
Code for shaft seal:	HQQV
Approvals:	CURUS
Curve tolerance:	ISO9906:2012 3B
Pump version:	A
Model:	A
Cooling:	IC 411
Materials:	
Base:	Cast iron
Base:	EN 1561 EN-GJL-200
Base:	ASTM A48-25B
Impeller:	Stainless steel
Impeller:	EN 1.4301
Impeller:	AISI 304
Material code:	A
Code for rubber:	V
Bearing:	SIC
Installation:	
t max amb:	104 °F
Maximum operating pressure:	145.04 psi
Max pressure at stated temperature:	145 psi / 194 °F
Max pressure at stated temperature:	145 psi / -4 °F
Type of connection:	Oval / NPT(F)
Size of suction port:	2 inch
Size of outlet port:	2 inch
Pressure rating for connection:	PN 10
Flange size for motor:	182TC
Connect code:	B
Liquid:	
Pumped liquid:	Water
Liquid temperature range:	-4 .. 194 °F
Selected liquid temperature:	68 °F

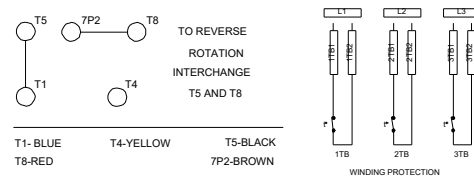
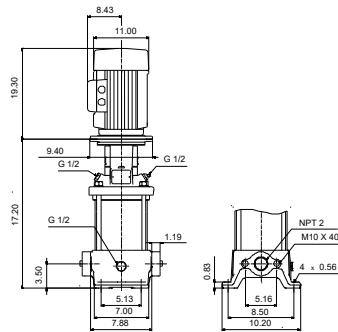
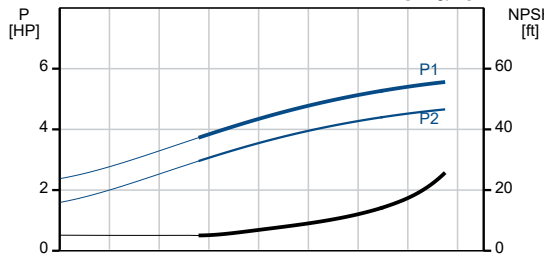
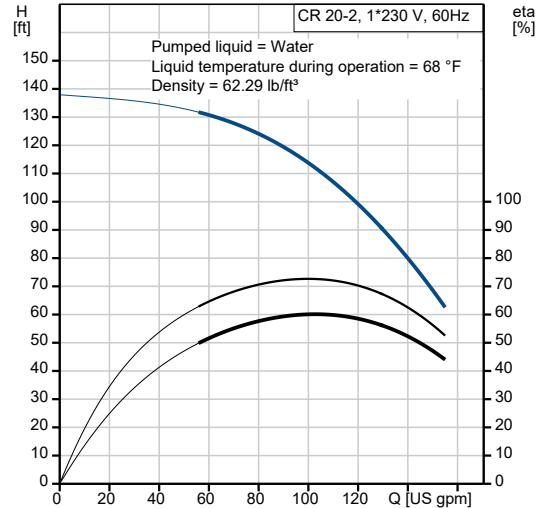



Company name:

Created by:

Phone:

Date: 11/4/2021

Description	Value
Density:	62.29 lb/ft ³
Electrical data:	
Motor standard:	NEMA
Motor type:	WEG
Rated power - P2:	5 HP
Power (P2) required by pump:	5 HP
Main frequency:	60 Hz
Rated voltage:	1 x 208-230 V
Service factor:	1.15
Rated current:	31.7-25.3 A
Starting current:	800-800 %
Full load SF current:	31.7/22.4 A
Cos phi - power factor:	0.98
Rated speed:	3515 rpm
IE efficiency:	84.0%
Motor efficiency at full load:	84.0 %
Motor efficiency at 3/4 load:	82.0 %
Motor efficiency at 1/2 load:	76.4 %
Number of poles:	2
Enclosure class (IEC 34-5):	IP55
Insulation class (IEC 85):	F
Built-in motor protection:	PTO
Motor Number:	99883304
Controls:	
Frequency converter:	NONE
Others:	
DOE Pump Energy Index CL:	0.91
Net weight:	218 lb
Gross weight:	234 lb
Shipping volume:	13.1 ft ³
Country of origin:	US
Custom tariff no.:	8413.70.2040



Company name:
Created by:
Phone:

Date: 11/4/2021

99917723 CR 20-2 A-B-A-V-HQQV 60 Hz

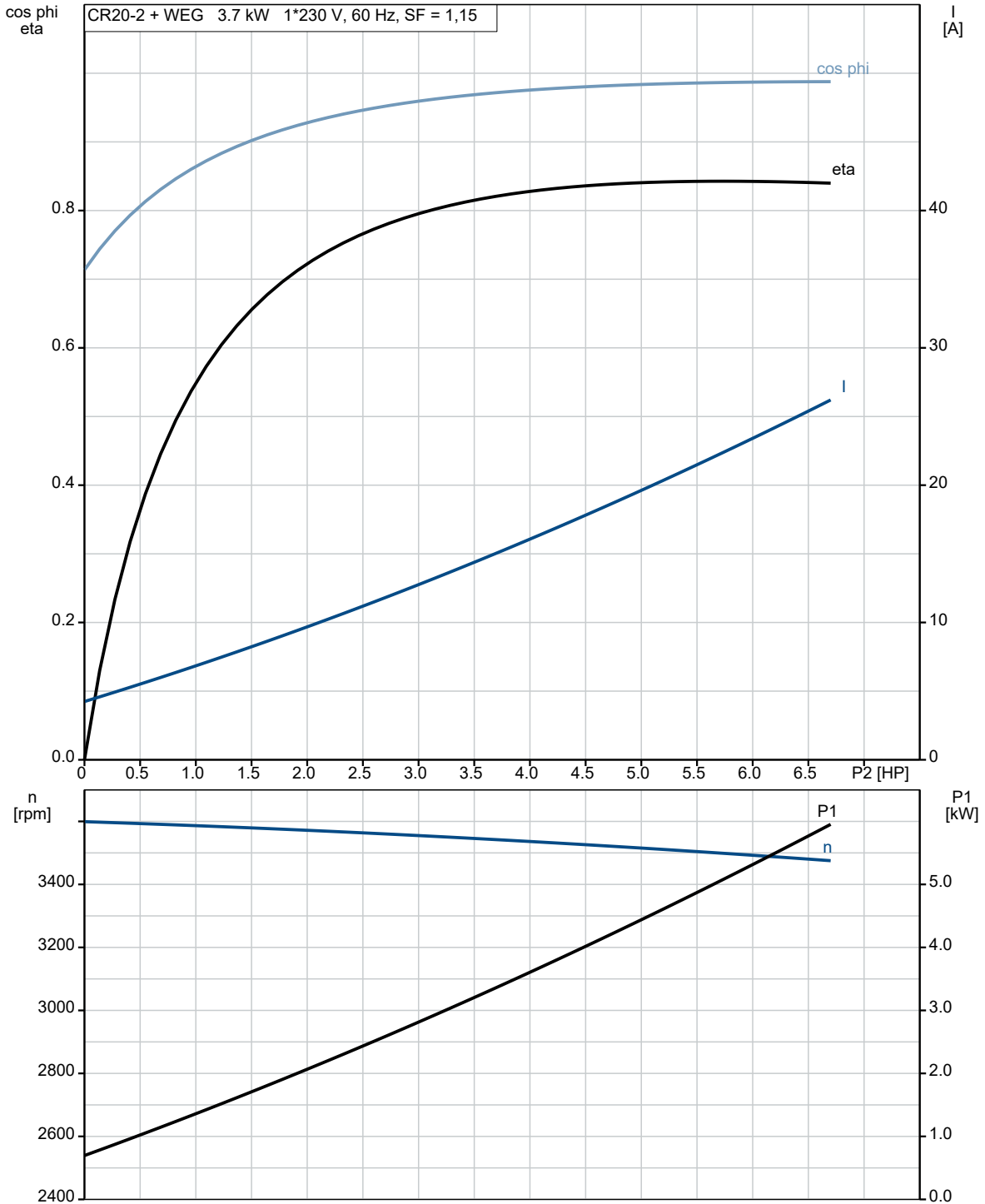



Company name:
Created by:
Phone:

Date: 11/4/2021

99917723 CR 20-2 A-B-A-V-HQQV 60 Hz

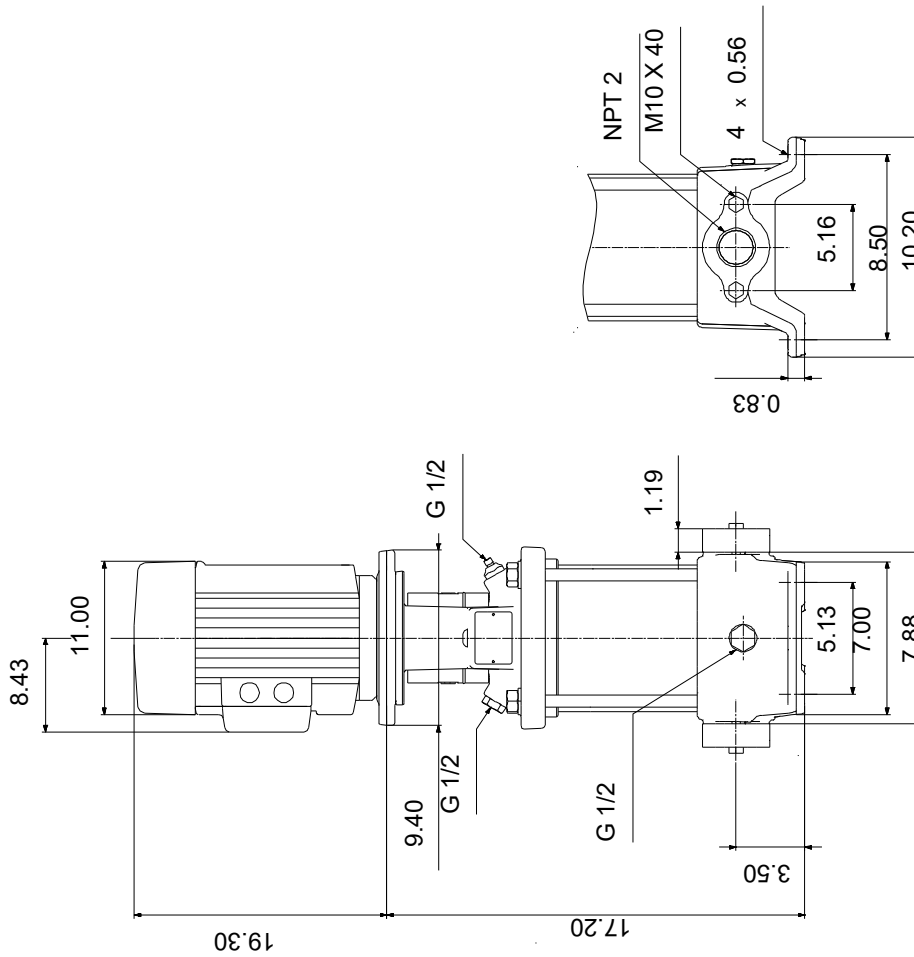

Note! All units are in [in] unless otherwise stated.
Disclaimer: This simplified dimensional drawing does not show all details.

99917723 CR 20-2 A-B-A-V-HQQV 60 Hz

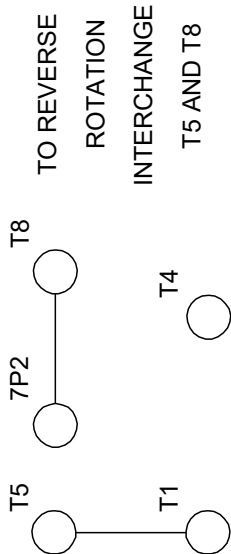
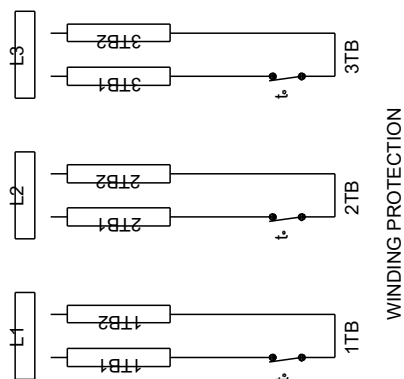

TO REVERSE
ROTATION
INTERCHANGE
T5 AND T8

T1- BLUE	T4- YELLOW	T5- BLACK
T8- RED	7P2- BROWN	

All units are [in] unless otherwise presented.