

# VERTIFLO

*The Vertical Pump Specialists*

## PUMPS FOR INDUSTRY

### CONTENTS:

Introduction & User List

Product Overview

Vertical Process Pumps ..... Series 600

Vertical Sewage Pumps ..... Series 700

**Vertical Sump Pumps ..... Series 800**

Vertical Vortex Pumps ..... Series 900

Vertical Cantilever Pumps ..... Series 1100 and 1200

Horizontal End Suction  
Pumps-Centrifugal ..... Series 1300 and 1400

Horizontal End Suction  
Pumps-Vortex ..... Series 1500 and 1600

Horizontal Self-priming  
Pumps- Centrifugal ..... Series 2100

Engineering Sample Specifications

**VERIFLO MODEL 814**

**Quality Design Features Assure Long, Trouble-Free Service**

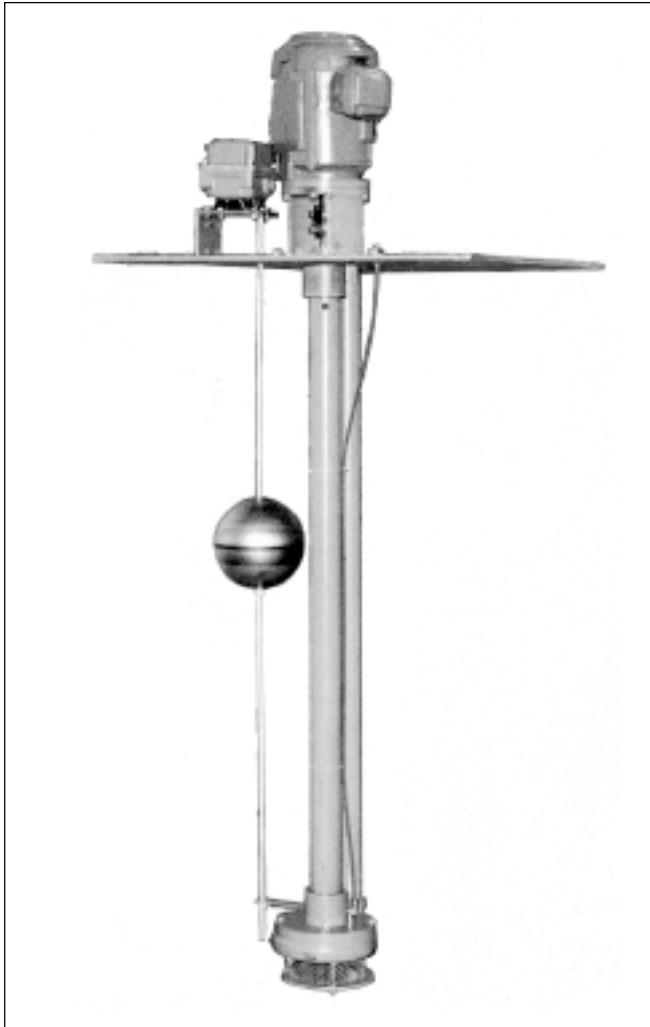

**WIDE RANGE OF APPLICATIONS:**

- Industrial Process
- Pollution Control
- Sump Drainage
- Hazardous, Toxic & Inflammable Liquids
- Clear Liquids
- Condensate
- Corrosive Liquids

**CAPABILITIES:**

- Capacities to 240 GPM
- Heads to 160 Feet TDH
- Temperature to 210° F
- Pit Depths to 7 Feet
- Construction: Cast Iron, Bronze Fitted, 316 Stainless Steel Fitted, All 316 Stainless Steel

800

**CONSTRUCTION:**

**Standard**

- Carbon graphite line-shaft bearings
- Carbon graphite intermediate bearings (Pump built for pit depth over 5'-0")(4'-0" @ 3500 RPM)
- High thrust, angular contact ball bearing
- Product lubricated line shaft bearings
- 316 stainless steel shaft
- Round or square cover plate
- Pump setting increments of 1'-0" for sump depths up through 7'-0"
- 316 stainless steel float
- Standard C face motors

**Options**

- Stainless steel fitted, bronze fitted or all stainless steel construction
- External flush for bearing lubrication
- Various float switch enclosures
- Various liquid level controls
- High water alarm
- Alarm bells and horns
- Control Panels

## 1. Motor Support

Assures positive alignment of motor and pump shaft with register fit. Normal thrust, vertical NEMA C face motor standard

## 2. Flexible Coupling

## 3. External Impeller Adjustment

High performance maintained without dismantling pump

## 4. Thrust Bearing

High thrust angular contact bearing. Permanently lubricated for life

## 5. Gas Tight Column Closure

Prevents vapor from escaping from column

## 6. Cover Plate

17 1/2" round or square

## 7. Column Pipe

Schedule 40 steel

## 8. Intermediate Bearing Assembly

Furnished as standard on pumps built for pit depths greater than 5'-0" at 1750 RPM and 4'-0" at 3500 RPM

## 9. Shafting

Accurately machined 316 stainless steel, 7/8" diameter to assure minimum deflection

## 10. Bearings

Carbon graphite - Product lubrication is standard. Designed for clean, non-abrasive liquids.

## 11. Impeller

Semi-open design for wide range of industrial applications, secured to shaft with taper fit by thread

## 12. Casing

Heavy walled casting

## 13. Suction Strainer

Cast iron

## 14. Discharge Pipe

Schedule 40, threaded; flanged connection optional

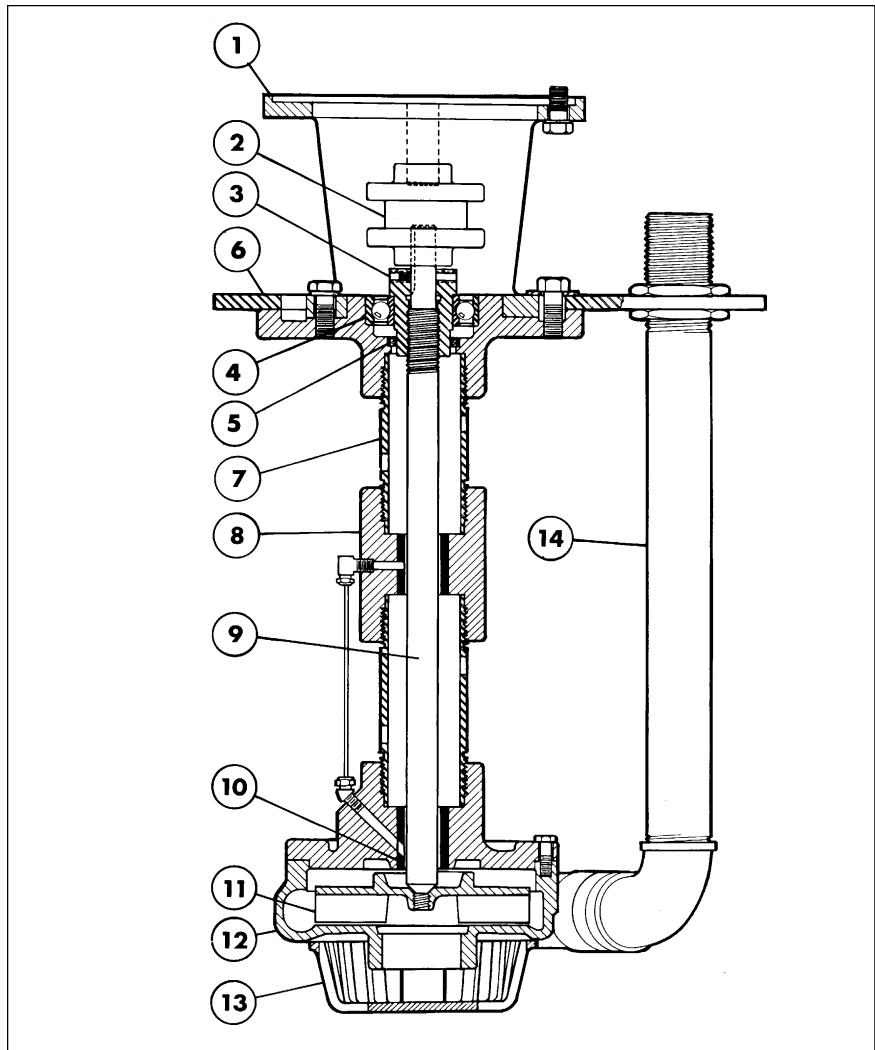

## Materials of Construction

Part Description	Standard Fitted	316 Stainless Fitted	All 316 Stainless
Motor Support	Cast Iron	Cast Iron	Cast Iron
Thrust Bearing Housing	Class 30	Class 30	Class 30
Shaft	Stainless Steel AISI-316	Stainless Steel AISI-316	Stainless Steel AISI-316
Column	Steel ASTM-A53	Steel ASTM-A53	Stainless Steel AISI-316
Bearing Housing	Cast Iron Class 30	Cast Iron Class 30	Stainless Steel AISI-316
Guide Bearings	Carbon Graphite	Carbon Graphite	Carbon Graphite
Impeller	Cast Iron Class 30	Stainless Steel AISI-316	Stainless Steel AISI-316
Casing	Cast Iron Class 30	Cast Iron Class 30	Stainless Steel AISI-316
Gasket	Vellumoid	Vellumoid	NA 700
Strainer	Cast iron Class 30	Cast iron Class 30	Stainless Steel AISI-316
Discharge Elbow	Cast Iron AISI-B164	Cast Iron AISI-B164	Stainless Steel AISI-316
Discharge Pipe	Steel ASTM-A53	Steel ASTM-A53	Stainless Steel AISI-316
Cover Plate	Steel HRS	Steel HRS	Steel HRS
Lip Seal	Nitrile	Nitrile	Nitrile

# VERTIFLO PUMP COMPANY Performance Curves

## Series 800 / Model 814 Size 1 1/2 X 1 X 6

1750 RPM

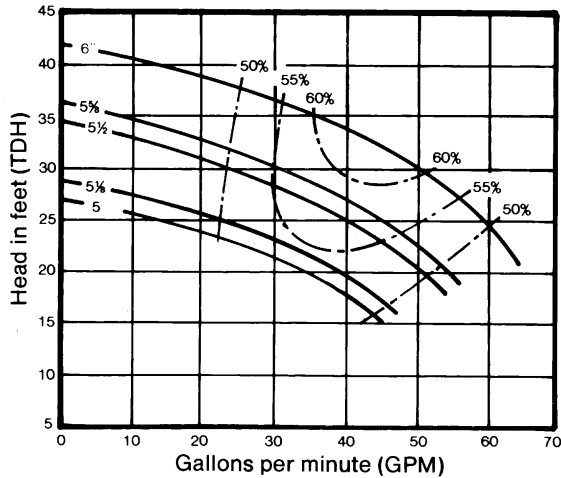

HP	SF	DIA
3/4	1.15	6
	1.00	6
1/2	1.15	5 5/8
	1.00	5 1/2
1/3	1.15	5 1/8
	1.00	5

3500 RPM

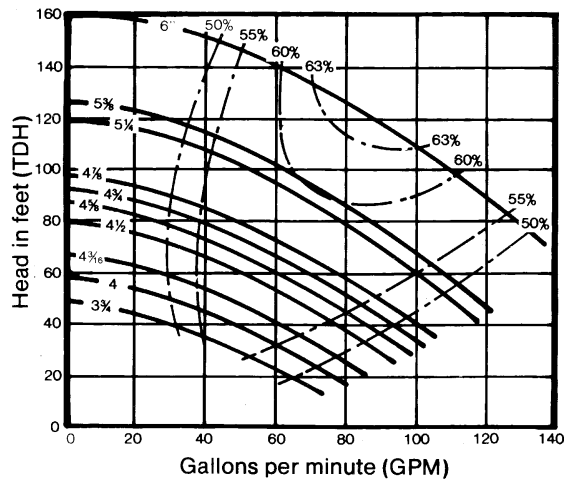

HP	SF	DIA	HP	SF	DIA
5	1.15	6	1 1/2	1.15	4 5/8
	1.00	6		1.00	4 1/2
3	1.15	5 3/8	1	1.15	4 3/16
	1.00	5 1/4		1.00	4
2	1.15	4 7/8			
	1.00	4 3/4			

## Series 800 / Model 814 Size 2 X 1 1/2 X 6

1750 RPM

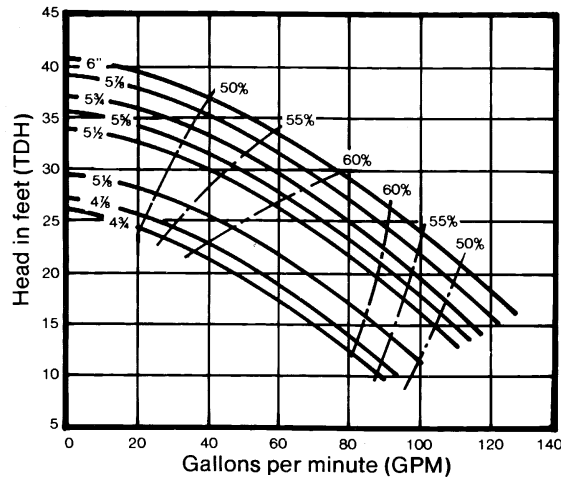

HP	SF	DIA	HP	SF	DIA
1 1/2	1.15	6	3/4	1.15	5 5/8
	1.00	6		1.00	5 1/2
1	1.15	5 7/8	1/2	1.15	5 1/8
	1.00	4 7/8		1.00	4 7/8

3500 RPM

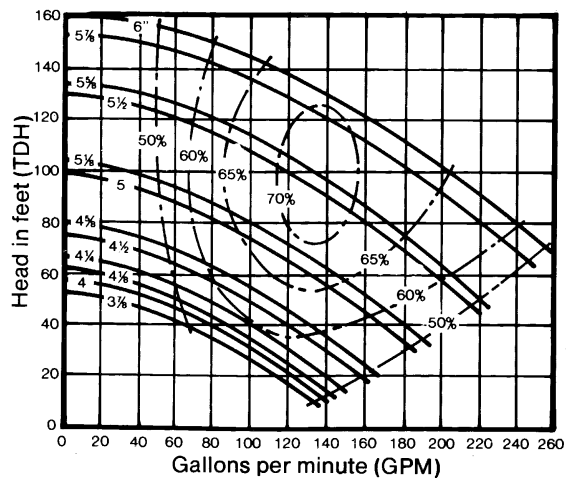

HP	SF	DIA	HP	SF	DIA
7 1/2	1.15	6	2	1.15	4 5/8
	1.00	5 7/8		1.00	4 1/2
5	1.15	5 5/8	1 1/2	1.15	4 1/4
	1.00	5 1/2		1.00	4 1/8
3	1.15	5 1/8	1	1.15	4
	1.00	5		1.00	3 7/8

Performance at Casing Discharge Flange

Curves Show Performance with Liquid Having Specific Gravity 1.0 Viscosity • 30 SSU

CUSTOMER \_\_\_\_\_ CUSTOMER NO. \_\_\_\_\_

PROJECT \_\_\_\_\_

ENGINEER \_\_\_\_\_

CONTRACTOR \_\_\_\_\_

CONDITIONS: \_\_\_\_\_ GPM \_\_\_\_\_ TDH \_\_\_\_\_ HP \_\_\_\_\_ EFF% \_\_\_\_\_ IMP. DIA \_\_\_\_\_

# VERTIFLO PUMP COMPANY Dimensions

## 814 Simplex Sump Pump

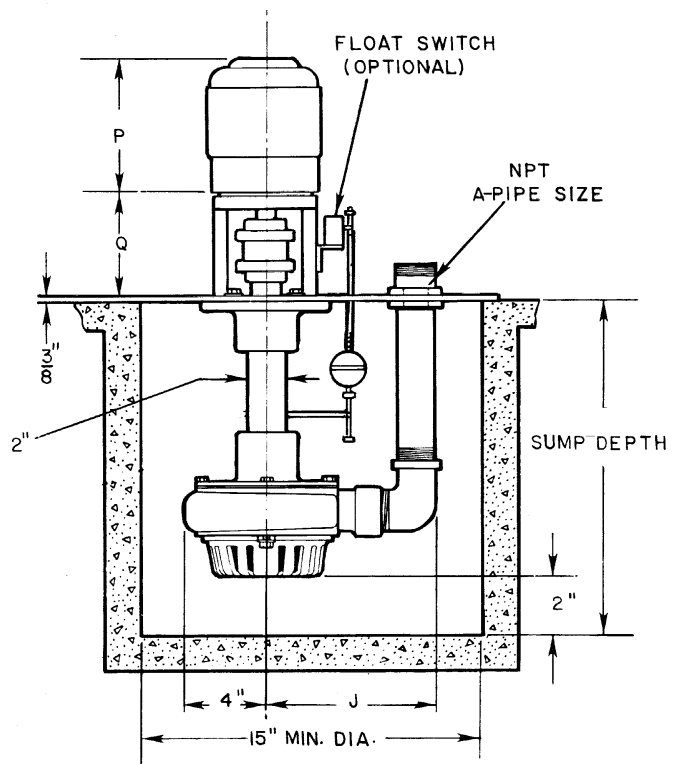
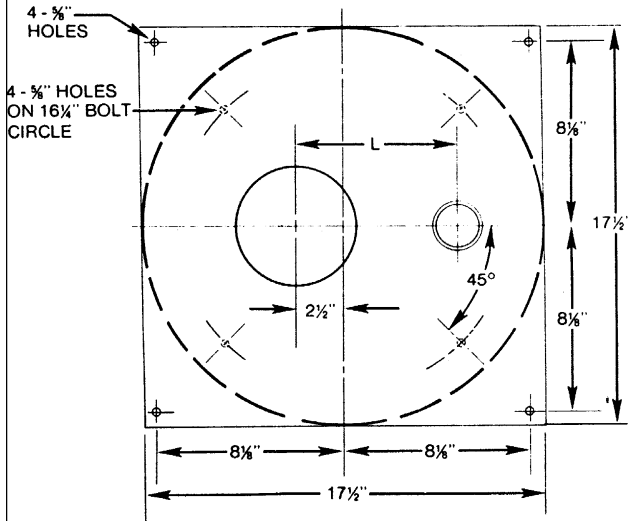

### PUMP DATA

SIZE	A	C	J	L
1 1/2 x 1 x 6	1	2 to 12 Feet*	7 1/2	6 1/2
	1 1/2		8 1/4	7
2 x 1 1/2 x 6	1 1/2	2 to 12 Feet*	8 1/2	7 1/4
	2		9 1/4	7 3/4

### MOTOR DATA

FRAME	P	Q
56 C	12 1/8	5 5/8
143 TC - 145TC	12 1/4	5 5/8
182TC - 184TC	15 7/16	6 5/8
213TC - 215TC	16 1/16	6 5/8

\* Sump Depth is in 1 Foot Increments

Not for construction unless certified, some dimensions may vary  $\pm 1/2"$ . Pump Construction: \_\_\_\_\_

CUSTOMER \_\_\_\_\_ CUSTOMER NO. \_\_\_\_\_  
 PROJECT \_\_\_\_\_ SERIAL NO. \_\_\_\_\_  
 ENGINEER \_\_\_\_\_ LOCATION \_\_\_\_\_  
 CONTRACTOR \_\_\_\_\_  
 PUMP Model Size Curve No. GPM Head SP. GR. @Temp. Pump Length Plate  
 DATA \_\_\_\_\_  
 MOTOR Mfgr. HP RPM Volt-Phase-Cycle Frame ENC. Furnished by Mounted by  
 DATA \_\_\_\_\_  
 Shop Order \_\_\_\_\_ Certified by \_\_\_\_\_ Date \_\_\_\_\_

## 814 Duplex Sump Pump

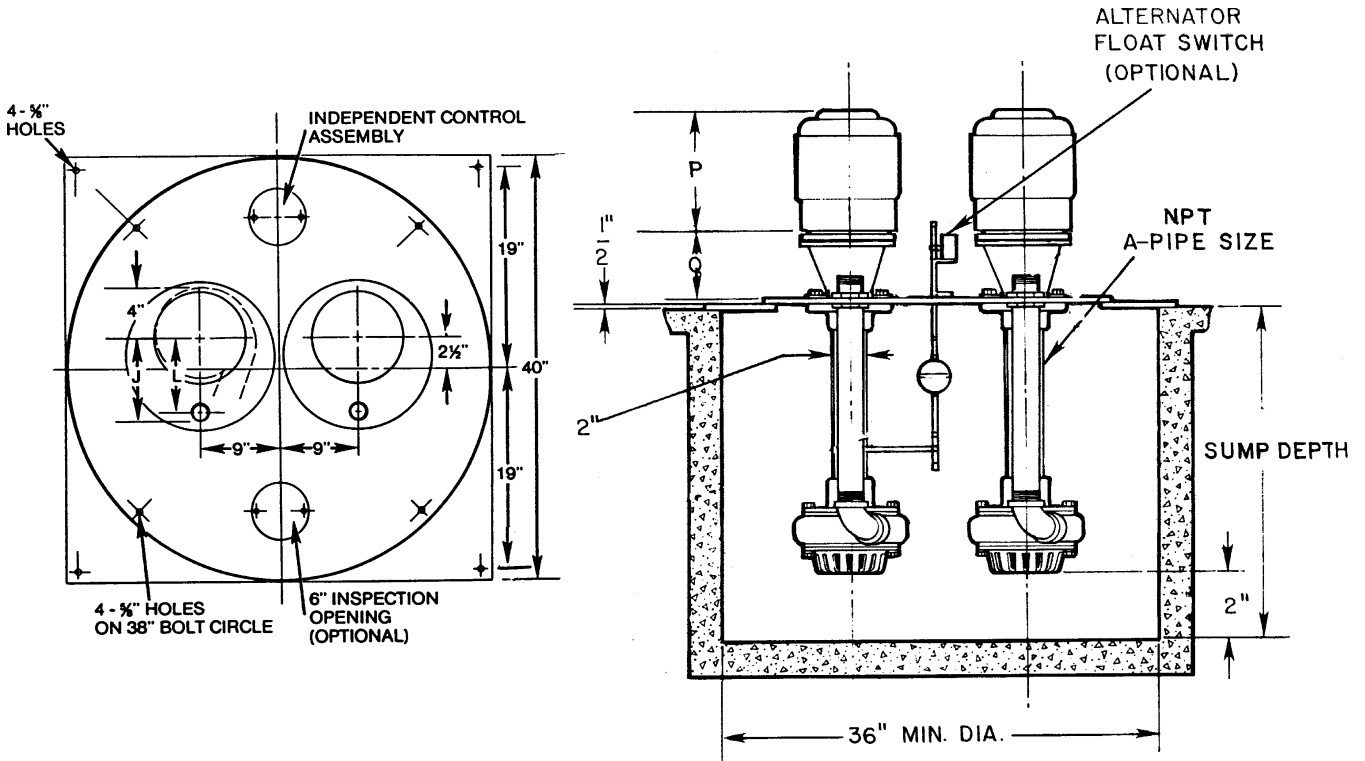

### PUMP DATA

SIZE	A	C	J	L
1½ x 1 x 6	1	2 to 12 Feet*	7½	6½
	1½		8¼	7
2 x 1½ x 6	1½	2 to 12 Feet*	8½	7¼
	2		9¼	7¾

\* Sump Depth is in 1 Foot Increments

### MOTOR DATA

FRAME	P	Q
56 C	12⅞	5⅝
143 TC - 145TC	12¼	5⅝
182TC - 184TC	15⅞	6⅝
213TC - 215TC	16⅞	6⅝

Not for construction unless certified, some dimensions may vary ± 1/2". Pump Construction: \_\_\_\_\_

CUSTOMER \_\_\_\_\_ CUSTOMER NO. \_\_\_\_\_  
 PROJECT \_\_\_\_\_ SERIAL NO. \_\_\_\_\_  
 ENGINEER \_\_\_\_\_ LOCATION \_\_\_\_\_  
 CONTRACTOR \_\_\_\_\_  
 PUMP Model Size Curve No. GPM Head SP. GR. @Temp. Pump Length Plate  
 DATA \_\_\_\_\_  
 MOTOR Mfg. HP RPM Volt-Phase-Cycle Frame ENC. Furnished by Mounted by  
 DATA \_\_\_\_\_  
 Shop Order \_\_\_\_\_ Certified by \_\_\_\_\_ Date \_\_\_\_\_



**VERIFLO SERIES 800**

**Quality Design Features Assure Long, Trouble-Free Service**



Series 800 Duplex

**WIDE RANGE OF APPLICATIONS:**

- Industrial Process
- Pollution Control
- Sump Drainage
- Flood Control
- Hazardous, Toxic & Inflammable Liquids
- Clear Liquids
- Condensate
- Corrosive Liquids
- Acids

**CAPABILITIES:**

- Capacities to 3000 GPM
- Heads to 230 Feet TDH
- Temperature to 350° F
- Pit Depths to 26 Feet
- Construction: Cast Iron, 316 Stainless Steel Fitted, All 316 Stainless Steel, Alloy 20, Hastelloy, CD4MC<sub>u</sub>

**CONSTRUCTION:**

**Standard**

- Bronze bottom line shaft bearings
- Bronze intermediate bearings (pump built for pit depths over 6'-0")
- Semi-open impeller with balancing ring and wiping vanes
- High thrust, angular contact ball bearing
- Grease lubricated pump and line shaft bearings
- 416 stainless steel shaft
- Round, square or oval cover plates
- External impeller adjustment
- Pump setting increments of 1'-0" for pit depths up to 26'-0"
- Flanged discharge on all casings
- Standard C face motors

**Options**

- Stainless steel fitted, All stainless steel, Alloy 20, Hastelloy construction
- Various line shaft bearing designs
- 316 stainless steel shafting
- Cover plate with manhole, vent or special openings
- Vapor-proof construction
- Various float switch enclosures
- Various liquid level controls
- High water alarm
- Alarm bells and horns
- 316 stainless steel float rod
- 316 stainless steel float
- Below plate discharge "T"
- Special pump lengths



Series 800 Simplex



## 1. Motor Support

Assures positive alignment of motor and pump shaft with register fit. Normal thrust, vertical NEMA C face motor standard

## 2. Flexible Coupling

## 3. External Impeller Adjustment

High performance maintained without dismantling pump

## 4. Thrust Bearing

High thrust angular contact bearing. Moisture-proof enclosure, (2) grease seals, purge-type grease lubrication

## 5. Gas Tight Column Closure

Lip seal, grease lubricated

## 6. Cover Plate

Designed for specific unit. Optional sizes and gas-tight construction available

## 7. Column Pipe

Schedule 40 steel with welded flanges

## 8. Positive Machined Fits

Machined registered fits of column, bearing housing and casing

## 9. Intermediate Bearing Assembly

Optional designs for special applications. Furnished as standard on pumps built for pit depths greater than 6'-0"

## 10. Shafting

Accurately machined 416 stainless steel, 1 1/4", 1 1/2" or 2" diameter to assure minimum deflection

## 11. Pump Bearing Assembly

Heavy construction designed for maximum bearing loadings. Optional designs available

## 12. Bearings

Various materials available to suit most applications

## 13. Choker Ring

Restricts entrance of abrasives and solids into bottom bearing

## 14. Impeller

Semi-open design with balancing ring & wiping vanes for wide range of industrial applications, secured to shaft with taper fit by woodruff key, castellated nut, washer and cotter pin

## 15. Casing

Flanged suction and discharge all sizes. Double volute design on all 4X3X10 and larger sizes

## 16. Suction Strainer

304 stainless steel

## 17. Discharge Pipe

1"-2 1/2" threaded, 3" and larger flanged. Below plate "T"-type discharge available

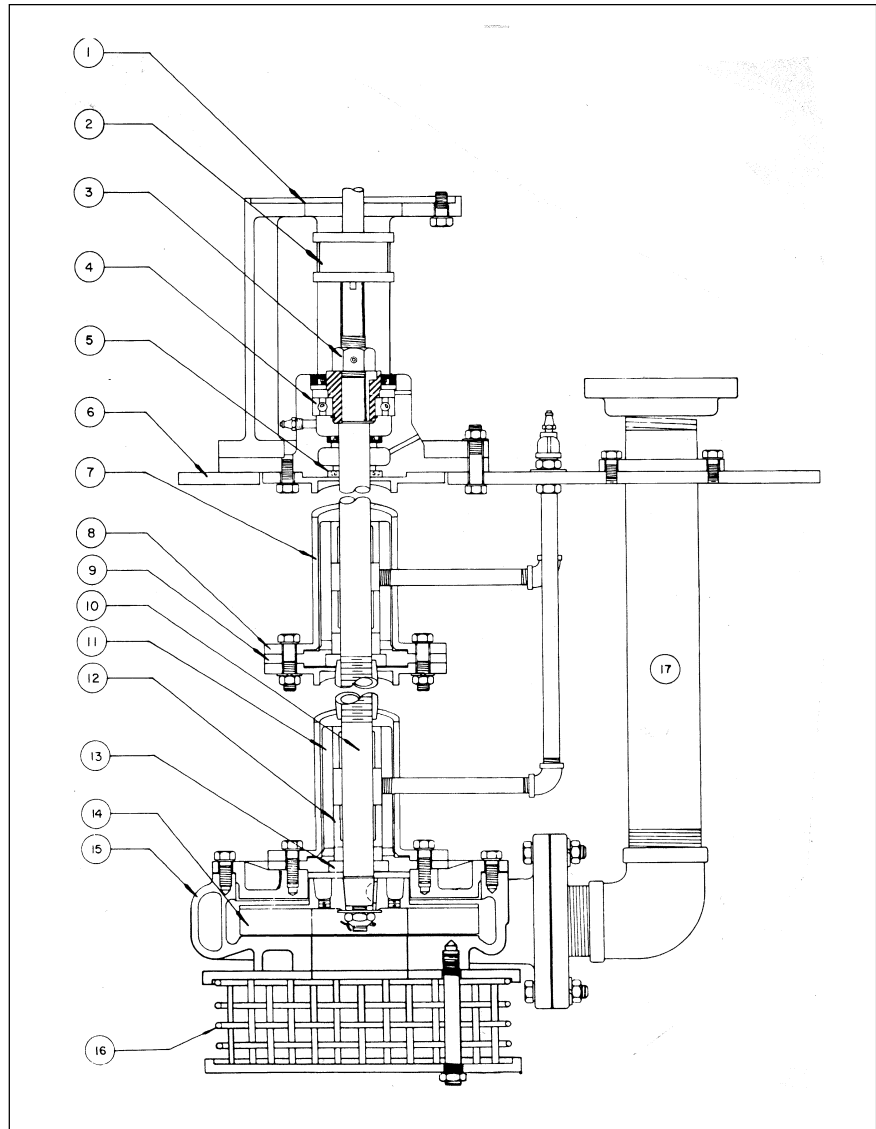

## Standard Line Shaft Bearing Assemblies

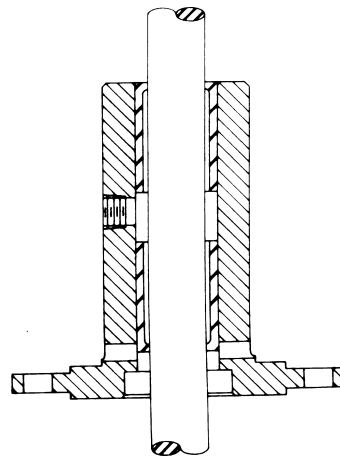

### Lower Bearing Assembly

The standard pump bearing assembly consists of choker ring and (2) guide bearing bushings compatible with the liquid. Standard bronze bearings furnished with grease lubrication. Optional: carbon graphite, rubber, Teflon\*

### Intermediate Bearing Assembly

The standard intermediate assembly consists of (2) guide bearings compatible with the liquid and is standard when pit depth exceeds 6 feet. Standard bronze bearings furnished with grease lubrication. Optional: carbon graphite, rubber, Teflon\*

\*E.I DuPont registered <sup>TM</sup>

Part Description	Standard Fitted	316 Stainless Fitted	All 316 Stainless	All Alloy 20
Motor Support, Thrust Bearing Housing	Cast Iron Class 30	Cast Iron Class 30	Cast Iron Class 30	Cast Iron Class 30
Shaft	Stainless Steel AISI-416	Stainless Steel AISI-316	Stainless Steel AISI-316	Alloy 20
Column	Steel ASTM-A53	Steel ASTM-A53	Stainless Steel AISI-316	Alloy 20
Bearing Housing	Cast Iron Class 30	Cast Iron Class 30	Stainless Steel AISI-316	Alloy 20
Guide Bearings	Bronze SAE 660	Bronze SAE 660	Graphite	Graphite
Casing Adaptor	Cast Iron Class 30	Cast Iron Class 30	Stainless Steel AISI-316	Alloy 20
Impeller	Cast Iron Class 30	Stainless Steel AISI-316	Stainless Steel AISI-316	Alloy 20
Impeller Trim	Stainless Steel AISI-316	Stainless Steel AISI-316	Stainless Steel AISI-316	Alloy 20
Casing	Cast Iron Class 30	Cast Iron Class 30	Stainless Steel AISI-316	Alloy 20
Gasket	Vellumoid	Vellumoid	NA 700	NA 700
Strainer Plate	Cast Iron Class 30	Cast Iron Class 30	Stainless Steel AISI-316	Alloy 20
Strainer Basket	Stainless Steel AISI-304	Stainless Steel AISI-304	Stainless Steel AISI-316	Alloy 20
Discharge Elbow	Cast Iron AISI-B164	Cast Iron AISI-B164	Stainless Steel AISI-316	Alloy 20
Discharge Pipe	Steel ASTM-A53	Steel ASTM-A53	Stainless Steel AISI-316	Alloy 20
Cover Plate	Steel HRS	Steel HRS	Steel HRS	Steel HRS
Bearing Adaptor	Steel AISI-12L14	Steel AISI-12L14	Steel AISI-12L14	Steel AISI-12L14
Adjusting Nut	Steel ASTM-307	Steel ASTM-307	Steel ASTM-307	Steel ASTM-307
Lip Seal	Nitrile	Nitrile	Nitrile	Nitrile

**Alternate Line Shaft Bearing Assemblies**

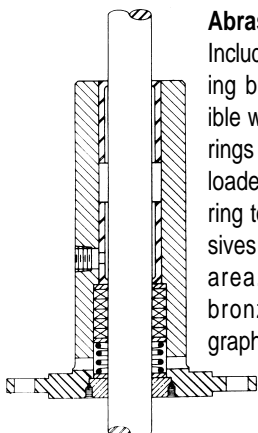

**Abrasive Service - 1**  
Includes (2) guide bearing bushings compatible with the liquid, (5) rings of packing spring loaded and a choker ring to eliminate abrasives from the bearing area. Optional are bronze or carbon graphite.

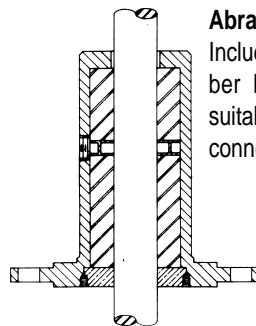

**Abrasive Service - 2**  
Includes (2) cutless rubber bearing bushings suitable for water flush connection.

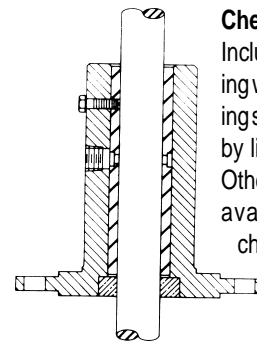

**Chemical Service**  
Includes (1) Teflon\* bearing w/stainless steel locking screws and lubricated by liquid being pumped. Other bearing materials available for special chemical services.

NOTE: Bearing assemblies shown are typical for most pumping services. Unusual or severe services may necessitate changes in assembly design.

\*E.I DuPont registered TM

# VERTIFLO PUMP COMPANY Performance Curves

Curve PV-1525

Series 800  
 Size 3 X 2 1/2 X 7  
 RPM 1750  
 Max Sphere 1

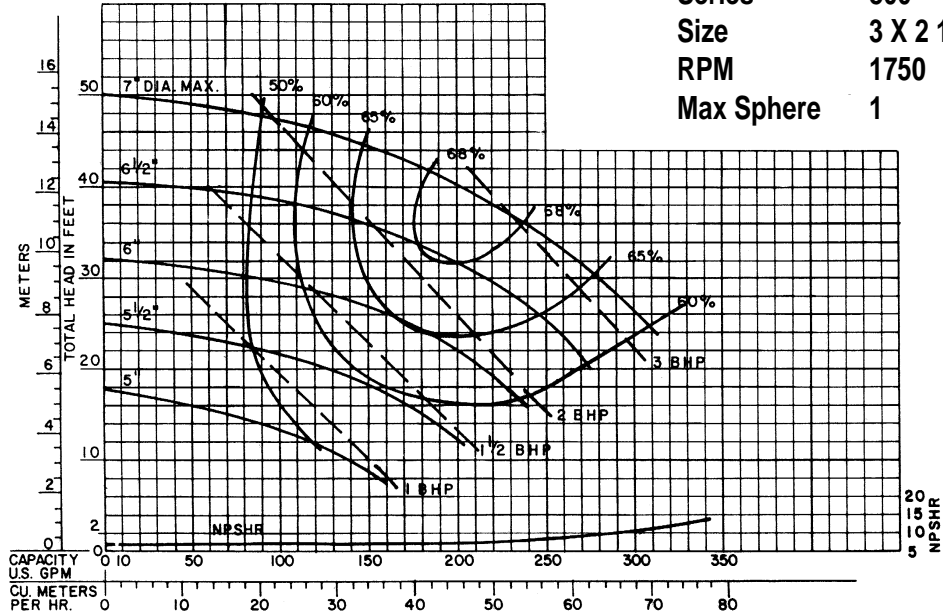

Curve RV-1525

Series 800  
 Size 3 X 2 1/2 X 7  
 RPM 1150  
 Max Sphere 1

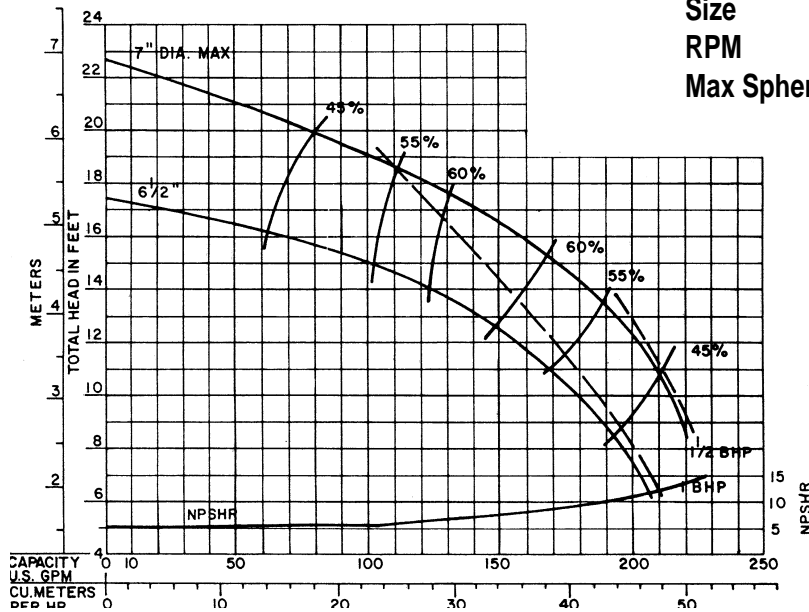

Performance at Casing Discharge Flange

Curves Show Performance with Liquid Having Specific Gravity 1.0 Viscosity • 30 SSU

CUSTOMER \_\_\_\_\_ CUSTOMER NO. \_\_\_\_\_

PROJECT \_\_\_\_\_

ENGINEER \_\_\_\_\_

CONTRACTOR \_\_\_\_\_

CONDITIONS: \_\_\_\_\_ GPM \_\_\_\_\_ TDH \_\_\_\_\_ HP \_\_\_\_\_ EFF% \_\_\_\_\_ IMP. DIA \_\_\_\_\_

# VERTIFLO PUMP COMPANY Performance Curves

Curve AS-1610

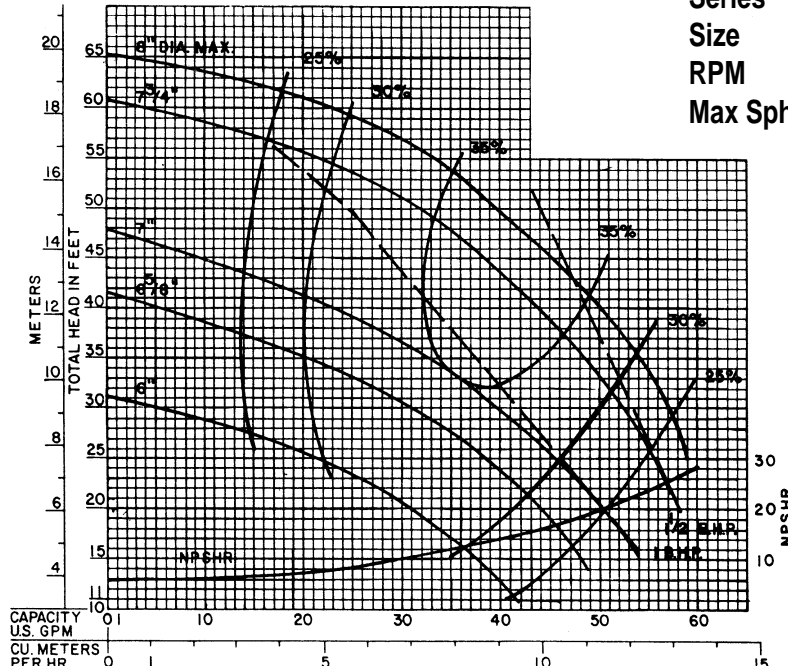

Series 800  
 Size 1 1/2 X 1 X 8  
 RPM 1750  
 Max Sphere 1/4

Curve BS-1610

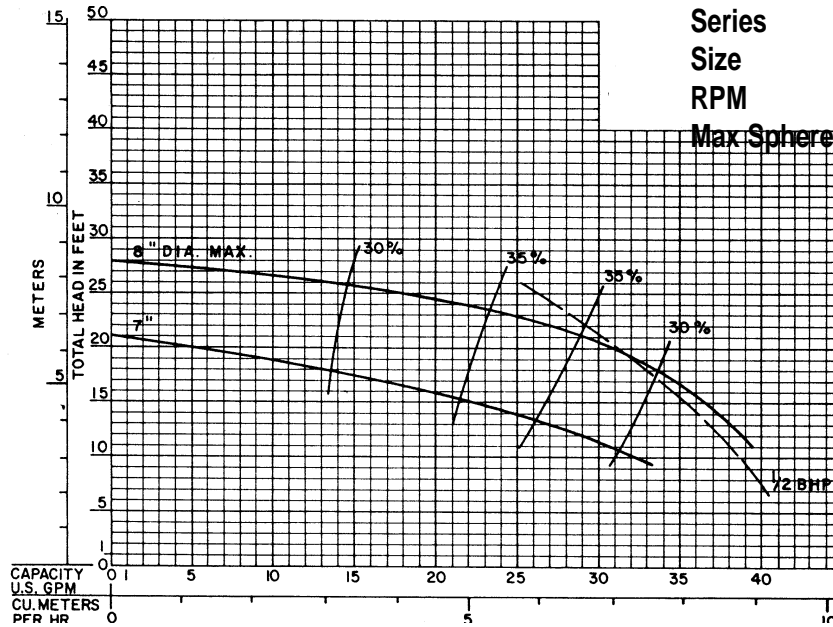

Series 800  
 Size 1 1/2 X 1 X 8  
 RPM 1150  
 Max Sphere 1/4

800

Performance at Casing Discharge Flange  
 Curves Show Performance with Liquid Having Specific Gravity 1.0 Viscosity • 30 SSU

CUSTOMER \_\_\_\_\_ CUSTOMER NO. \_\_\_\_\_  
 PROJECT \_\_\_\_\_  
 ENGINEER \_\_\_\_\_  
 CONTRACTOR \_\_\_\_\_  
 CONDITIONS: \_\_\_\_\_ GPM \_\_\_\_\_ TDH \_\_\_\_\_ HP \_\_\_\_\_ EFF% \_\_\_\_\_ IMP. DIA \_\_\_\_\_

# VERTIFLO PUMP COMPANY Performance Curves

**Curve AS-1612**

Series 800  
 Size 1 1/2 X 1 1/4 X 8  
 RPM 1750  
 Max Sphere 5/16

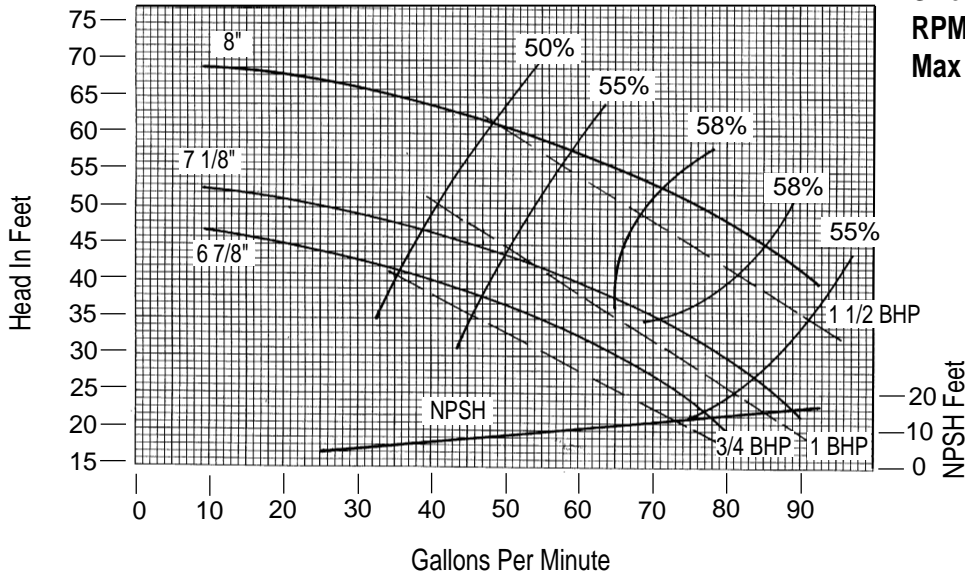

**Curve BS-1612**

Series 800  
 Size 1 1/2 X 1 1/4 X 8  
 RPM 1150  
 Max Sphere 5/16

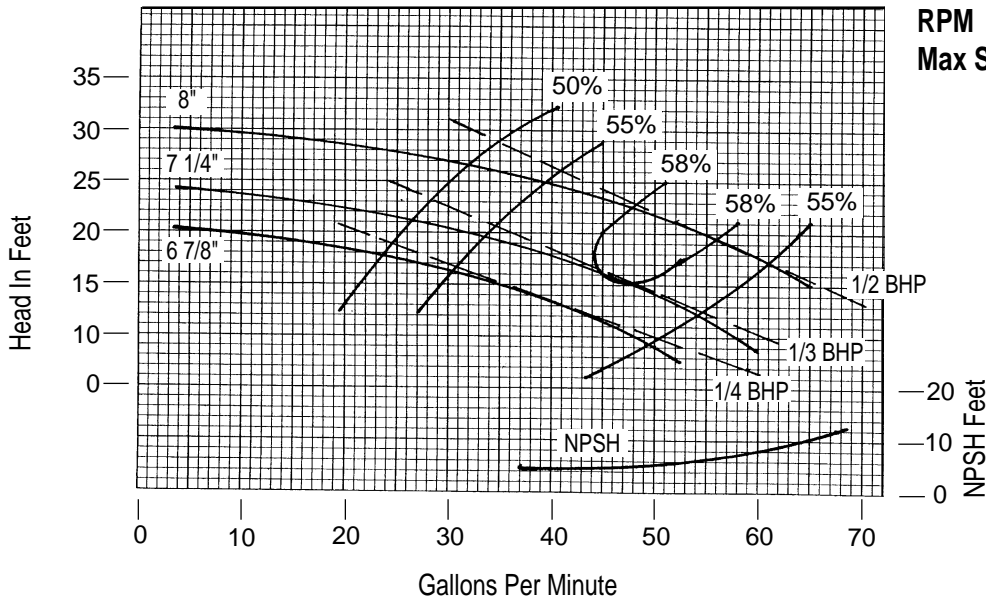

Performance at Casing Discharge Flange

Curves Show Performance with Liquid Having Specific Gravity 1.0 Viscosity • 30 SSU

CUSTOMER \_\_\_\_\_ CUSTOMER NO. \_\_\_\_\_

PROJECT \_\_\_\_\_

ENGINEER \_\_\_\_\_

CONTRACTOR \_\_\_\_\_

CONDITIONS: \_\_\_\_\_ GPM \_\_\_\_\_ TDH \_\_\_\_\_ HP \_\_\_\_\_ EFF% \_\_\_\_\_ IMP. DIA \_\_\_\_\_

# VERTIFLO PUMP COMPANY Performance Curves

Curve BS-1615

Series 800  
 Size 2 X 1 1/2 X 8  
 RPM 1750  
 Max Sphere 7/16

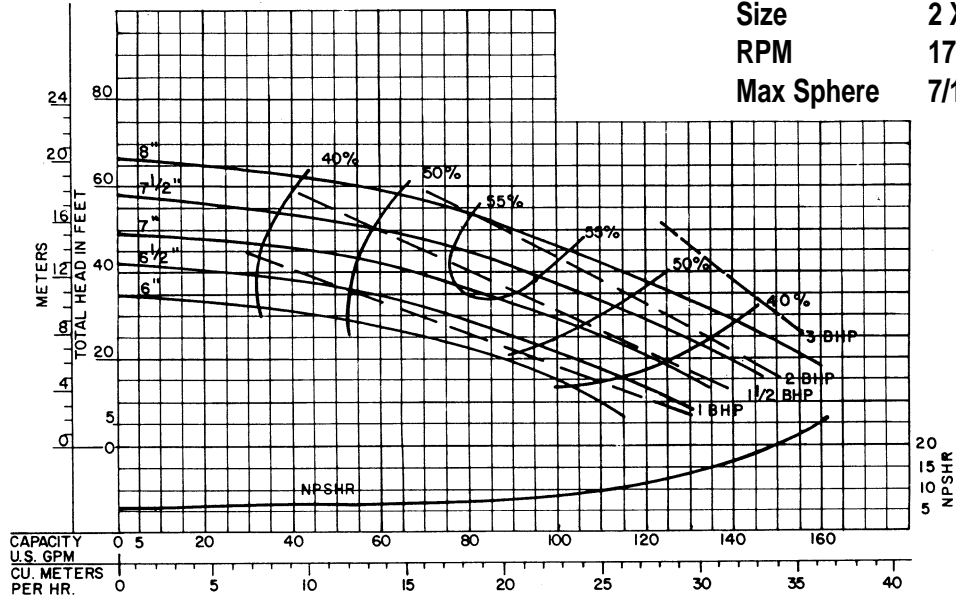

Curve CS-1615

Series 800  
 Size 2 X 1 1/2 X 8  
 RPM 1150  
 Max Sphere 7/16

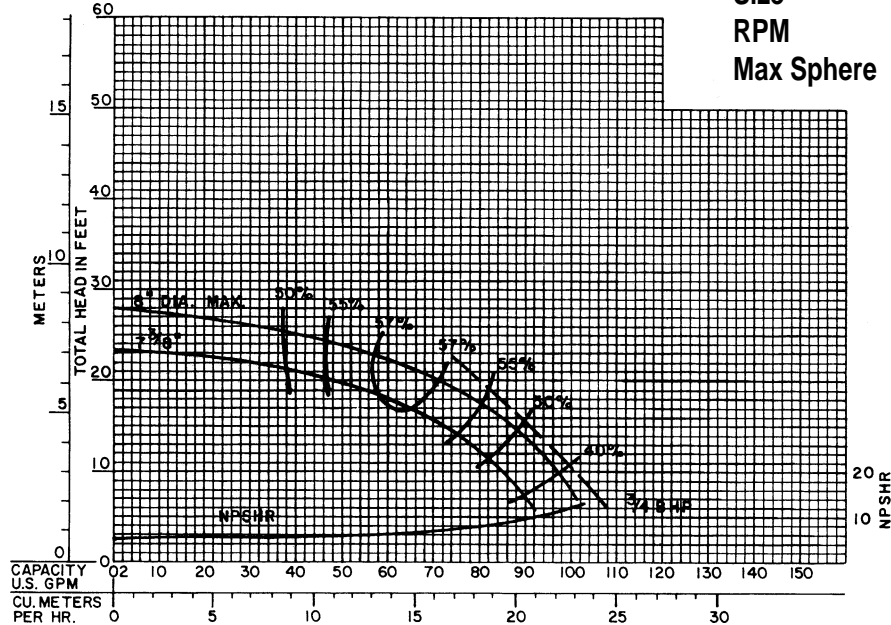

Performance at Casing Discharge Flange

Curves Show Performance with Liquid Having Specific Gravity 1.0 Viscosity • 30 SSU

CUSTOMER \_\_\_\_\_ CUSTOMER NO. \_\_\_\_\_

PROJECT \_\_\_\_\_

ENGINEER \_\_\_\_\_

CONTRACTOR \_\_\_\_\_

CONDITIONS: \_\_\_\_\_ GPM \_\_\_\_\_ TDH \_\_\_\_\_ HP \_\_\_\_\_ EFF% \_\_\_\_\_ IMP. DIA \_\_\_\_\_

800

# VERTIFLO PUMP COMPANY Performance Curves

Curve CS-1620

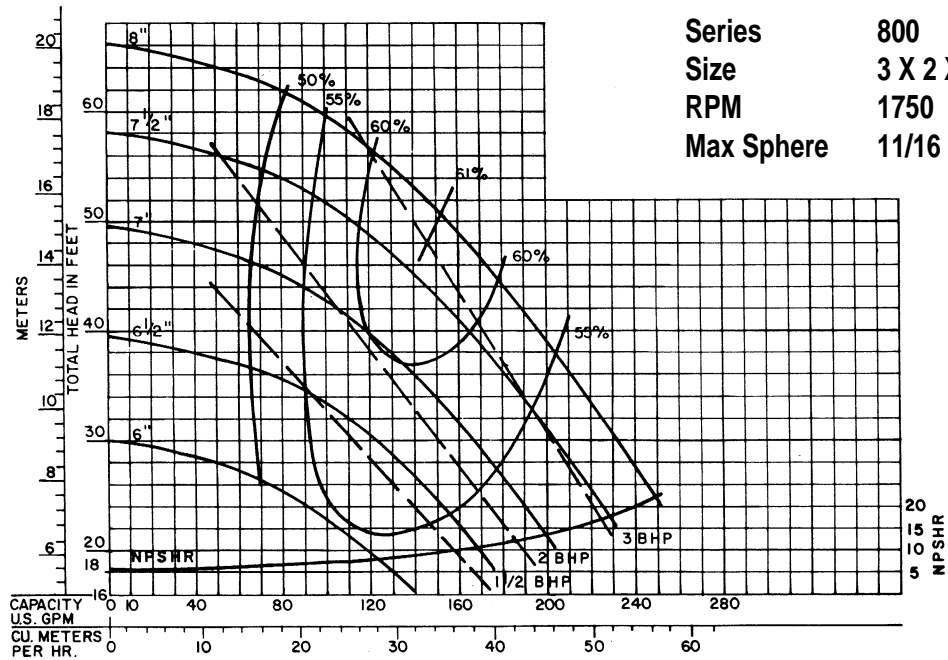

Curve DS-1620

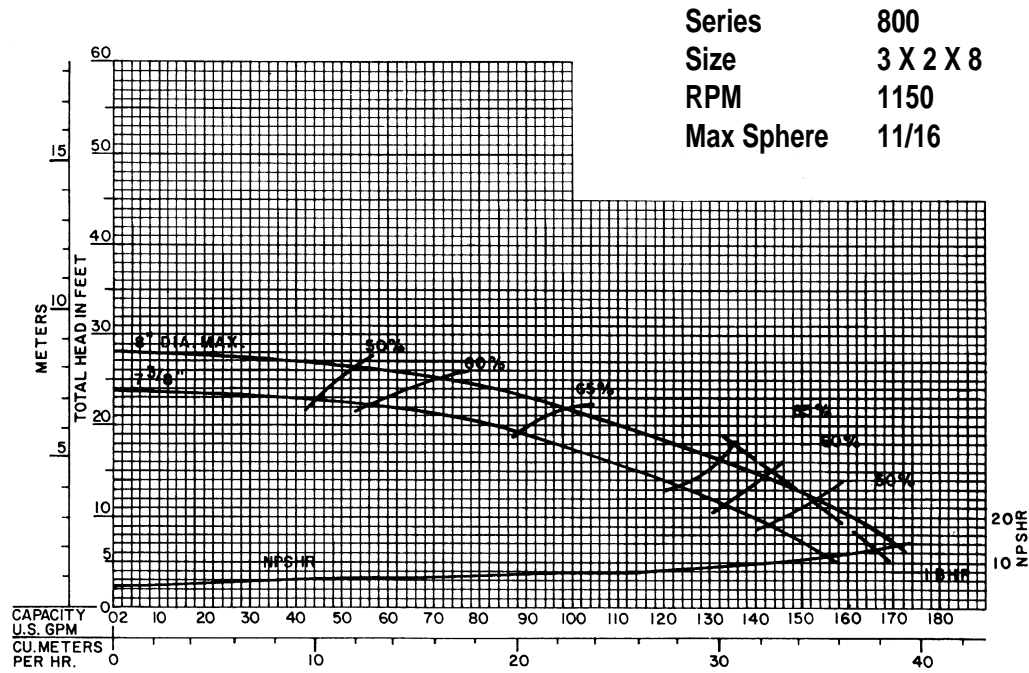

Performance at Casing Discharge Flange

Curves Show Performance with Liquid Having Specific Gravity 1.0 Viscosity • 30 SSU

CUSTOMER \_\_\_\_\_ CUSTOMER NO. \_\_\_\_\_

PROJECT \_\_\_\_\_

ENGINEER \_\_\_\_\_

CONTRACTOR \_\_\_\_\_

CONDITIONS: \_\_\_\_\_ GPM \_\_\_\_\_ TDH \_\_\_\_\_ HP \_\_\_\_\_ EFF% \_\_\_\_\_ IMP. DIA \_\_\_\_\_

# VERTIFLO PUMP COMPANY Performance Curves

Curve CS-1630

Series 800  
 Size 4 X 3 X 8  
 RPM 1750  
 Max Sphere 1 3/16

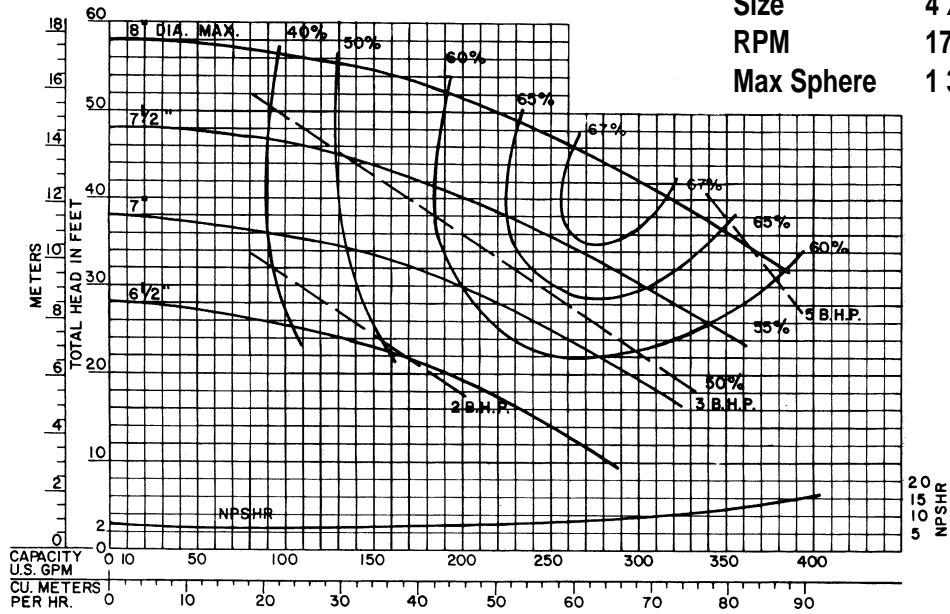

Curve DS-1630

Series 800  
 Size 4 X 3 X 8  
 RPM 1150  
 Max Sphere 1 3/16

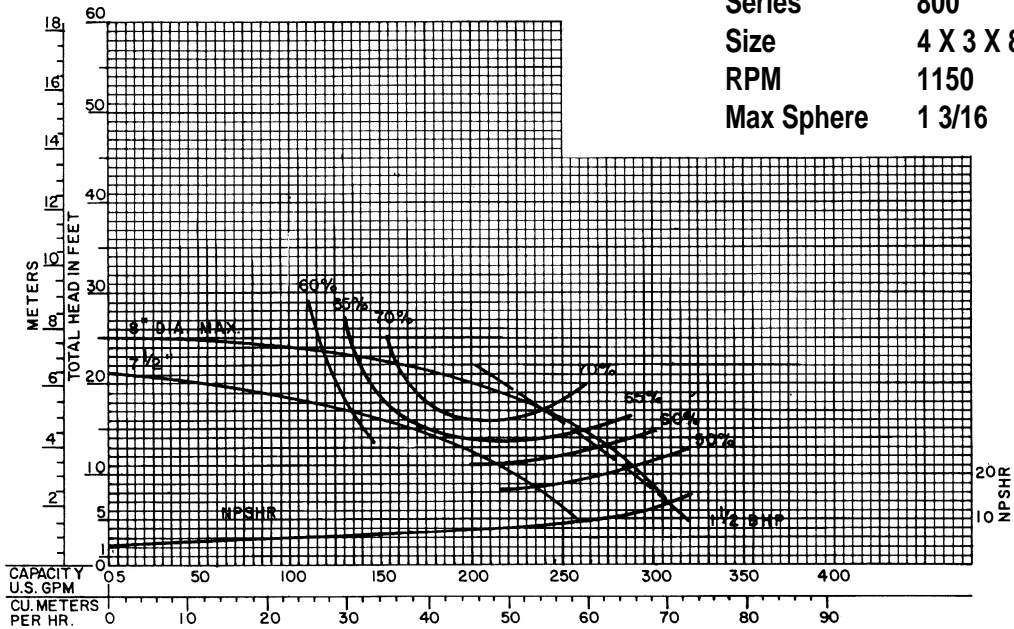

Performance at Casing Discharge Flange  
 Curves Show Performance with Liquid Having Specific Gravity 1.0 Viscosity • 30 SSU

CUSTOMER \_\_\_\_\_ CUSTOMER NO. \_\_\_\_\_  
 PROJECT \_\_\_\_\_  
 ENGINEER \_\_\_\_\_  
 CONTRACTOR \_\_\_\_\_  
 CONDITIONS: \_\_\_\_\_ GPM \_\_\_\_\_ TDH \_\_\_\_\_ HP \_\_\_\_\_ EFF% \_\_\_\_\_ IMP. DIA \_\_\_\_\_

800



# VERTIFLO PUMP COMPANY Performance Curves

Curve ES-1640

Series 800  
 Size 5 X 4 X 8  
 RPM 1750  
 Max Sphere 15/16

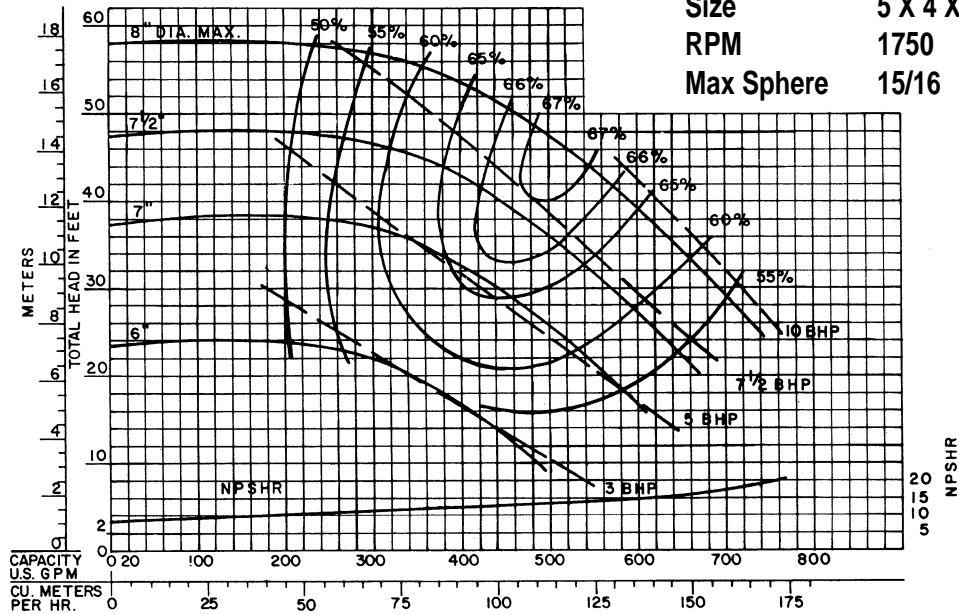

Curve DS-1640

Series 800  
 Size 5 X 4 X 8  
 RPM 1150  
 Max Sphere 15/16

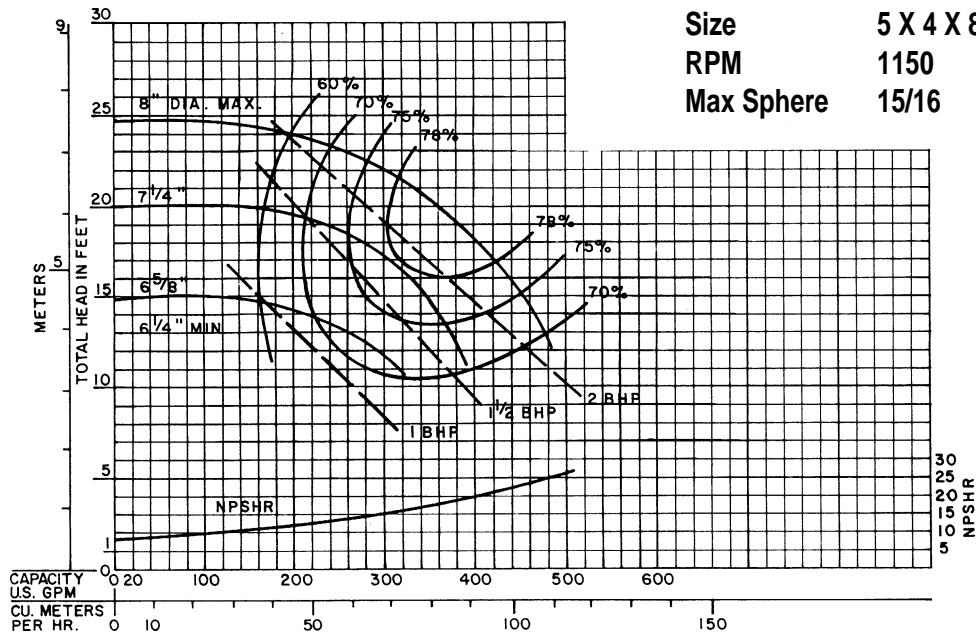

Performance at Casing Discharge Flange

Curves Show Performance with Liquid Having Specific Gravity 1.0 Viscosity • 30 SSU

CUSTOMER \_\_\_\_\_ CUSTOMER NO. \_\_\_\_\_

PROJECT \_\_\_\_\_

ENGINEER \_\_\_\_\_

CONTRACTOR \_\_\_\_\_

CONDITIONS: \_\_\_\_\_ GPM \_\_\_\_\_ TDH \_\_\_\_\_ HP \_\_\_\_\_ EFF% \_\_\_\_\_ IMP. DIA \_\_\_\_\_

# VERTIFLO PUMP COMPANY Performance Curves

**Curve SM-1915**

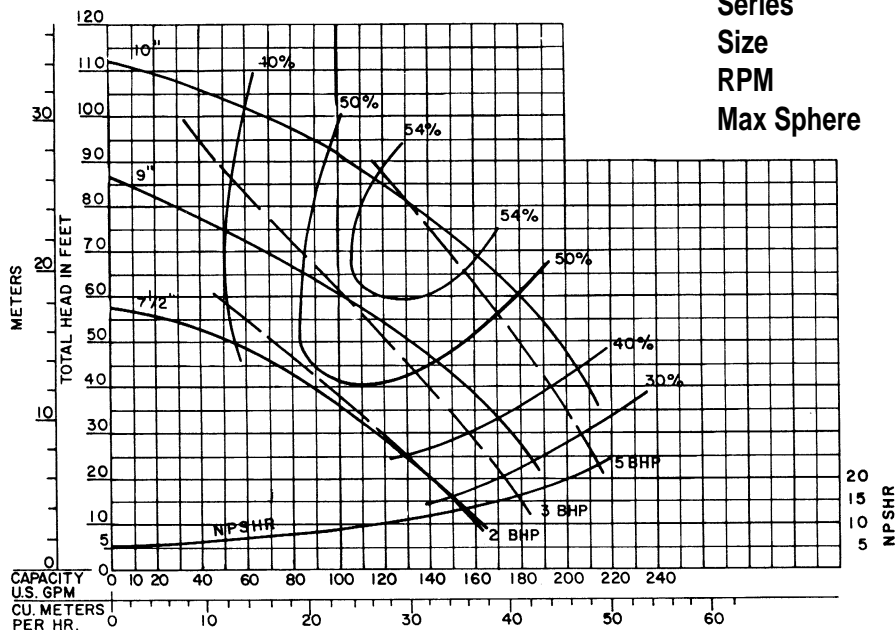

Series 800  
 Size 2 X 1 1/2 X 10  
 RPM 1750  
 Max Sphere 7/16

**Curve TM-1915**

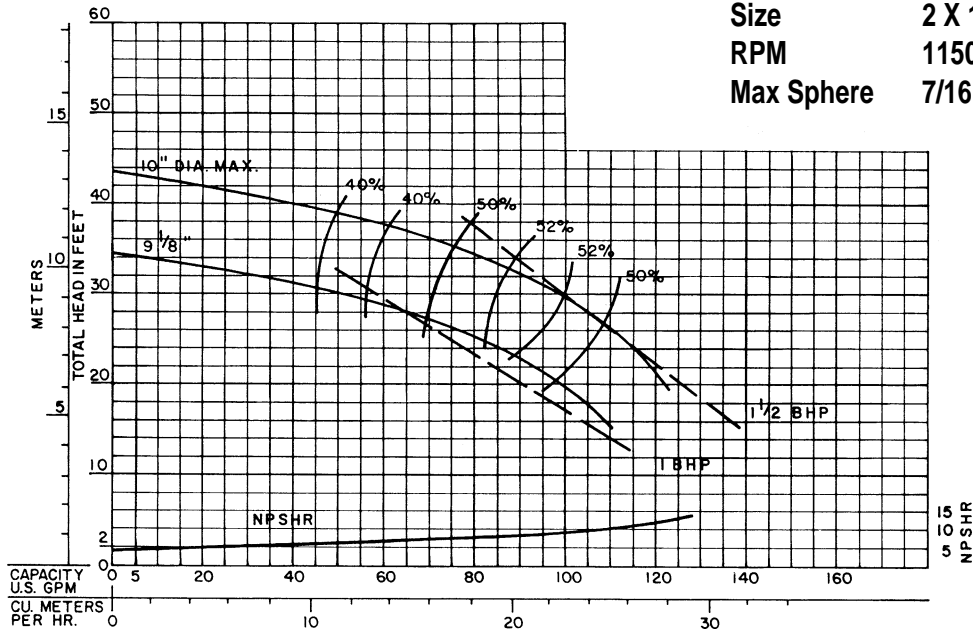

Series 800  
 Size 2 X 1 1/2 X 10  
 RPM 1150  
 Max Sphere 7/16

800

Performance at Casing Discharge Flange

Curves Show Performance with Liquid Having Specific Gravity 1.0 Viscosity • 30 SSU

CUSTOMER \_\_\_\_\_ CUSTOMER NO. \_\_\_\_\_

PROJECT \_\_\_\_\_

ENGINEER \_\_\_\_\_

CONTRACTOR \_\_\_\_\_

CONDITIONS: \_\_\_\_\_ GPM \_\_\_\_\_ TDH \_\_\_\_\_ HP \_\_\_\_\_ EFF% \_\_\_\_\_ IMP. DIA \_\_\_\_\_

# VERTIFLO PUMP COMPANY Performance Curves

Curve JM-1720

Series 800  
 Size 3 X 2 X 10  
 RPM 1750  
 Max Sphere 11/16

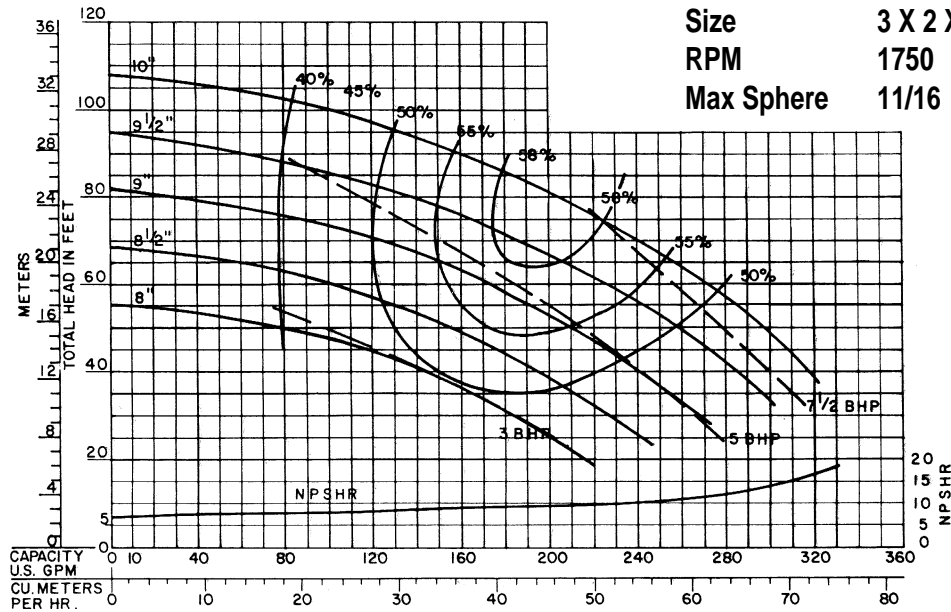

Curve KM-1720

Series 800  
 Size 3 X 2 X 10  
 RPM 1150  
 Max Sphere 11/16

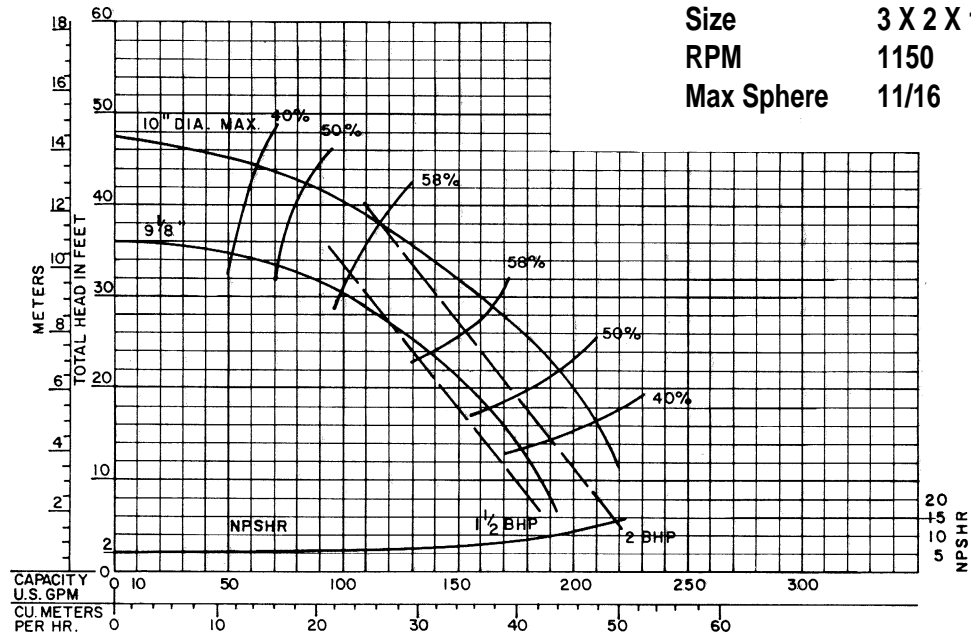

Performance at Casing Discharge Flange

Curves Show Performance with Liquid Having Specific Gravity 1.0 Viscosity • 30 SSU

CUSTOMER \_\_\_\_\_ CUSTOMER NO. \_\_\_\_\_

PROJECT \_\_\_\_\_

ENGINEER \_\_\_\_\_

CONTRACTOR \_\_\_\_\_

CONDITIONS: \_\_\_\_\_ GPM \_\_\_\_\_ TDH \_\_\_\_\_ HP \_\_\_\_\_ EFF% \_\_\_\_\_ IMP. DIA \_\_\_\_\_

# VERTIFLO PUMP COMPANY Performance Curves

Curve RM-1730

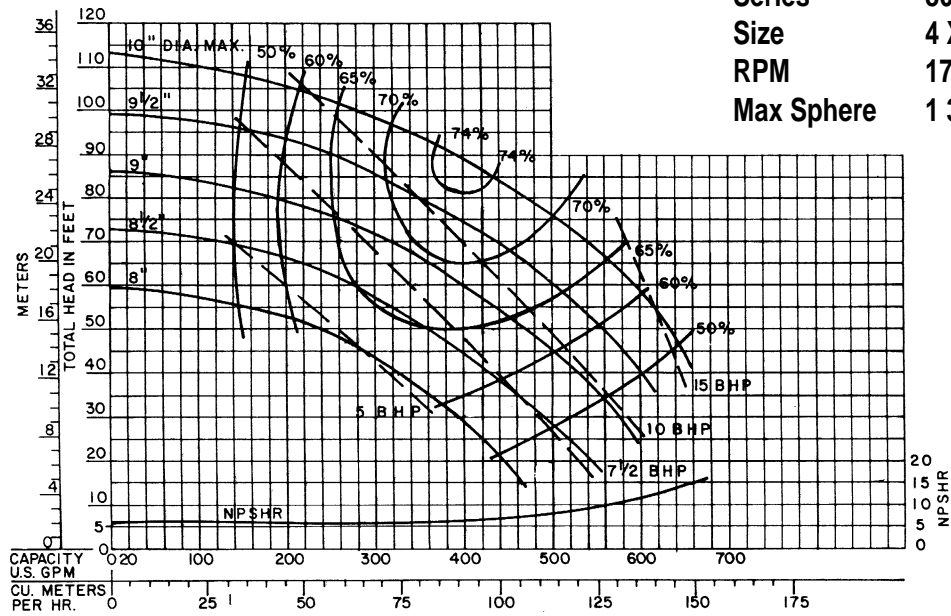

Series 800  
 Size 4 X 3 X 10  
 RPM 1750  
 Max Sphere 1 3/16

Curve SM-1730

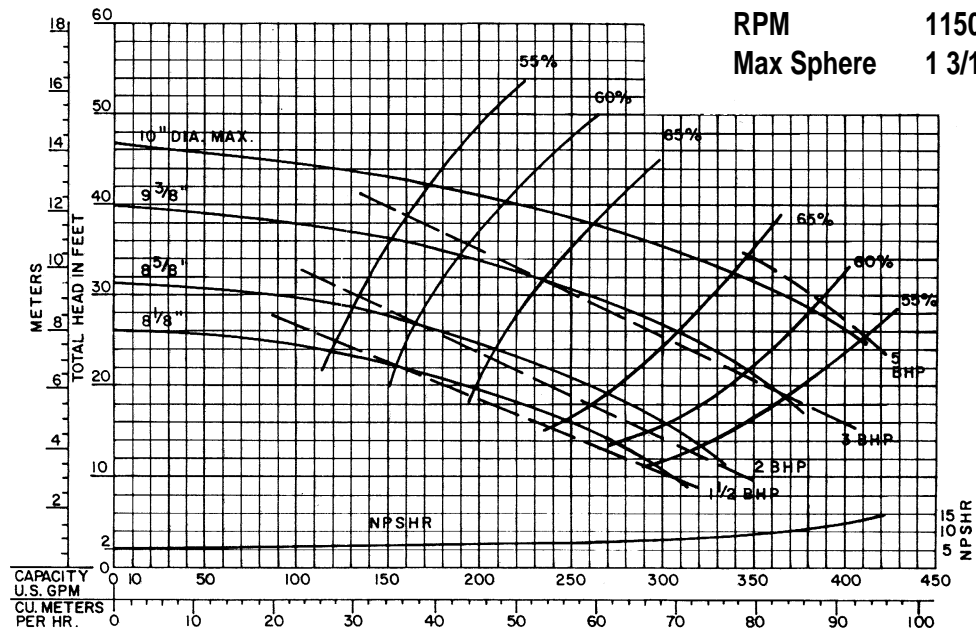

Series 800  
 Size 4 X 3 X 10  
 RPM 1150  
 Max Sphere 1 3/16

Performance at Casing Discharge Flange  
 Curves Show Performance with Liquid Having Specific Gravity 1.0 Viscosity • 30 SSU

CUSTOMER \_\_\_\_\_ CUSTOMER NO. \_\_\_\_\_  
 PROJECT \_\_\_\_\_  
 ENGINEER \_\_\_\_\_  
 CONTRACTOR \_\_\_\_\_  
 CONDITIONS: \_\_\_\_\_ GPM \_\_\_\_\_ TDH \_\_\_\_\_ HP \_\_\_\_\_ EFF% \_\_\_\_\_ IMP. DIA \_\_\_\_\_

# VERTIFLO PUMP COMPANY Performance Curves

Curve TM-1740

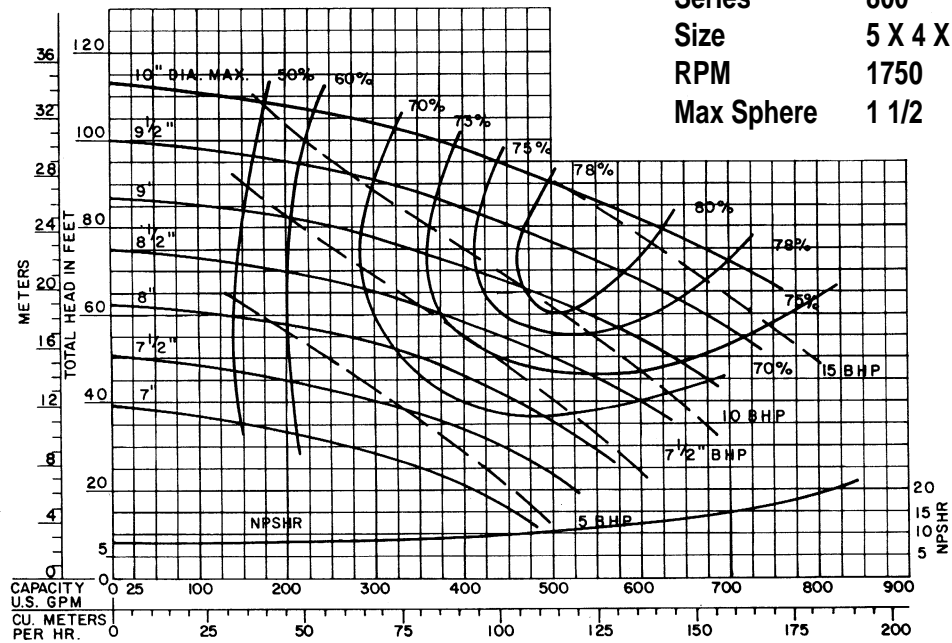

Curve UM-1740

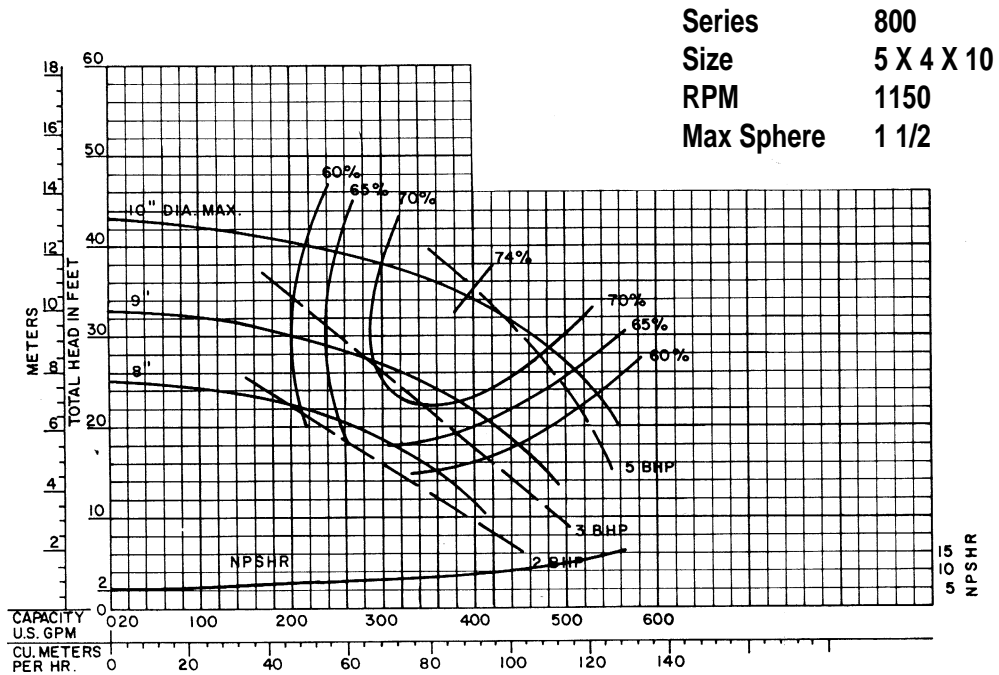

Performance at Casing Discharge Flange

Curves Show Performance with Liquid Having Specific Gravity 1.0 Viscosity • 30 SSU

CUSTOMER \_\_\_\_\_ CUSTOMER NO. \_\_\_\_\_

PROJECT \_\_\_\_\_

ENGINEER \_\_\_\_\_

CONTRACTOR \_\_\_\_\_

CONDITIONS: \_\_\_\_\_ GPM \_\_\_\_\_ TDH \_\_\_\_\_ HP \_\_\_\_\_ EFF% \_\_\_\_\_ IMP. DIA \_\_\_\_\_

# VERTIFLO PUMP COMPANY Performance Curves

Curve UM-1750

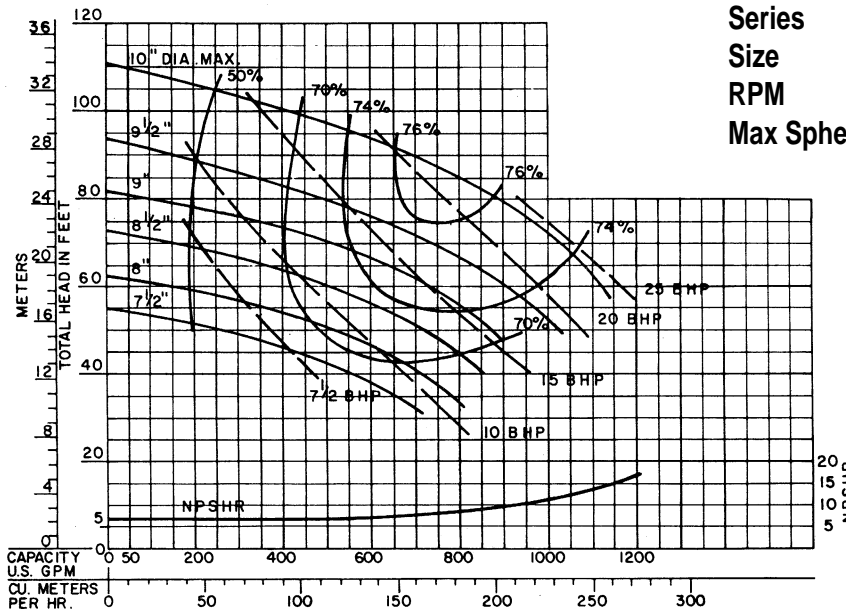

Series 800  
 Size 6 X 5 X 10  
 RPM 1750  
 Max Sphere 1

Curve VM-1750

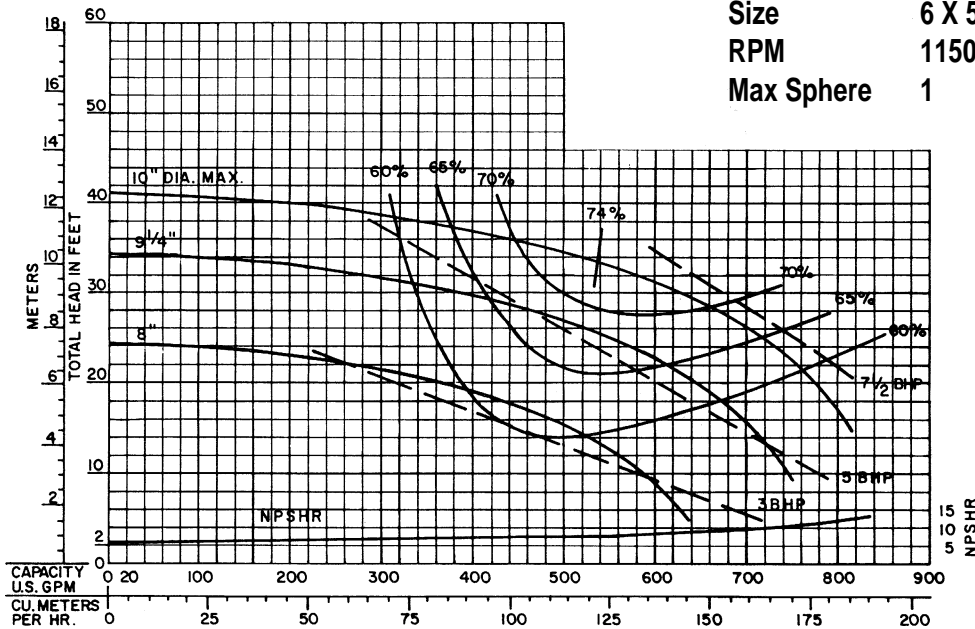

Series 800  
 Size 6 X 5 X 10  
 RPM 1150  
 Max Sphere 1

800

Performance at Casing Discharge Flange  
 Curves Show Performance with Liquid Having Specific Gravity 1.0 Viscosity • 30 SSU

CUSTOMER \_\_\_\_\_ CUSTOMER NO. \_\_\_\_\_  
 PROJECT \_\_\_\_\_  
 ENGINEER \_\_\_\_\_  
 CONTRACTOR \_\_\_\_\_  
 CONDITIONS: \_\_\_\_\_ GPM \_\_\_\_\_ TDH \_\_\_\_\_ HP \_\_\_\_\_ EFF% \_\_\_\_\_ IMP. DIA \_\_\_\_\_

# VERTIFLO PUMP COMPANY Performance Curves

Curve SM-1750

Series 800  
 Size 6 X 5 X 10A  
 RPM 1750  
 Max Sphere 1 1/2

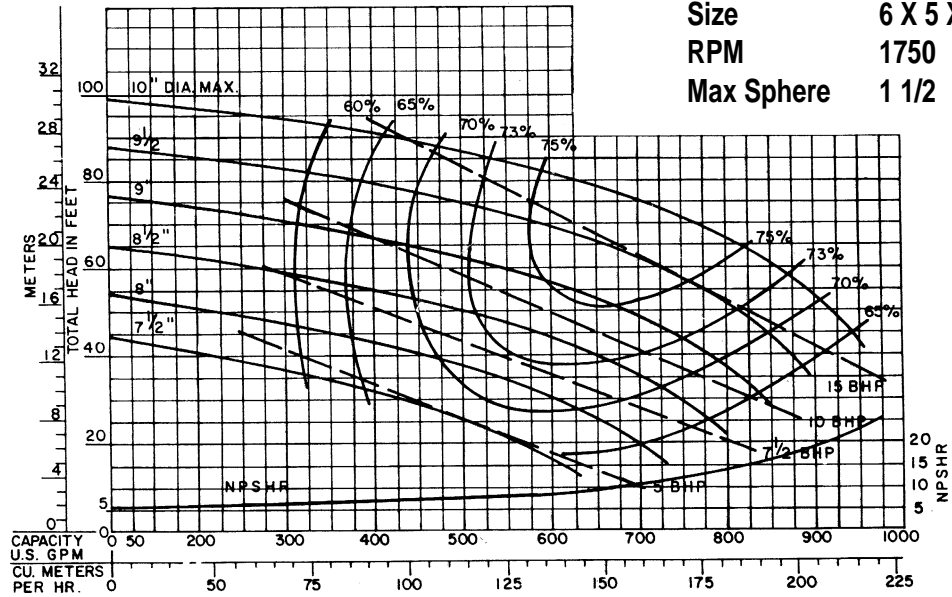

Curve SM-1850

Series 800  
 Size 6 X 5 X 10A  
 RPM 1150  
 Max Sphere 1 1/2

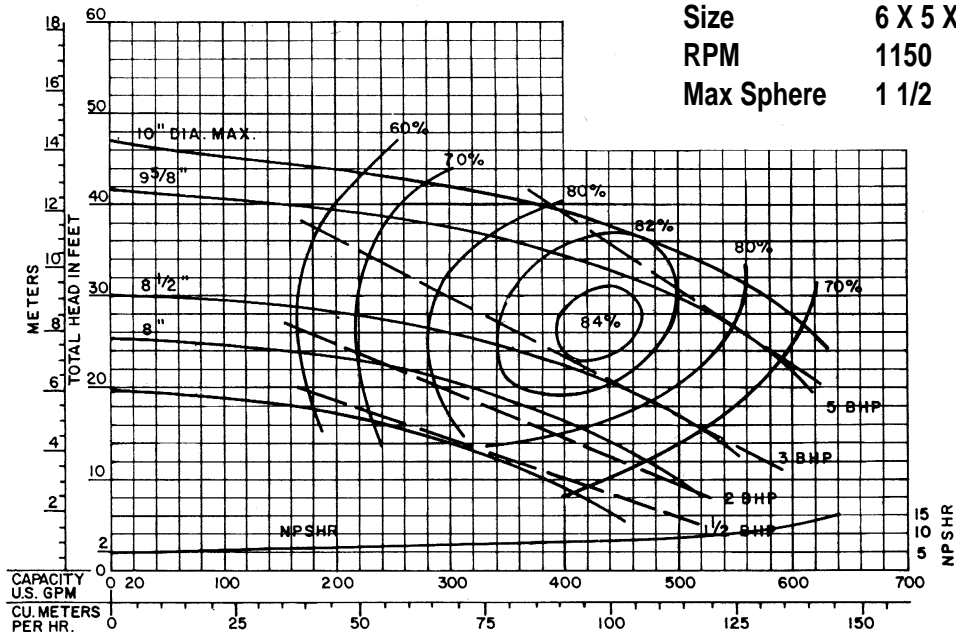

Performance at Casing Discharge Flange

Curves Show Performance with Liquid Having Specific Gravity 1.0 Viscosity • 30 SSU

CUSTOMER \_\_\_\_\_ CUSTOMER NO. \_\_\_\_\_

PROJECT \_\_\_\_\_

ENGINEER \_\_\_\_\_

CONTRACTOR \_\_\_\_\_

CONDITIONS: \_\_\_\_\_ GPM \_\_\_\_\_ TDH \_\_\_\_\_ HP \_\_\_\_\_ EFF% \_\_\_\_\_ IMP. DIA \_\_\_\_\_

# VERTIFLO PUMP COMPANY Performance Curves

Curve TM-1760

Series 800  
 Size 6 X 6 X 10  
 RPM 1750  
 Max Sphere 1 1/8

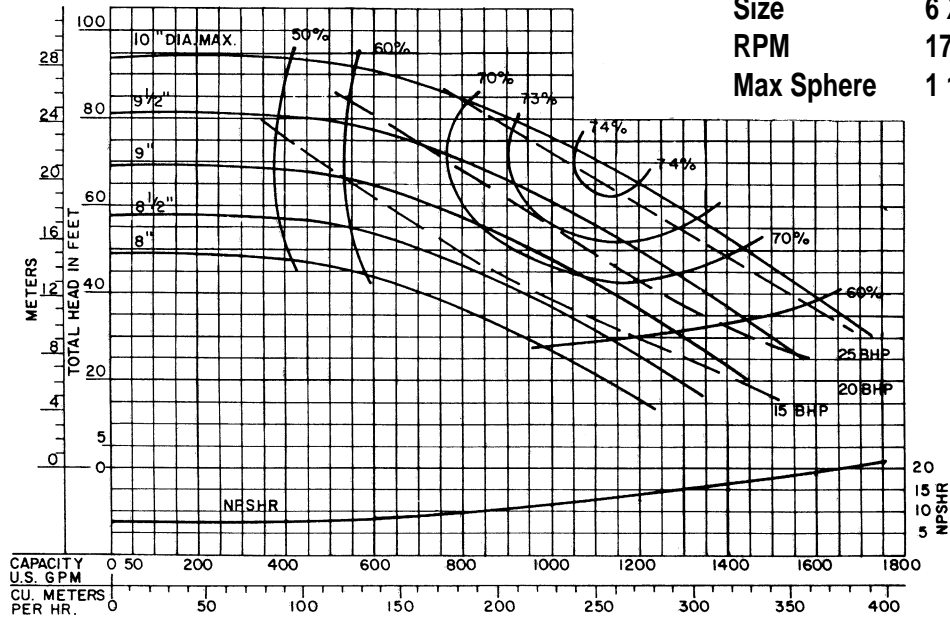

Curve UM-1760

Series 800  
 Size 6 X 6 X 10  
 RPM 1150  
 Max Sphere 1 1/8

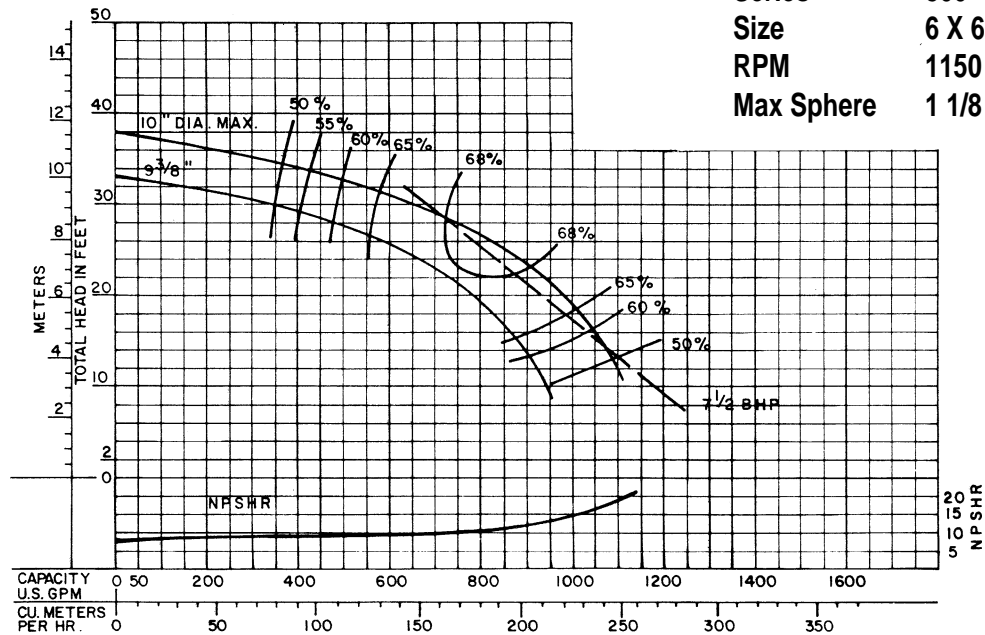

Performance at Casing Discharge Flange

Curves Show Performance with Liquid Having Specific Gravity 1.0 Viscosity • 30 SSU

CUSTOMER \_\_\_\_\_ CUSTOMER NO. \_\_\_\_\_

PROJECT \_\_\_\_\_

ENGINEER \_\_\_\_\_

CONTRACTOR \_\_\_\_\_

CONDITIONS: \_\_\_\_\_ GPM \_\_\_\_\_ TDH \_\_\_\_\_ HP \_\_\_\_\_ EFF% \_\_\_\_\_ IMP. DIA \_\_\_\_\_

800



# VERTIFLO PUMP COMPANY Performance Curves

Curve LM-1760

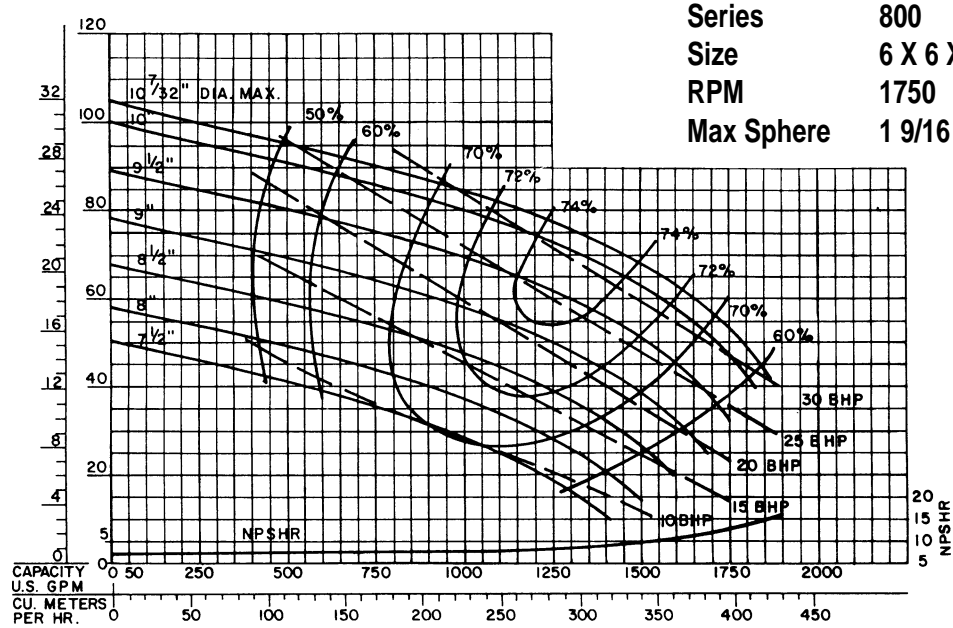

Curve LM-1860

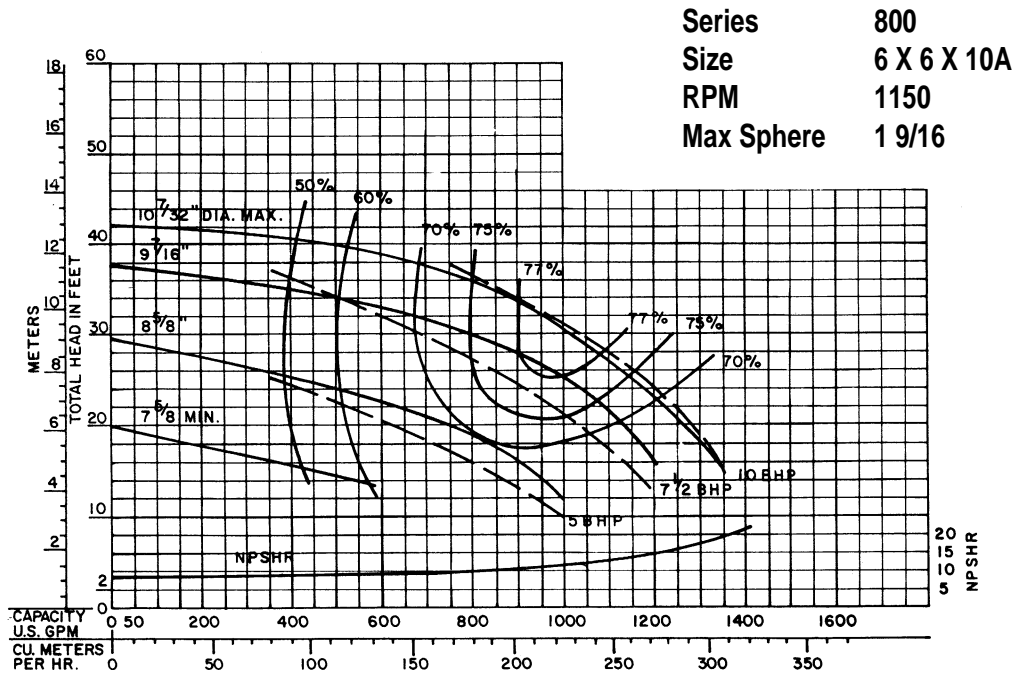

Performance at Casing Discharge Flange

Curves Show Performance with Liquid Having Specific Gravity 1.0 Viscosity • 30 SSU

CUSTOMER \_\_\_\_\_ CUSTOMER NO. \_\_\_\_\_

PROJECT \_\_\_\_\_

ENGINEER \_\_\_\_\_

CONTRACTOR \_\_\_\_\_

CONDITIONS: \_\_\_\_\_ GPM \_\_\_\_\_ TDH \_\_\_\_\_ HP \_\_\_\_\_ EFF% \_\_\_\_\_ IMP. DIA \_\_\_\_\_

# VERTIFLO PUMP COMPANY Performance Curves

Curve KL-1915

Series 800  
 Size 2 X 1 1/2 X 12  
 RPM 1750  
 Max Sphere 7/16

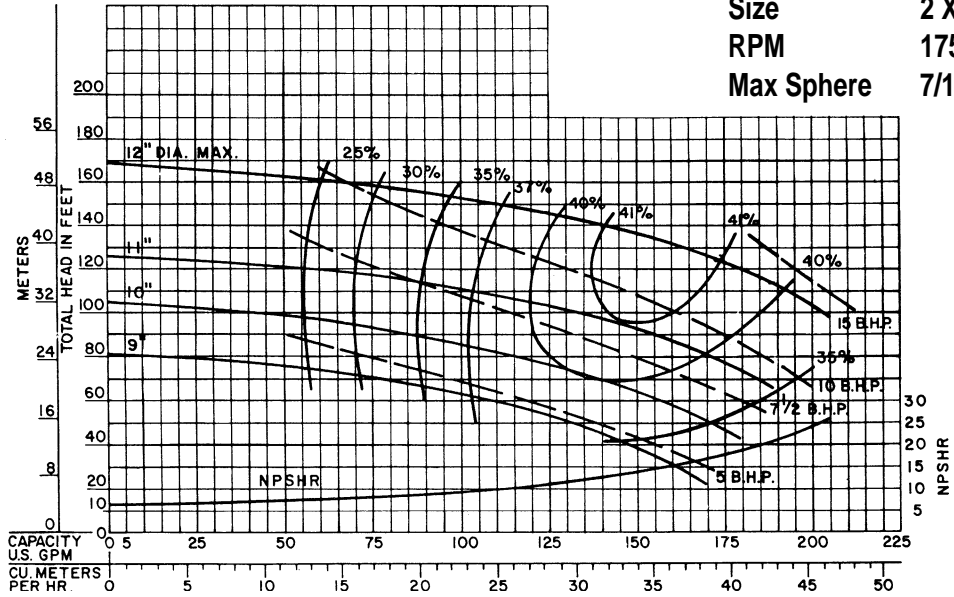

Curve LL-1915

Series 800  
 Size 2 X 1 1/2 X 12  
 RPM 1150  
 Max Sphere 7/16

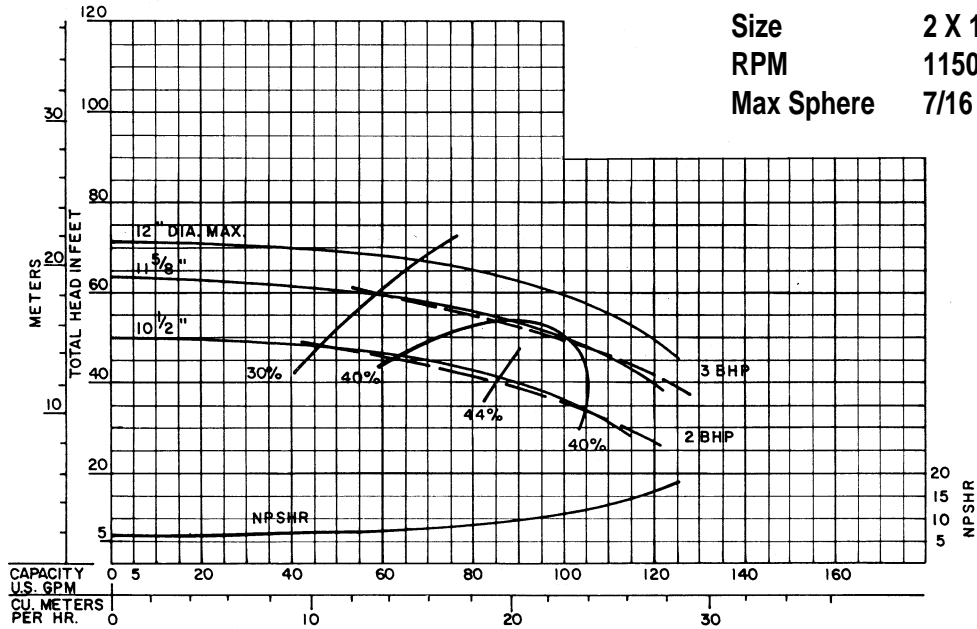

Performance at Casing Discharge Flange  
 Curves Show Performance with Liquid Having Specific Gravity 1.0 Viscosity • 30 SSU

CUSTOMER \_\_\_\_\_ CUSTOMER NO. \_\_\_\_\_  
 PROJECT \_\_\_\_\_  
 ENGINEER \_\_\_\_\_  
 CONTRACTOR \_\_\_\_\_  
 CONDITIONS: \_\_\_\_\_ GPM \_\_\_\_\_ TDH \_\_\_\_\_ HP \_\_\_\_\_ EFF% \_\_\_\_\_ IMP. DIA \_\_\_\_\_

800

# VERTIFLO PUMP COMPANY Performance Curves

**Curve KL-1916**

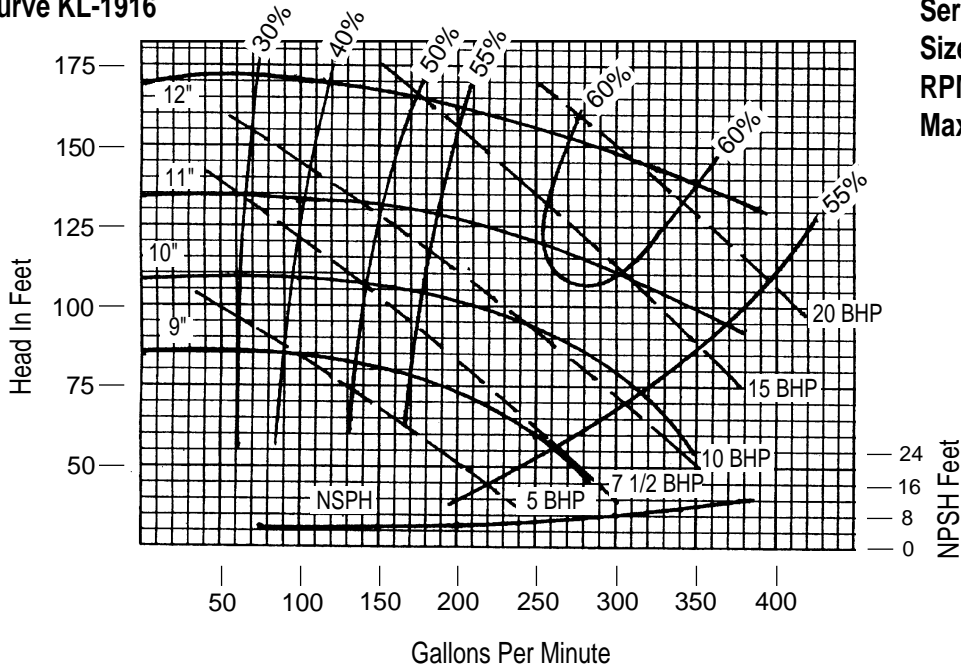

Series 800  
 Size 3 X 2 X 12  
 RPM 1750  
 Max Sphere 3/4

**Curve LL-1916**

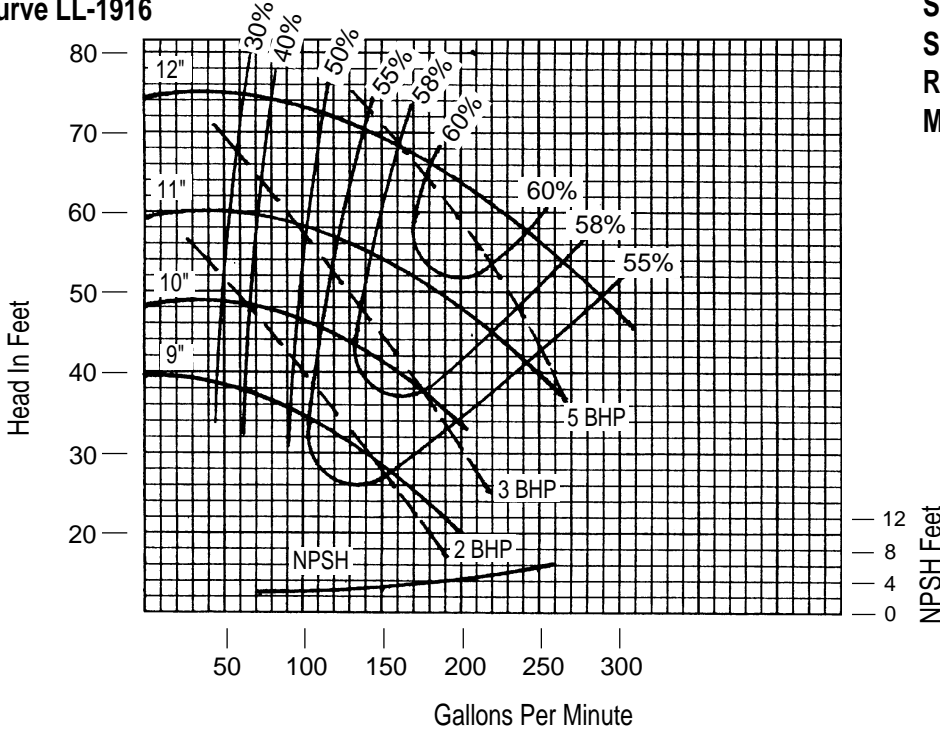

Series 800  
 Size 3 X 2 X 12  
 RPM 1150  
 Max Sphere 3/4

Performance at Casing Discharge Flange

Curves Show Performance with Liquid Having Specific Gravity 1.0 Viscosity • 30 SSU

CUSTOMER \_\_\_\_\_ CUSTOMER NO. \_\_\_\_\_

PROJECT \_\_\_\_\_

ENGINEER \_\_\_\_\_

CONTRACTOR \_\_\_\_\_

CONDITIONS: \_\_\_\_\_ GPM \_\_\_\_\_ TDH \_\_\_\_\_ HP \_\_\_\_\_ EFF% \_\_\_\_\_ IMP. DIA \_\_\_\_\_

# VERTIFLO PUMP COMPANY Performance Curves

**Curve KL-1917**

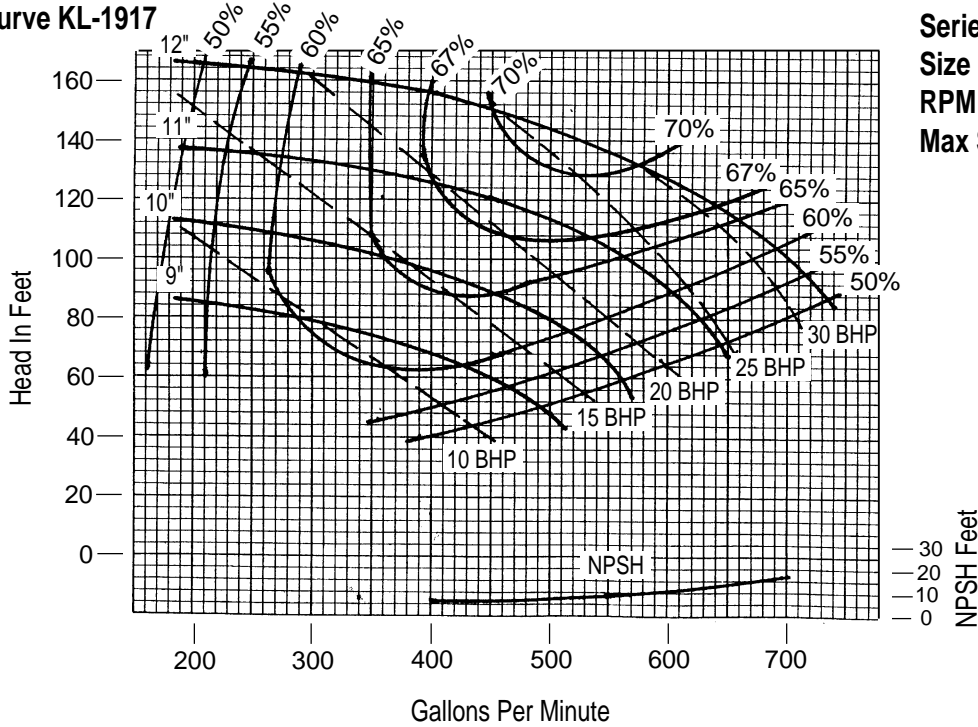

**Curve LL-1917**

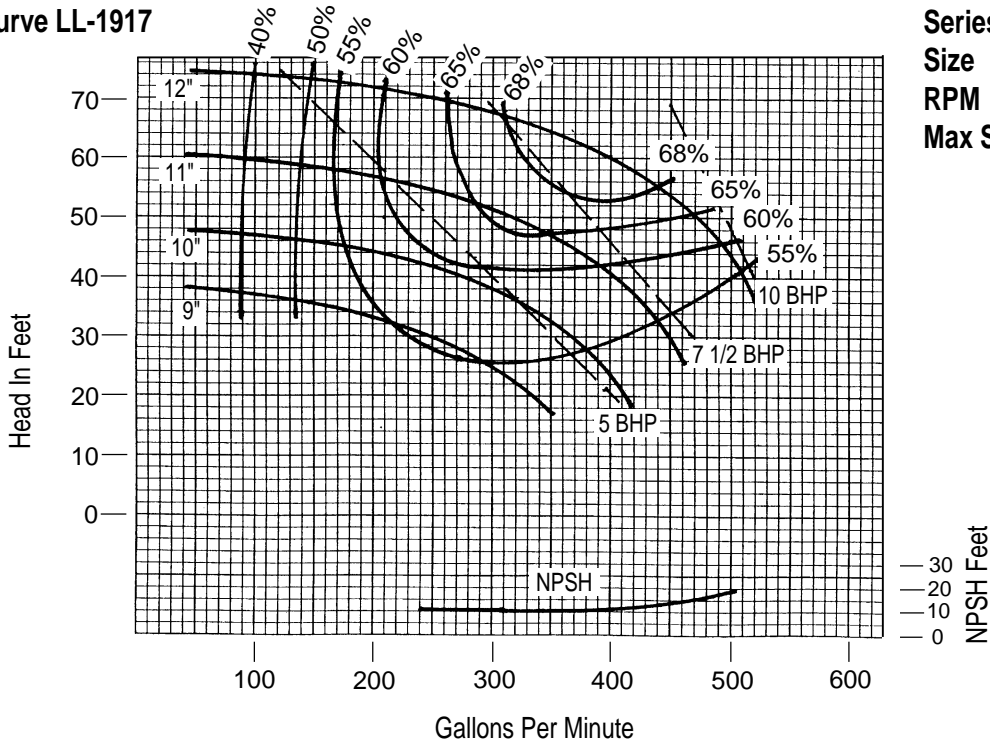

Performance at Casing Discharge Flange

Curves Show Performance with Liquid Having Specific Gravity 1.0 Viscosity • 30 SSU

CUSTOMER \_\_\_\_\_ CUSTOMER NO. \_\_\_\_\_

PROJECT \_\_\_\_\_

ENGINEER \_\_\_\_\_

CONTRACTOR \_\_\_\_\_

CONDITIONS: \_\_\_\_\_ GPM \_\_\_\_\_ TDH \_\_\_\_\_ HP \_\_\_\_\_ EFF% \_\_\_\_\_ IMP. DIA \_\_\_\_\_

# VERTIFLO PUMP COMPANY Performance Curves

Curve 64124

Series 800  
 Size 6 X 4 X 12  
 RPM 1750  
 Max Sphere 1 1/2

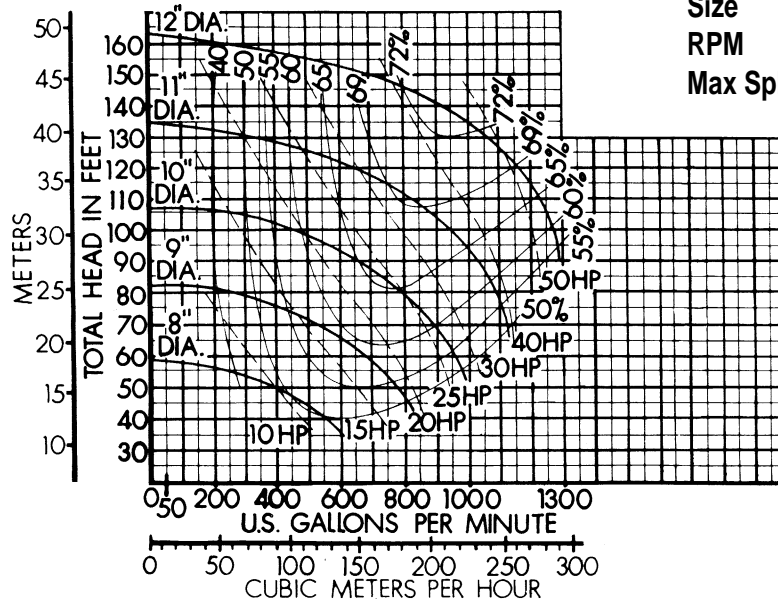

Curve 64126

Series 800  
 Size 6 X 4 X 12  
 RPM 1150  
 Max Sphere 1 1/2

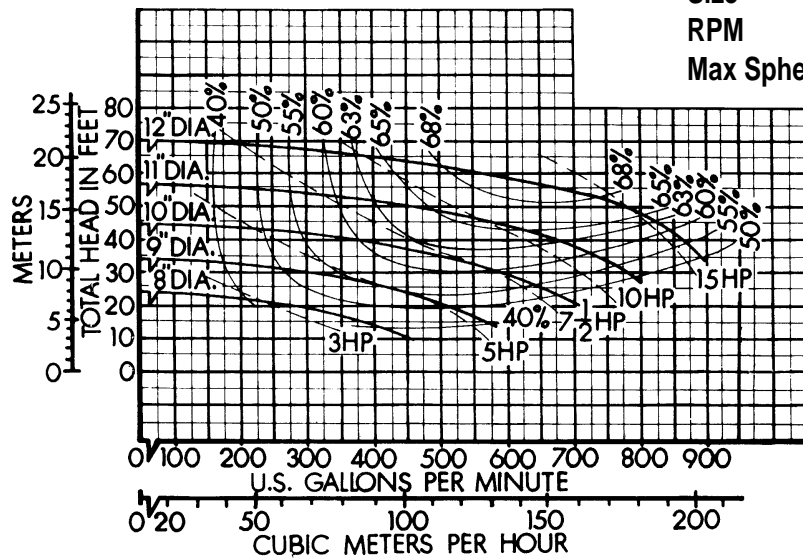

Performance at Casing Discharge Flange

Curves Show Performance with Liquid Having Specific Gravity 1.0 Viscosity • 30 SSU

CUSTOMER \_\_\_\_\_ CUSTOMER NO. \_\_\_\_\_

PROJECT \_\_\_\_\_

ENGINEER \_\_\_\_\_

CONTRACTOR \_\_\_\_\_

CONDITIONS: \_\_\_\_\_ GPM \_\_\_\_\_ TDH \_\_\_\_\_ HP \_\_\_\_\_ EFF% \_\_\_\_\_ IMP. DIA \_\_\_\_\_

# VERTIFLO PUMP COMPANY Performance Curves

Curve 6412A4

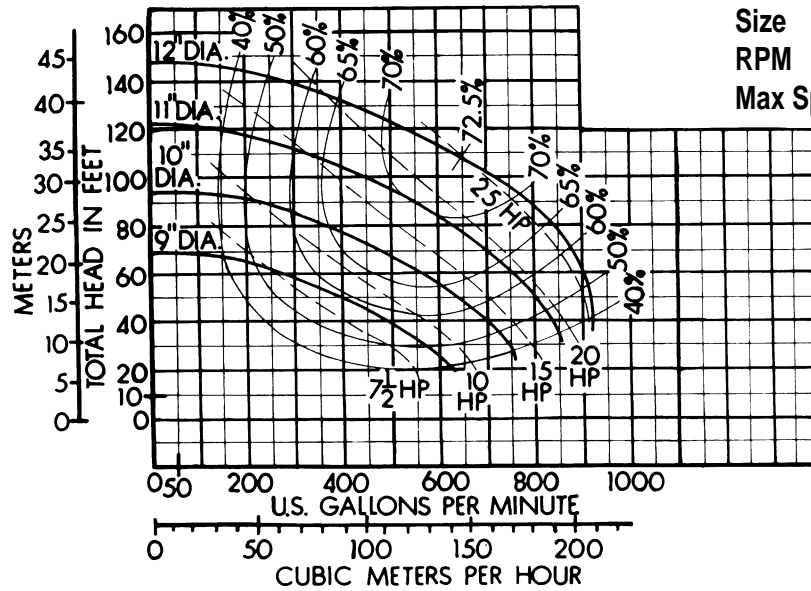

Series 800  
 Size 6 X 4 X 12A  
 RPM 1750  
 Max Sphere 1 1/8

Curve 6412A6

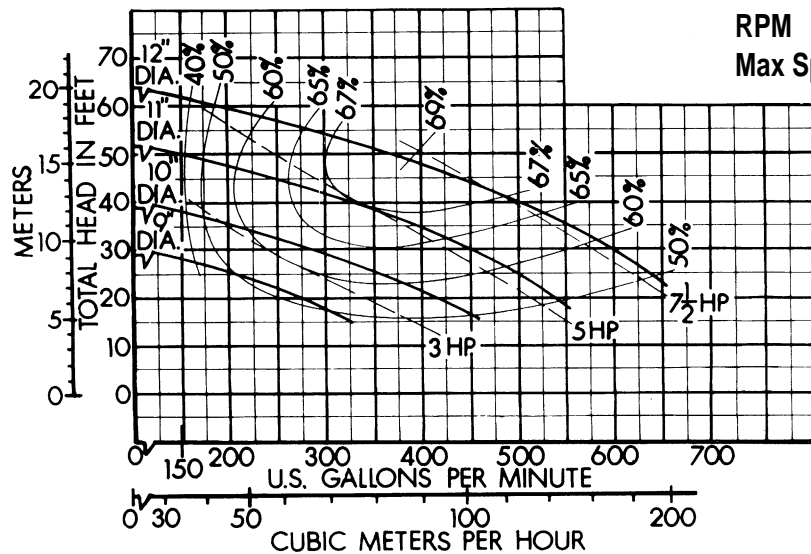

Series 800  
 Size 6 X 4 X 12A  
 RPM 1150  
 Max Sphere 1 1/8

Performance at Casing Discharge Flange

Curves Show Performance with Liquid Having Specific Gravity 1.0 Viscosity • 30 SSU

CUSTOMER \_\_\_\_\_ CUSTOMER NO. \_\_\_\_\_

PROJECT \_\_\_\_\_

ENGINEER \_\_\_\_\_

CONTRACTOR \_\_\_\_\_

CONDITIONS: \_\_\_\_\_ GPM \_\_\_\_\_ TDH \_\_\_\_\_ HP \_\_\_\_\_ EFF% \_\_\_\_\_ IMP. DIA \_\_\_\_\_

# VERTIFLO PUMP COMPANY Performance Curves

Curve 66124

Series 800  
 Size 6 X 6 X 12  
 RPM 1750  
 Max Sphere 1 1/2

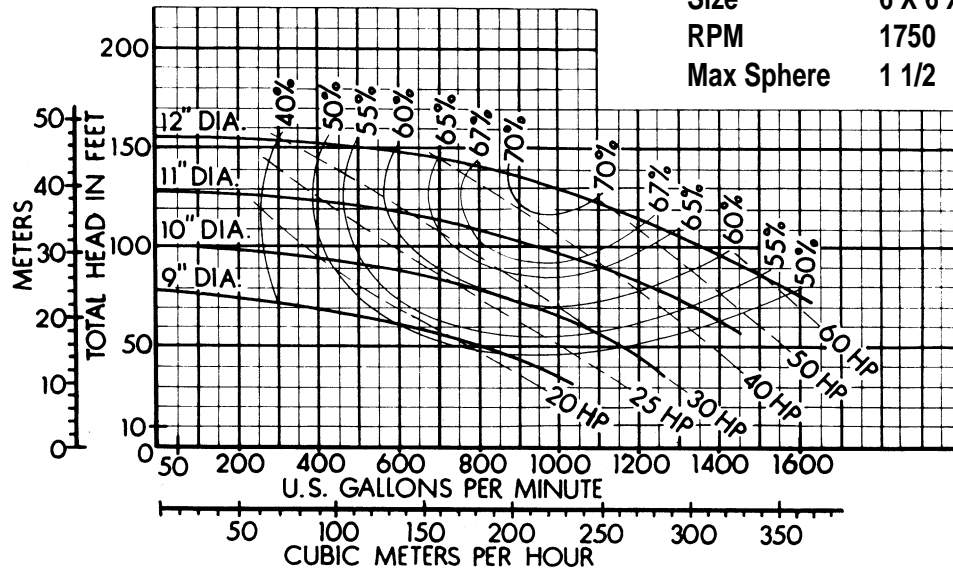

Curve 66126

Series 800  
 Size 6 X 6 X 12  
 RPM 1150  
 Max Sphere 1 1/2

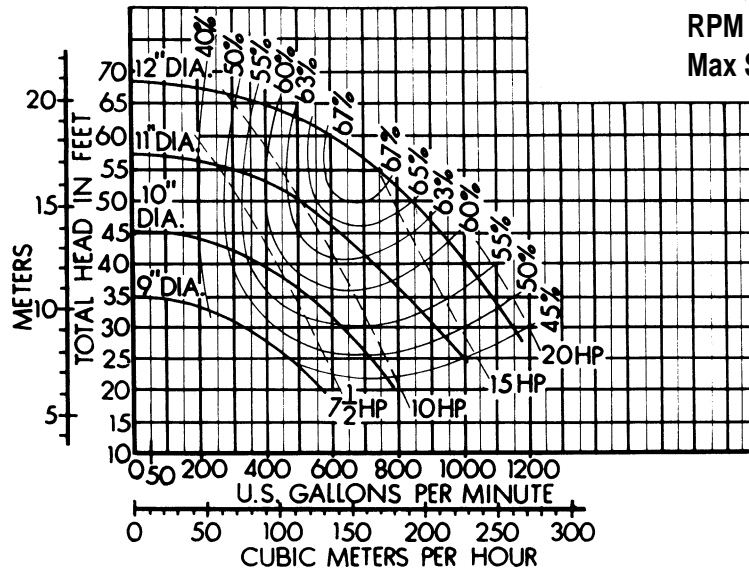

Performance at Casing Discharge Flange

Curves Show Performance with Liquid Having Specific Gravity 1.0 Viscosity • 30 SSU

CUSTOMER \_\_\_\_\_ CUSTOMER NO. \_\_\_\_\_

PROJECT \_\_\_\_\_

ENGINEER \_\_\_\_\_

CONTRACTOR \_\_\_\_\_

CONDITIONS: \_\_\_\_\_ GPM \_\_\_\_\_ TDH \_\_\_\_\_ HP \_\_\_\_\_ EFF% \_\_\_\_\_ IMP. DIA \_\_\_\_\_

# VERTIFLO PUMP COMPANY Performance Curves

Curve 88124

Series 800  
 Size 8 X 8 X 12  
 RPM 1750  
 Max Sphere 1 1/2

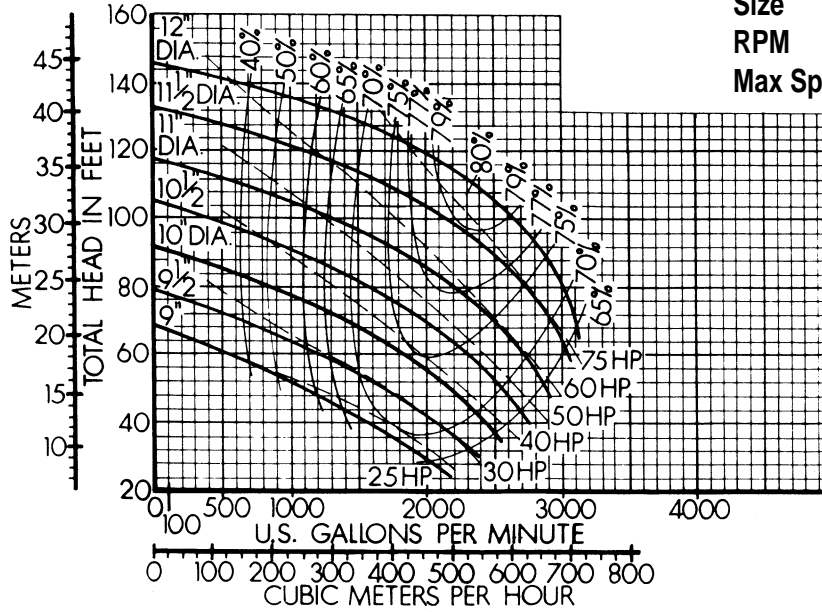

Curve 88126

Series 800  
 Size 8 X 8 X 12  
 RPM 1150  
 Max Sphere 1 1/2

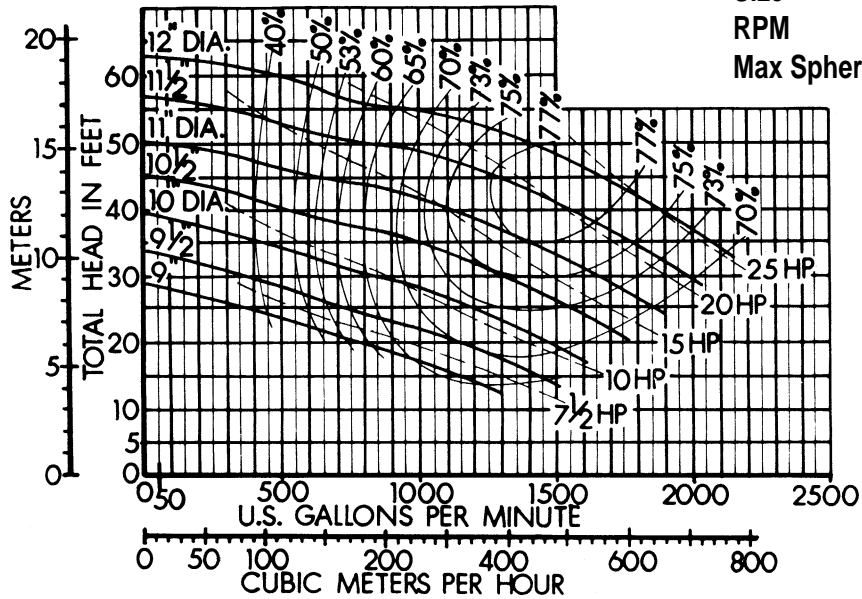

Performance at Casing Discharge Flange

Curves Show Performance with Liquid Having Specific Gravity 1.0 Viscosity • 30 SSU

CUSTOMER \_\_\_\_\_ CUSTOMER NO. \_\_\_\_\_

PROJECT \_\_\_\_\_

ENGINEER \_\_\_\_\_

CONTRACTOR \_\_\_\_\_

CONDITIONS: \_\_\_\_\_ GPM \_\_\_\_\_ TDH \_\_\_\_\_ HP \_\_\_\_\_ EFF% \_\_\_\_\_ IMP. DIA \_\_\_\_\_



# VERTIFLO PUMP COMPANY Dimensions

## 800-S Simplex Sump Pump

### PUMP DATA

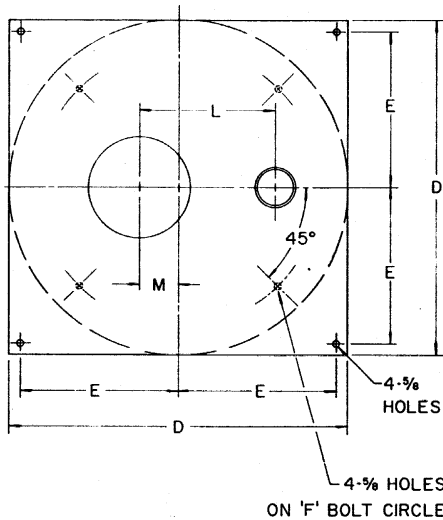
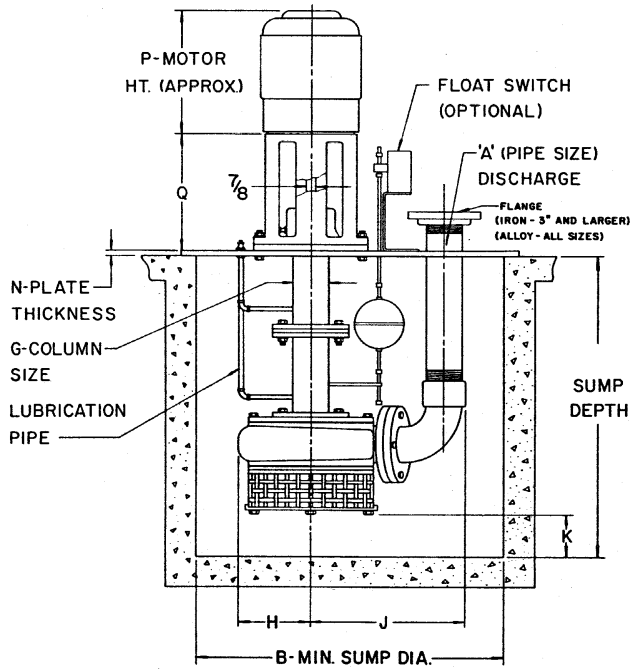

SIZE	MODEL	A	B	C	D	E	F	G	H	J	K <sup>(2)</sup>	L	M	N
3x2 1/2x7	820-S	2 1/2	24	2 TO 26' IN 1' INCREMENTS	28	13	26	4	5 1/2	13 1/2	2 7/8	11 1/8	4 1/4	3/8
		3								14 1/4	12	9 5/8	3/8	
1 1/2x1x8	820-S	1	24							10 5/8	4 1/8	9 5/8	4 1/4	3/8
		1 1/2								11 1/8	4 1/8	10	4 1/4	3/8
1 1/2x1 1/4x8	820-S	1 1/2	24							11 1/8	3 1/8	10 3/8	4 1/4	3/8
		2								12	3 1/8	10 3/8	4 1/4	3/8
2x1 1/2x8	820-S	1 1/2	24							11 1/8	3 3/4	10 3/8	4 1/4	3/8
		2								12	3 3/4	10 3/8	4 1/4	3/8
3x2x8	820-S	2 1/2	24							12 5/8	3 3/8	11 1/8	4 1/4	3/8
		3								13 3/8	3 3/8	11 1/8	4 1/4	3/8
4x3x8	820-S	4	24							15 5/8	1 1/2	13 7/8	5 1/4	3/8
		4								16 5/8	1 1/2	13 7/8	5 1/4	3/8
5x4x8	820-S	5	30							17 1/8	1 1/8	14 1/2	6 1/8	3/8
		5								17 3/8	1 1/8	15	6 1/8	3/8
2x1 1/2x10	820-S	1 1/2	34							12 1/2	5	11 1/4	4 1/4	3/8
		2								13	5	11 1/4	4 1/4	3/8
3x2x10	820-S	2 1/2	24							13 3/4	5	12 5/8	4 1/4	3/8
		3								14 3/4	5	12 5/8	4 1/4	3/8
4x3x10	820-S	4	30							17 1/8	2 3/4	15 1/4	6 1/8	3/8
		4								17 3/8	2 3/4	15 1/4	6 1/8	3/8
5x4x10	824-S	5	30	19 1/8	1 1/8	17	6 1/8	3/8						
		5		20 1/8	1 1/8	17	6 1/8	3/8						
6x5x10	824-S	6	36	20 7/8	1 1/8	17 1/2	6 1/4	1/2						
		6		21 7/8	1 1/8	18	6 1/4	1/2						
6x6x10	824-S	6	36	22 1/2	7/8	18 1/2	7 1/4	1/2						
		6		22 7/8	7/8	19 1/2	7 1/4	1/2						
6x6x10A	824-S	8	36	25	7/8	19 3/4	7 1/4	1/2						
		8		25 1/2	7/8	19 3/4	7 1/4	1/2						
2x1 1/2x12	824-S	1 1/2	24	12 7/8	2 1/8	12	4 1/4	3/8						
		2		13 7/8	2 1/8	12	4 1/4	3/8						
3x2x12	824-S	3	36	15 3/4	2	15	6	1/2						
		3		17 1/4	2	15	6	1/2						
4x3x12	824-S	3	36	18	1 3/8	15 3/4	6	1/2						
		4		19	1 3/8	16 1/4	6	1/2						

FRAME	P	Q
56 C	10 7/16	12
143 TC	10	12
145 TC	10 7/16	12
182 - 184 TC	13 1/2	12
213 TC	15 1/2	12
215 TC	17	12
254 TC	20 1/8	12
256 TC	21 7/8	12
284 TC	22 3/8	13
286 TC	23 7/8	13
324 TC	24 3/4	13 1/2
326 TC	26 1/8	13 1/2
364 TC	26 1/2	16 5/8
365 TC	27 1/2	16 5/8

### MOTOR DATA

"K" dimension shown is for a pump built for a 2' through 6' pit depth. For each additional column section, subtract 3/8" from "K."

Not for construction unless certified, some dimensions may vary ± 1/2". Pump Construction: \_\_\_\_\_

CUSTOMER \_\_\_\_\_ CUSTOMER NO. \_\_\_\_\_  
 PROJECT \_\_\_\_\_ SERIAL NO. \_\_\_\_\_  
 ENGINEER \_\_\_\_\_ LOCATION \_\_\_\_\_  
 CONTRACTOR \_\_\_\_\_  
 PUMP Model Size Curve No. GPM Head SP. GR. @Temp. Pump Length Plate  
 DATA \_\_\_\_\_  
 MOTOR Mfgr. HP RPM Volt-Phase-Cycle Frame ENC. Furnished by Mounted by  
 DATA \_\_\_\_\_  
 Shop Order \_\_\_\_\_ Certified by \_\_\_\_\_ Date \_\_\_\_\_

# VERTIFLO PUMP COMPANY Dimensions

## 800-S Duplex Sump Pump

### PUMP DATA

SIZE	MODEL	A	B	C	D	F	G	H	J	K <sup>(2)</sup>	L	M	N
3x2½x7	820-S	2½/3	48	2' TO 20' IN 1' INCREMENTS	54	51	4	5½	13½/14½	27/12	11½/12	8¾	10½
1½x1x8	820-S	1½	48		54	51	4	5¾	10½/11½	4½/9¾	9½/9¾	8¾	10½
1½x1¼x8	820-S	1½/2	48		54	51	4	5¾	11½/12	3½/10¾	10/10¾	8¾	10½
2x1½x8	820-S	1½/2	48		54	51	4	5¾	11½/12	3¾/10¾	10/10¾	8¾	10½
3x2x8	820-S	2/2½	48		54	51	4	5¾	12½/13¾	3¾/11½	11½/11½	8¾	10½
4x3x8	820-S	3/4	48		54	51	4	6	15½/16¾	1½/13¾	13¾/13¾	8¾	10½
5x4x8	820-S	4/5	54		60	57	4	7	17½/18¾	1½/15	14½/15	8½	11
2x1½x10	820-S	1½/2	48		54	51	4	6½	12½/13	5/11½	11¼/11½	8¾	10½
3x2x10	820-S	2/2½	48		54	51	4	6¾	13½/14½	5/12¾	12¾/12¾	8¾	10½
4x3x10	820-S	3/4	54		60	57	4	6¾	17/18	2¾/15¼	14¾/15¼	11½	11
5x4x10	824-S	4/5	54		60	57	4	7¾	19¼/20¾	1½/17	16½/17	13	11
6x5x10	824-S	5/6	60		66	63	4	8	20¾/21¾	1½/18	17½/18	13	12½
6x6x10	824-S	6/8	60		66	63	4	9½	22½/25	7/8	18½/19¾	12½	12½
2x1½x12	824-S	1½/2	48		54	51	4	7¾	12½/13½	2½/12	11½/12	8¾	10½
3x2x12	824-S	2/3	54		60	57	4	8	15¾/17½	2½/15	14¼/15	12	11
4x3x12	824-S	3/4	54		60	57	4	8	18/19	2½/16¾	15¾/16¾	12	11

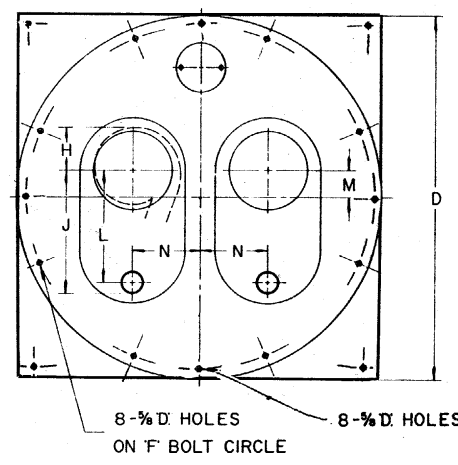
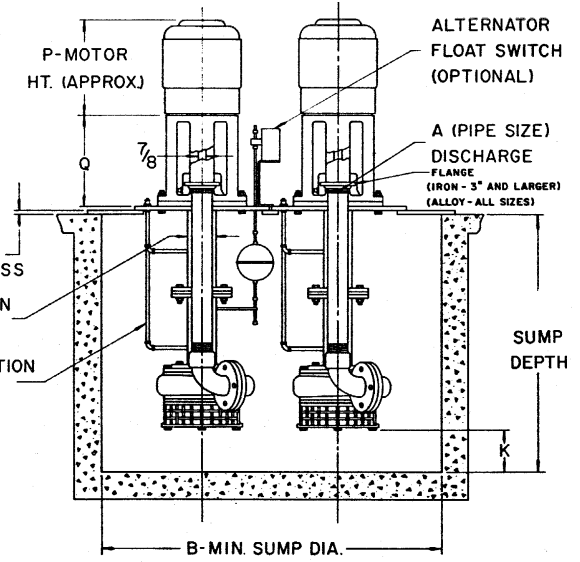

### MOTOR DATA

FRAME	P	Q
56 C	10½/16	12
143 TC	10	12
145 TC	10½/16	12
182 - 184 TC	13½	12
213 TC	15½	12
215 TC	17	12
254 TC	20½	12

FRAME	P	Q
256 TC	21¾	12
284 TC	22¾	13
286 TC	23¾	13
324 TC	24¾	13½
326 TC	26½	13½
364 TC	26½	16¾
365 TC	27½	16¾

"K" dimension shown is for a pump built for a 2' through 6' pit depth. For each additional column section, subtract 3/8" from "K."

Not for construction unless certified, some dimensions may vary ± 1/2". Pump Construction: \_\_\_\_\_

CUSTOMER \_\_\_\_\_ CUSTOMER NO. \_\_\_\_\_  
 PROJECT \_\_\_\_\_ SERIAL NO. \_\_\_\_\_  
 ENGINEER \_\_\_\_\_ LOCATION \_\_\_\_\_  
 CONTRACTOR \_\_\_\_\_  
 PUMP Model \_\_\_\_\_ Size \_\_\_\_\_ Curve No. \_\_\_\_\_ GPM \_\_\_\_\_ Head \_\_\_\_\_ SP. GR. @ Temp. \_\_\_\_\_ Pump Length \_\_\_\_\_ Plate DATA \_\_\_\_\_  
 MOTOR Mfg. \_\_\_\_\_ HP \_\_\_\_\_ RPM \_\_\_\_\_ Volt-Phase-Cycle \_\_\_\_\_ Frame ENC. \_\_\_\_\_ Furnished by \_\_\_\_\_ Mounted by DATA \_\_\_\_\_  
 Shop Order \_\_\_\_\_ Certified by \_\_\_\_\_ Date \_\_\_\_\_

# VERTIFLO PUMP COMPANY Dimensions

## 800-S Basic Sump Pump

### PUMP DATA

SIZE	MODEL	A	B	C	D	E	F	G	H	J	K <sup>(2)</sup>	L	M	N
3x2 1/2 x 7	820-S	2 1/2 3	18	2' TO 20' IN 1' INCREMENTS	26	8	4	4	5 1/2	13 1/2 14 1/2	2 7/8	11 1/8 12	4 3/4	3 3/8
1 1/2 x 1 x 8	820-S	1 1 1/2	18		26	8	4	4	5 3/4	10 5/8 11 1/8	4 1/8	9 5/8 9 7/8	4 3/4	3 3/8
1 1/2 x 1 1/4 x 8	820-S	1 1/2 2	18		26	8	4	4	5 3/4	11 3/8 12	3 1/2	10 10 3/8	4 3/4	3 3/8
2 x 1 1/2 x 8	820-S	1 1/2 2	18		26	8	4	4	5 3/4	11 3/8 12	3 3/4	10 10 3/8	4 3/4	3 3/8
3 x 2 x 8	820-S	2 2 1/2	18		26	8	4	4	5 3/4	12 3/8 13 3/8	3 3/8	11 1/8 11 1/2	4 3/4	3 3/8
4 x 3 x 8	820-S	3 4	18		26	8	4	4	6	15 5/8 16 3/8	1 1/2	13 3/8 13 7/8	5 3/4	3 3/8
5 x 4 x 8	820-S	4 5	21		30	9 1/2	4 1/2	4	7	17 1/8 17 3/8	1 1/8	14 1/2 15	6 1/2	3 3/8
2 x 1 1/2 x 10	820-S	1 1/2 2	18		26	8	4	4	6 1/2	12 1/2 13	5	11 1/4 11 1/2	4 3/4	3 3/8
3 x 2 x 10	820-S	2 2 1/2	18		26	8	4	4	6 3/8	13 3/4 14 1/2	5	12 3/8 12 3/8	4 3/4	3 3/8
4 x 3 x 10	820-S	3 4	21		30	9 1/2	4 1/2	4	7	17 1/8 18	2 3/4	14 7/8 15 1/4	6 1/2	3 3/8
5 x 4 x 10	824-S	4 5	24		34	9 1/2	6 1/2	4	7 3/8	19 1/4 20 3/8	1 1/8	16 1/2 17	7	1 1/2
6 x 5 x 10 6 x 5 x 10A	824-S	5 6	21		34	9 1/2	6 1/2	4	8	20 7/8 21 7/8	1 1/8	17 1/2 18	7	1 1/2
6 x 6 x 10 6 x 6 x 10A	824-S	6 8	24		39	11	7 1/2	4	9 1/2	22 1/2 25	7/8	18 1/2 19 3/8	8	1 1/2
2 x 1 1/2 x 12	824-S	1 1/2 2	20		26	9	3	4	7 3/8	12 7/8 13 1/2	2 1/8	11 3/8 12	4 1/4	3 3/8
3 x 2 x 12	824-S	2 3	21		34	9 1/2	6 1/2	4	8	15 3/4 17 1/4	2	14 1/4 15	6	1 1/2
4 x 3 x 12	824-S	3 4	21		34	9 1/2	6 1/2	4	8	18 19	1 3/8	15 3/4 16 1/4	6	1 1/2

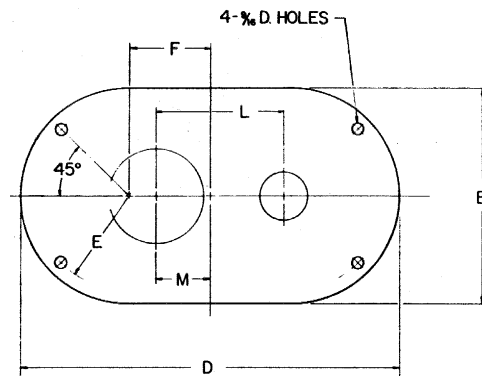
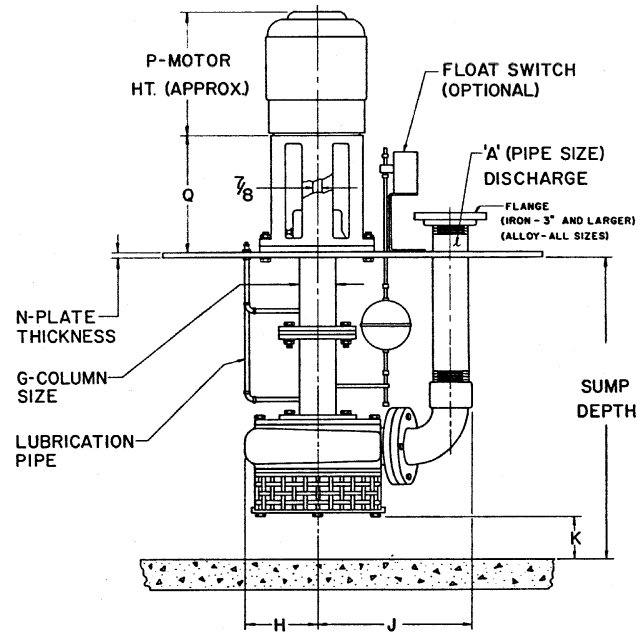

"K" dimension shown is for a pump built for a 2' through 6' pit depth. For each additional column section, subtract 3/8" from "K."

### MOTOR DATA

FRAME	P	Q
56 C	10 7/16	12
143 TC	10	12
145 TC	10 7/16	12
182 - 184 TC	13 1/2	12
213 TC	15 1/2	12
215 TC	17	12
254 TC	20 1/8	12

FRAME	P	Q
256 TC	21 1/8	12
284 TC	22 3/8	13
286 TC	23 3/8	13
324 TC	24 3/4	13 1/2
326 TC	26 1/8	13 1/2
364 TC	26 1/2	16 5/8
365 TC	27 1/2	16 5/8

Not for construction unless certified, some dimensions may vary ± 1/2". Pump Construction: \_\_\_\_\_

CUSTOMER \_\_\_\_\_ CUSTOMER NO. \_\_\_\_\_  
 PROJECT \_\_\_\_\_ SERIAL NO. \_\_\_\_\_  
 ENGINEER \_\_\_\_\_ LOCATION \_\_\_\_\_  
 CONTRACTOR \_\_\_\_\_  
 PUMP Model Size Curve No. GPM Head SP. GR. @Temp. Pump Length Plate  
 DATA \_\_\_\_\_  
 MOTOR Mfr. HP RPM Volt-Phase-Cycle Frame ENC. Furnished by Mounted by  
 DATA \_\_\_\_\_  
 Shop Order \_\_\_\_\_ Certified by \_\_\_\_\_ Date \_\_\_\_\_

## 832 Simplex Sump Pump

### PUMP DATA

SIZE	MDL	A	B	D	E	F	G	H	J	L	M	N
6x4x12	832	4							19 <sup>3</sup> / <sub>4</sub>	17		
		5	36	40	19	38	6	9	20 <sup>7</sup> / <sub>8</sub>	17 <sup>1</sup> / <sub>2</sub>	6 <sup>7</sup> / <sub>8</sub>	1/2
		6							22	18		
6x6x12	832	6	36	40	19	38	6	9 <sup>1</sup> / <sub>2</sub>	22 <sup>3</sup> / <sub>4</sub>	18 <sup>3</sup> / <sub>4</sub>	7 <sup>1</sup> / <sub>8</sub>	1/2
		8	40	54	26	52			25 <sup>1</sup> / <sub>4</sub>	19 <sup>7</sup> / <sub>8</sub>		
8x8x12	832	8	40	54	26	52	6	12 <sup>1</sup> / <sub>2</sub>	28 <sup>3</sup> / <sub>8</sub>	23	8 <sup>1</sup> / <sub>2</sub>	1/2
		10							30 <sup>3</sup> / <sub>8</sub>	24 <sup>1</sup> / <sub>8</sub>		

### MOTOR DATA

FRAME	P	Q
56 C	12 <sup>1</sup> / <sub>8</sub>	12
143 - 145 TC	12 <sup>1</sup> / <sub>4</sub>	12
182 - 184 TC	15 <sup>7</sup> / <sub>16</sub>	12
213 - 215 TC	16 <sup>11</sup> / <sub>16</sub>	14 <sup>1</sup> / <sub>4</sub>
254 - 256 TC	20	14 <sup>1</sup> / <sub>4</sub>
284 - 286 TC	20 <sup>1</sup> / <sub>8</sub>	14 <sup>5</sup> / <sub>8</sub>
324 - 326 TSC	25	16 <sup>5</sup> / <sub>8</sub>
364 - 365 TSC	25 <sup>1</sup> / <sub>4</sub>	16 <sup>5</sup> / <sub>8</sub>
404 - 405 TSC	28	18 <sup>5</sup> / <sub>8</sub>

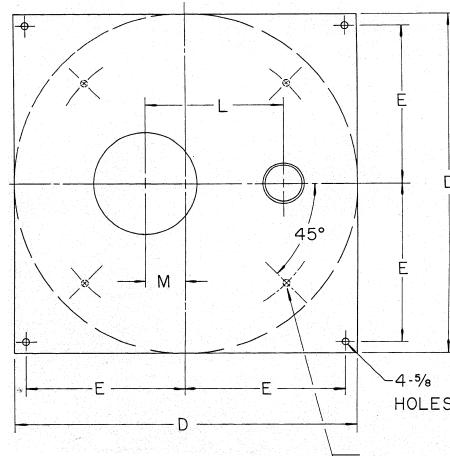
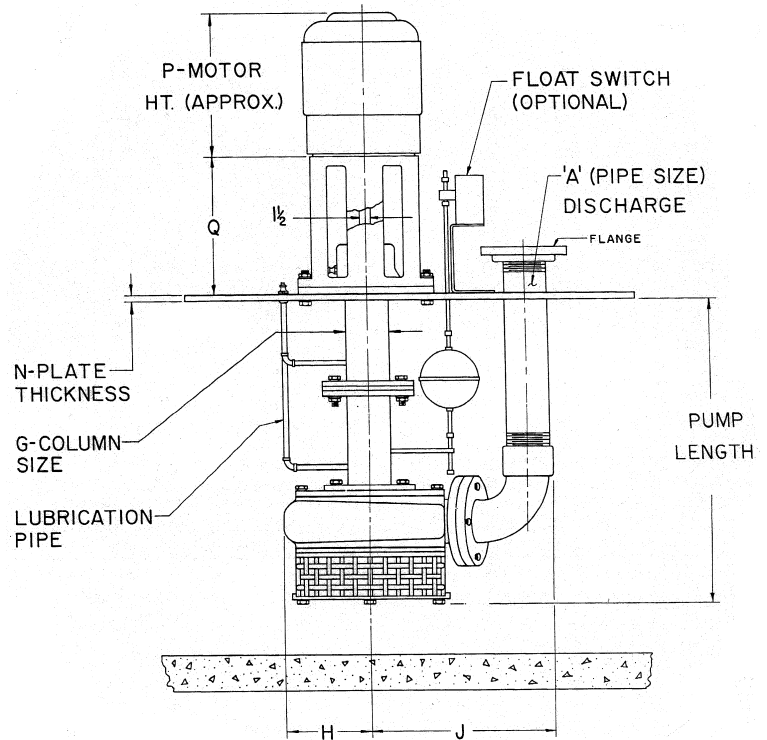

Not for construction unless certified, some dimensions may vary  $\pm 1/2"$ . Pump Construction: \_\_\_\_\_

CUSTOMER \_\_\_\_\_ CUSTOMER NO. \_\_\_\_\_  
 PROJECT \_\_\_\_\_ SERIAL NO. \_\_\_\_\_  
 ENGINEER \_\_\_\_\_ LOCATION \_\_\_\_\_  
 CONTRACTOR \_\_\_\_\_  
 PUMP Model Size Curve No. GPM Head SP. GR. @Temp. Pump Length Plate  
 DATA \_\_\_\_\_  
 MOTOR Mfg. HP RPM Volt-Phase-Cycle Frame ENC. Furnished by Mounted by  
 DATA \_\_\_\_\_  
 Shop Order \_\_\_\_\_ Certified by \_\_\_\_\_ Date \_\_\_\_\_

**VERTIFLO PUMP COMPANY**

---

*Intentionally Left Blank*