

PROJECT: _____	UNIT TAG: _____	QUANTITY: _____
REPRESENTATIVE: _____	TYPE OF SERVICE: _____	DATE: _____
ENGINEER: _____	SUBMITTED BY: _____	DATE: _____
CONTRACTOR: _____	APPROVED BY: _____	DATE: _____
	ORDER NO.: _____	DATE: _____



MTRE 10-9/9 A-WB-A-HUUV

Vertical multistage centrifugal pump with integrated frequency converter designed for tank top mounting and for pumping of cooling lubricants and cutting oils for machine tools, cooling applications, industrial liquid transfer and similar applications.

Note! Product picture may differ from actual product

Conditions of Service		Pump Data		Motor Data	
Liquid:	Emulsion	Max pressure at stated temp:	363 psi / 194 °F	Rated power - P2:	7.5 HP
Temperature:	68 °F	Liquid temperature range:	14 .. 194 °F	Rated voltage:	200-240 V
Specific Gravity:	1.000	Maximum ambient temperature:	104 °F	Mains frequency:	60 Hz
		Shaft seal:	HUUV	Enclosure class:	IP55
		Product number:	99528836	Insulation class:	F
				Motor protection:	ELEC
				Motor type:	132F
				Eta 1/1:	90.2 %

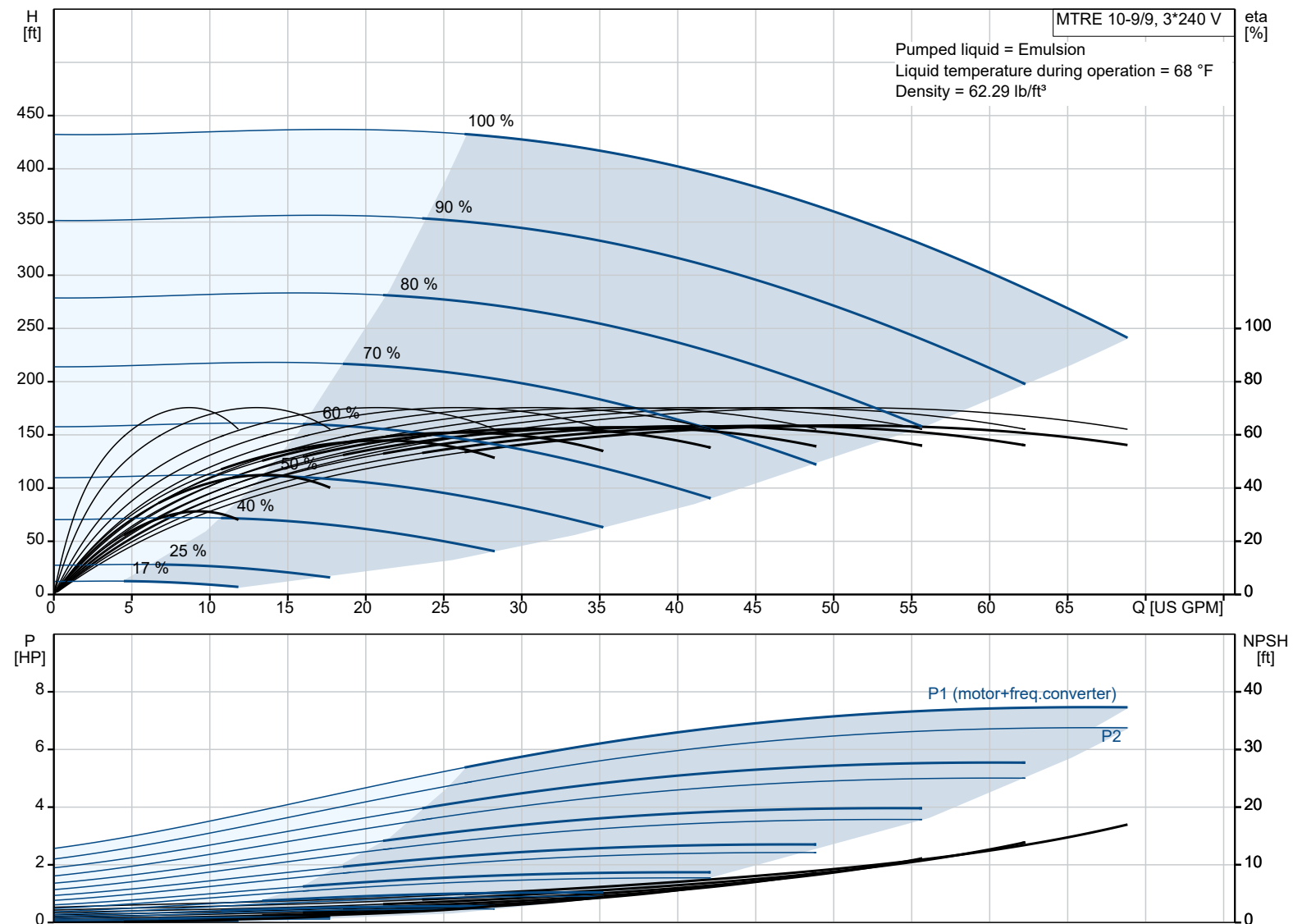

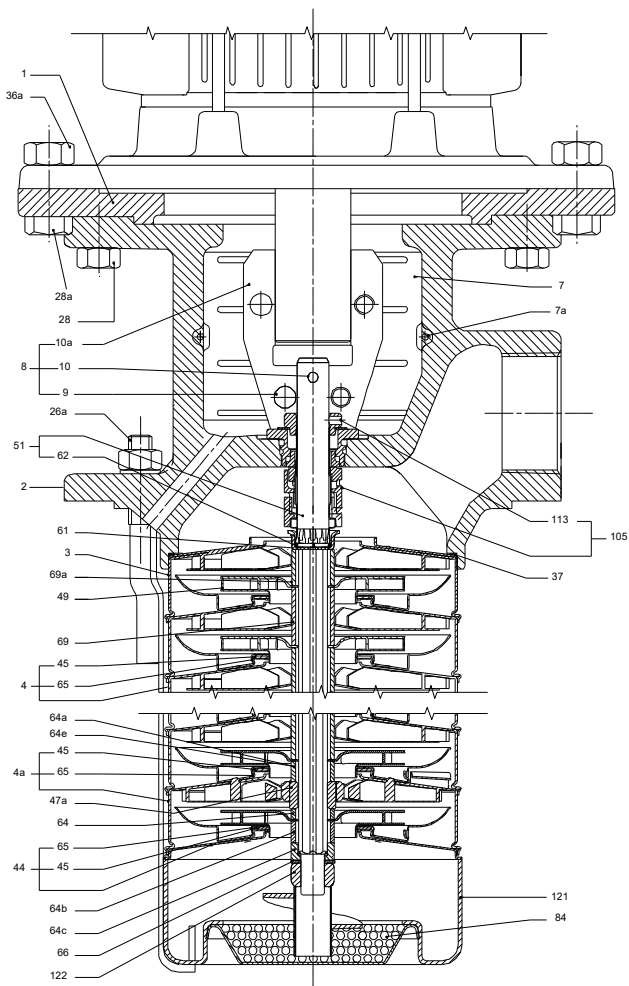
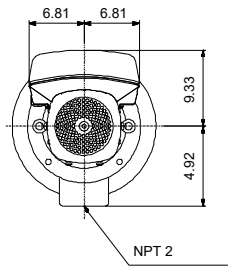
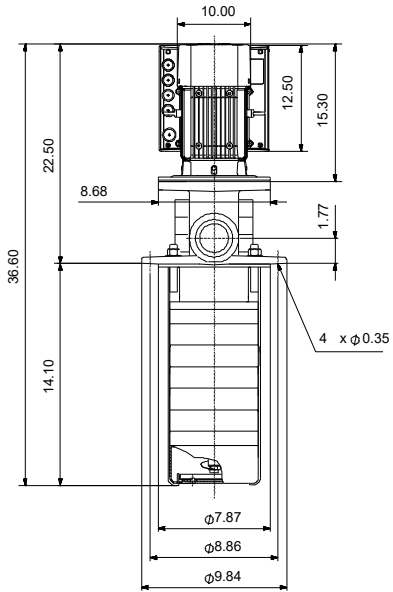

Materials:

Impeller: Stainless steel
 Impeller: AISI 304
 Impeller: EN 1.4301
 Material code: A

Qty. | Description

1 **MTRE 10-9/9 A-WB-A-HUUV**



Product No.: [99528836](#)

Multistage, immersible, self-priming, centrifugal pump for vertical installation in tanks etc.

The pump head and base are in cast iron – all other wetted parts are in stainless steel.

The pump TEST has the following characteristics:

- Dimensions according to DIN 5440.
- Impellers, intermediate chambers and spline shaft are made of Stainless steel.
- Mechanical shaft seal according to EN 12756.
- Power transmission via sintered metal split coupling.

A cartridge shaft seal ensures high reliability, safe handling, and easy access and service.

The pump is fitted with a 3-phase, fan-cooled, permanent-magnet, synchronous motor.

The motor includes a frequency converter and PI controller in the motor terminal box. This enables continuously variable control of the motor speed, which again enables adaptation of the performance to a given requirement. The operating panel on the motor terminal box features a four-inch TFT display, push-buttons and the Grundfos Eye indicator.

The display gives an intuitive and user-friendly interface to all functions.

The push-buttons are used to navigate through the menu structure to access pump and performance data on site and enable setting of required setpoint as well as setting of pump to "Min." or "Max." operation or to "Stop".

The Grundfos Eye indicator on the operating panel provides visual indication of pump status:

- "Power on": Motor is running (rotating green indicator lights) or not running (permanently green indicator lights)
- "Warning": Motor is still running (rotating yellow indicator lights) or has stopped (permanently yellow indicator lights)
- "Alarm": Motor has stopped (flashing red indicator lights).

Communication with the pump is also possible by means of Grundfos GO Remote (accessory). The remote control enables further settings as well as reading out of a number of parameters such as "Actual value", "Speed", "Power input" and total "Power consumption".

The terminal box has a number of inputs and outputs enabling the motor to be used in advanced applications where many inputs and outputs are required:

- two dedicated digital inputs
- three analog inputs, 0(4)-20 mA, 0-5 V, 0-10 V, 0.5-3.5 V
- 5 V voltage supply to potentiometer and sensor
- one analog output, 0-10 V, 0(4)-20 mA
- two configurable digital inputs or open-collector outputs
- two Pt100/Pt1000 inputs
- LiqTec, dry-running protection sensor input
- Grundfos Digital Sensor input and output
- 24 V voltage supply for sensors
- two signal-relay outputs (potential-free contacts)
- GENIbus connection
- interface for Grundfos CIM fieldbus module.

Immersion depth: 14.1 in

Controls:

Frequency converter: Built-in

Liquid:

Pumped liquid: Emulsion

Liquid temperature range: 14 .. 194 °F

Selected liquid temperature: 68 °F

Density: 62.29 lb/ft³

Technical:

Pump speed on which pump data are based: 3467 rpm

Rated flow: 53.3 US GPM

Rated head: 341.6 ft

Qty.	Description
1	<p>Chambers: 9</p> <p>Drainage back to tank: N</p> <p>Pump orientation: Vertical</p> <p>Code for shaft seal: HUUU</p> <p>Approvals: CE,UKCA,RCM,cURus/cCSAus</p> <p>Approvals for motor: CE, RCM, cURus, IE5, IES2,UKCA, SEPRO</p> <p>Energy approvals for motor: CE</p> <p>Curve tolerance: ISO9906:2012 3B</p> <p>Cable gland entry: 1 x NPT 3/4" + 5 x NPT 1/2"</p> <p>Materials:</p> <p>Pump head: Cast iron EN 1561 EN-GJL-200 ASTM A48-25B</p> <p>Impeller: Stainless steel EN 1.4301 AISI 304</p> <p>Installation:</p> <p>Maximum ambient temperature: 104 °F</p> <p>Maximum operating pressure: 362.59 psi</p> <p>Max pressure at stated temp: 363 psi / 194 °F</p> <p>Type of connection: NPT(F)</p> <p>Size of outlet connection: 2 inch</p> <p>Immersion depth: 14.1 in</p> <p>Flange size for motor: 213TC</p> <p>Electrical data:</p> <p>Motor standard: NEMA</p> <p>Motor type: 132F</p> <p>Rated power - P2: 7.5 HP</p> <p>Mains frequency: 60 Hz</p> <p>Suitable for 50/60 Hz: N</p> <p>Rated voltage: 3 x 200-240 V</p> <p>Service factor: 1.15</p> <p>Rated current: 20.0-16.6 A</p> <p>Cos phi - power factor: 0.94</p> <p>Rated speed: 360-4000 rpm</p> <p>IE Efficiency class: IE5</p> <p>Motor efficiency at full load: 90.2 %</p> <p>Enclosure class (IEC 34-5): IP55</p> <p>Insulation class (IEC 85): F</p> <p>Motor No: 99301703</p> <p>Others:</p> <p>Terminal box position: 6</p> <p>Minimum efficiency index, MEI ≥: 0.70</p> <p>Net weight: 147 lb</p> <p>Gross weight: 210 lb</p> <p>Shipping volume: 16.9 ft³</p>

99528836 MTRE 10-9/9 A-WB-A-HUUV 60 Hz

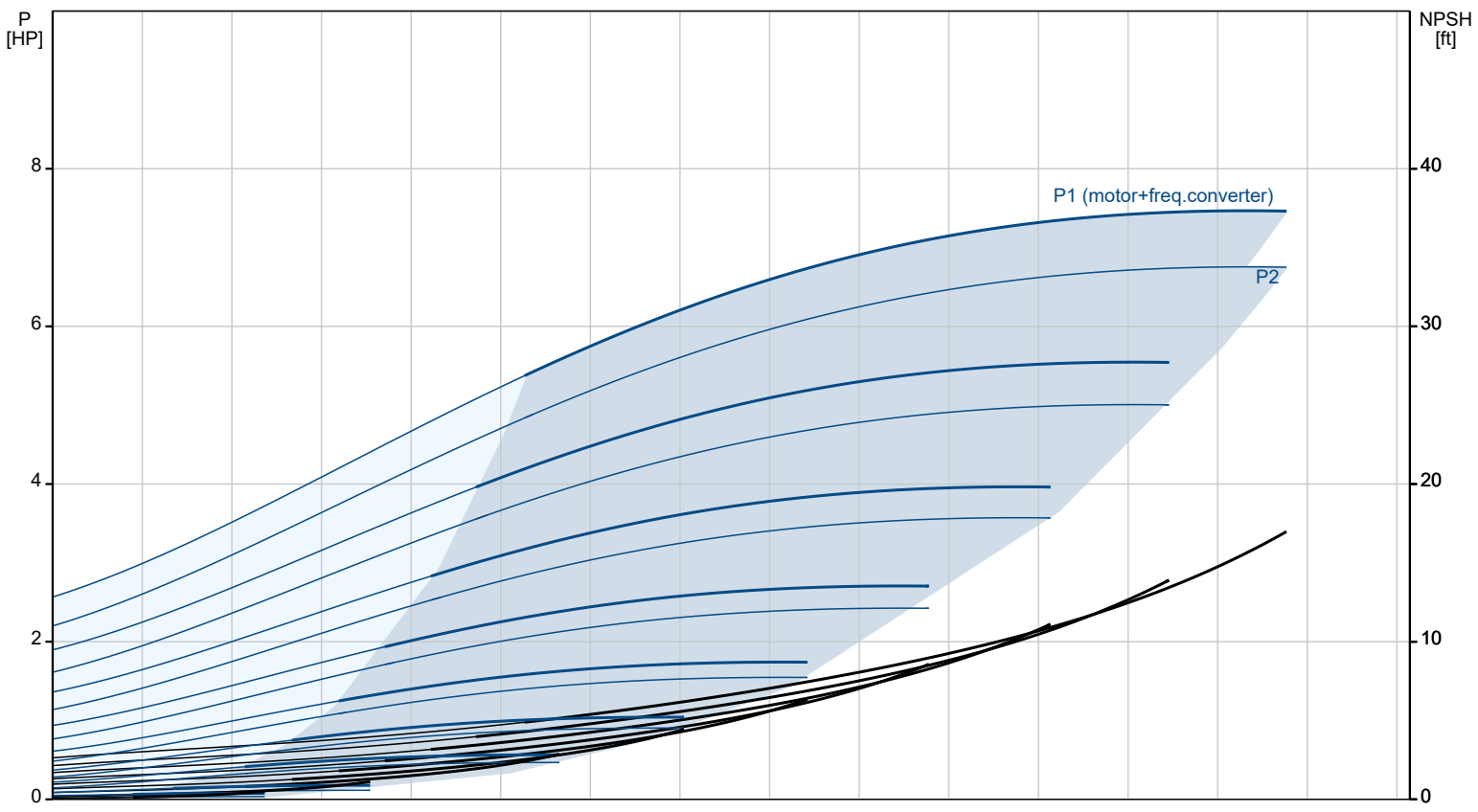
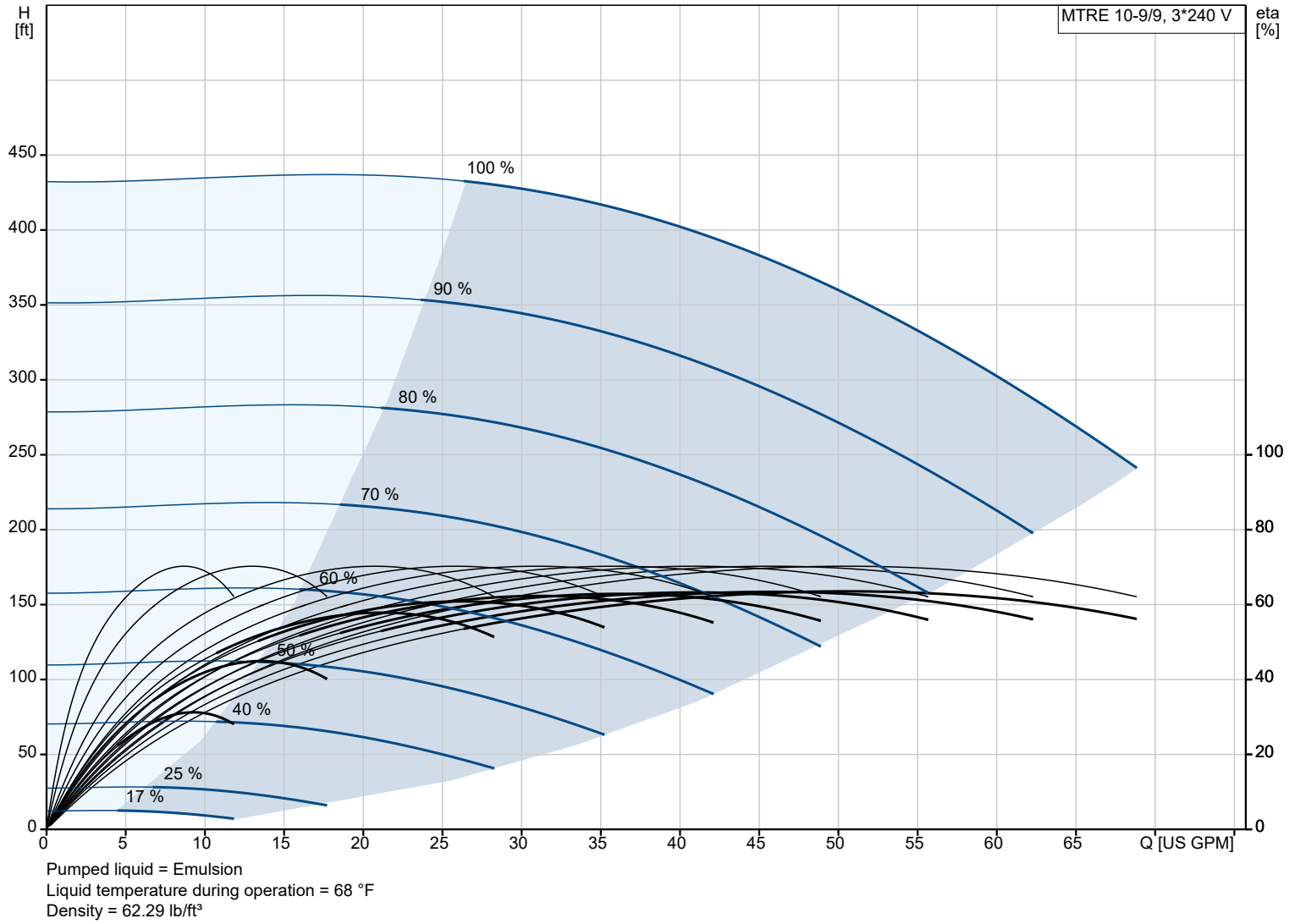

Description	Value
General information:	
Product name:	MTRE 10-9/9 A-WB-A-HUUUV
Product No:	99528836
EAN number:	5713830566244
Technical:	
Pump speed on which pump data are based:	3467 rpm
Rated flow:	53.3 US GPM
Rated head:	341.6 ft
Chambers:	9
Impellers:	9
Number of reduced-diameter impellers:	0
Drainage back to tank: N	
Pump orientation:	Vertical
Code for shaft seal:	HUUUV
Approvals:	CE,UKCA,RCM,cURus/cCSAus
Approvals for motor:	CE, RCM, cURus, IE5, IES2,UKCA, SEPRO
Energy approvals for motor:	CE
Curve tolerance:	ISO9906:2012 3B
Pump version:	A
Model:	A
Cable gland entry:	1 x NPT 3/4" + 5 x NPT 1/2"
Materials:	
Pump head:	Cast iron
Pump head:	EN 1561 EN-GJL-200
Pump head:	ASTM A48-25B
Impeller:	Stainless steel
Impeller:	EN 1.4301
Impeller:	AISI 304
Material code:	A
Installation:	
Maximum ambient temperature:	104 °F
Maximum operating pressure:	362.59 psi
Max pressure at stated temp:	363 psi / 194 °F
Type of connection:	NPT(F)
Size of outlet connection:	2 inch
Immersion depth:	14.1 in
Flange size for motor:	213TC
Connect code:	WB
Liquid:	
Pumped liquid:	Emulsion
Liquid temperature range:	14 .. 194 °F
Selected liquid temperature:	68 °F
Density:	62.29 lb/ft³
Electrical data:	
Motor standard:	NEMA
Motor type:	132F
Rated power - P2:	7.5 HP
Mains frequency:	60 Hz
Suitable for 50/60 Hz:	N
Rated voltage:	3 x 200-240 V
Service factor:	1.15
Rated current:	20.0-16.6 A
Cos phi - power factor:	0.94
Rated speed:	360-4000 rpm
IE Efficiency class:	IE5
Motor efficiency at full load:	90.2 %
Enclosure class (IEC 34-5):	IP55
Insulation class (IEC 85):	F
Built-in motor protection:	ELEC
Motor No:	99301703
Controls:	
Control panel:	Graphical
Function Module:	FM300 - Advanced

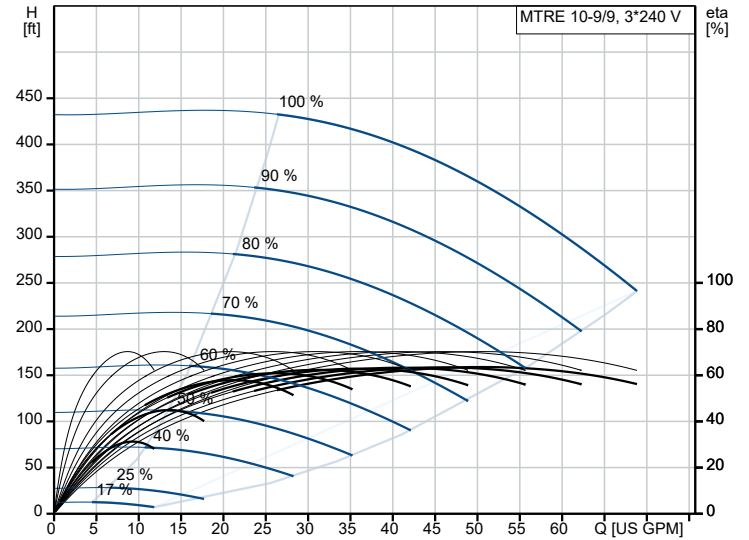

Pumped liquid = Emulsion
 Liquid temperature during operation = 68 °F
 Density = 62.29 lb/ft³

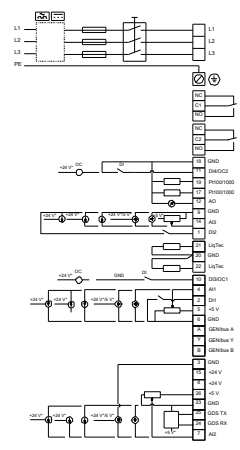
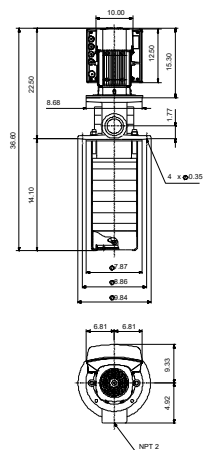
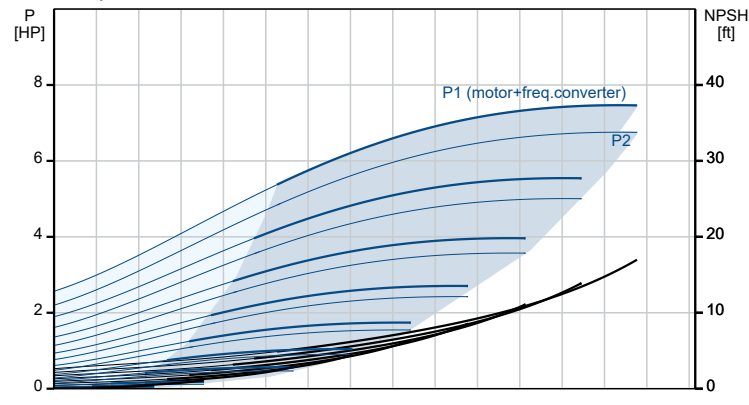



Company name:

Created by:

Phone:

Date:

24/04/2024

Description	Value
Frequency converter:	Built-in
Others:	
Terminal box position:	6
Minimum efficiency index, MEI ≥:	0.70
Net weight:	147 lb
Gross weight:	210 lb
Shipping volume:	16.9 ft ³

99528836 MTRE 10-9/9 A-WB-A-HUUV 60 Hz

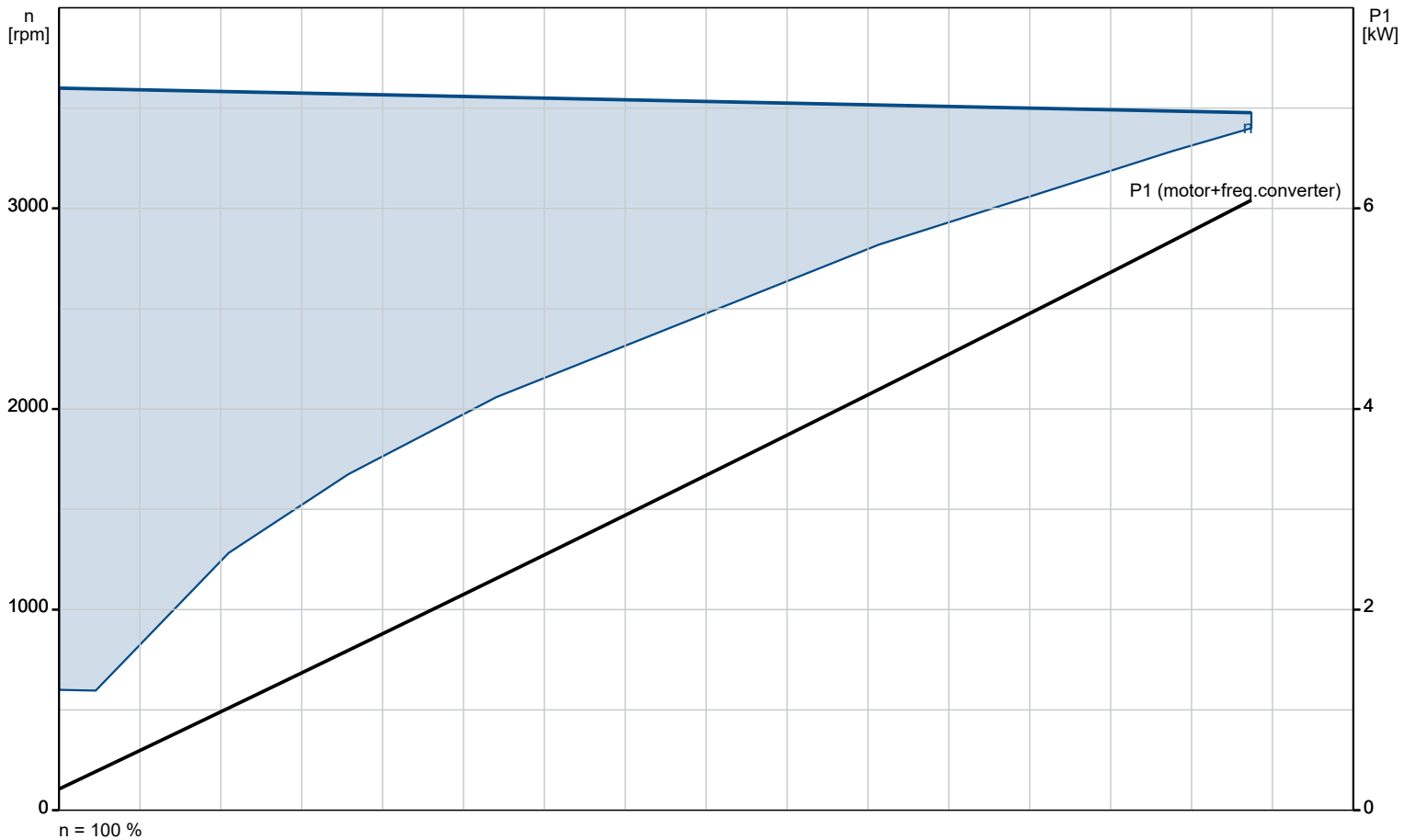
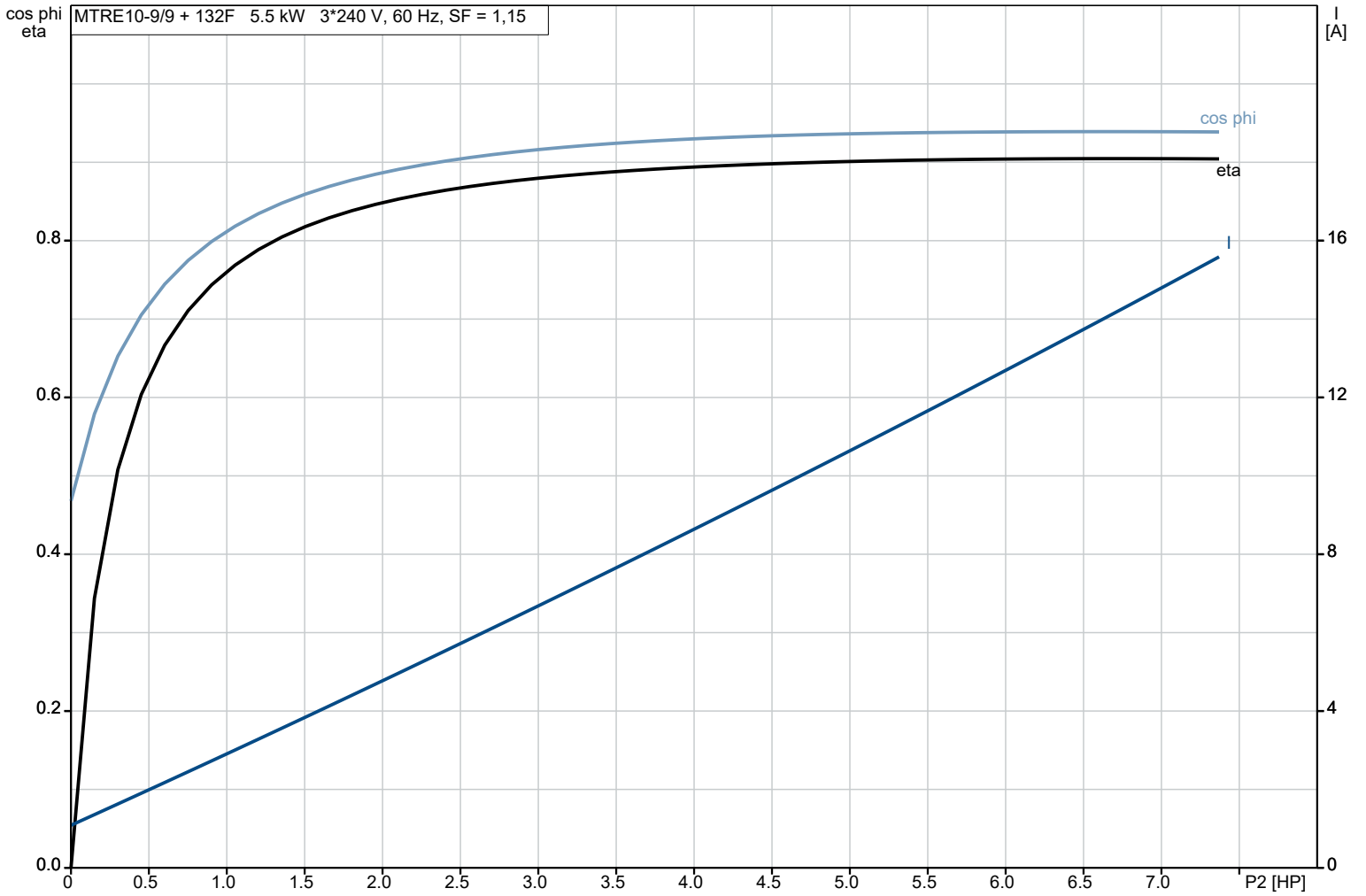

99528836 MTRE 10-9/9 A-WB-A-HUUV 60 Hz

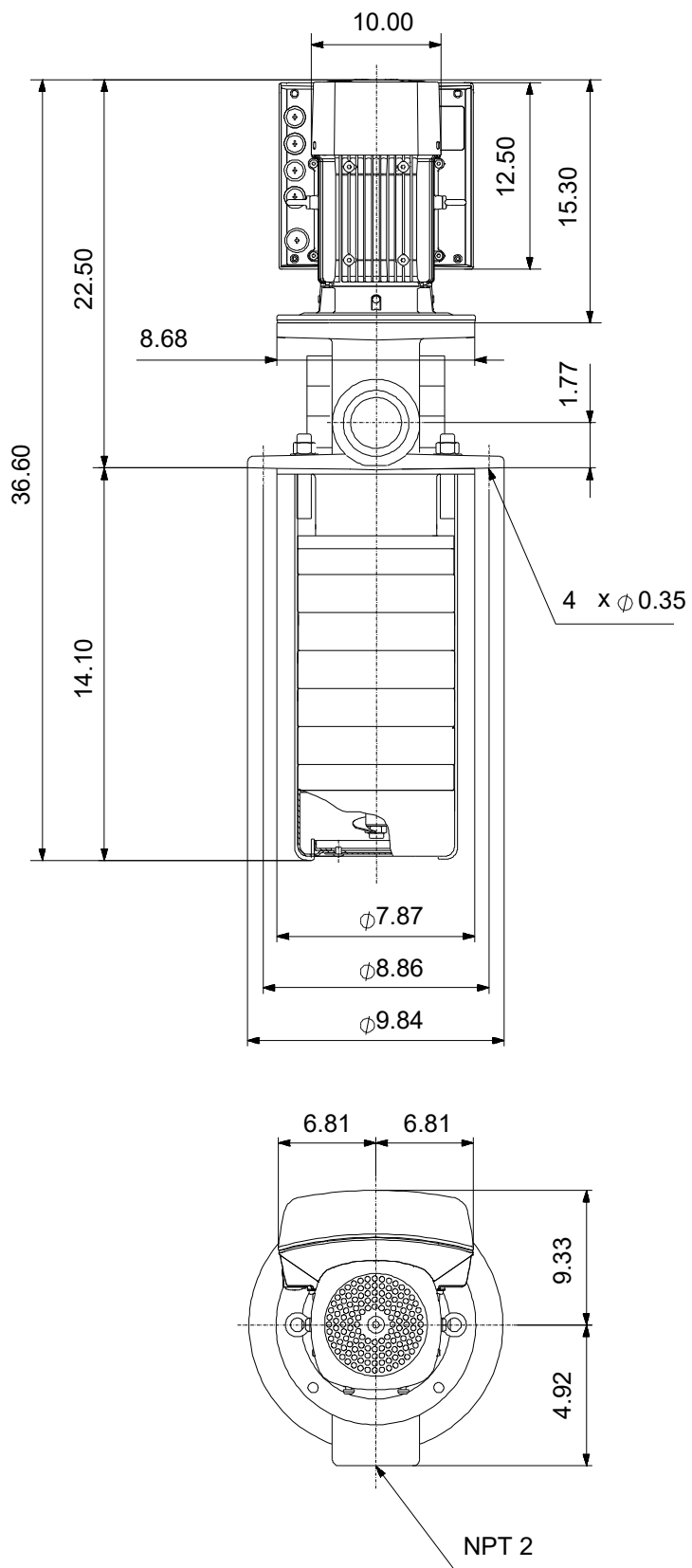

99528836 MTRE 10-9/9 A-WB-A-HUUV 60 Hz

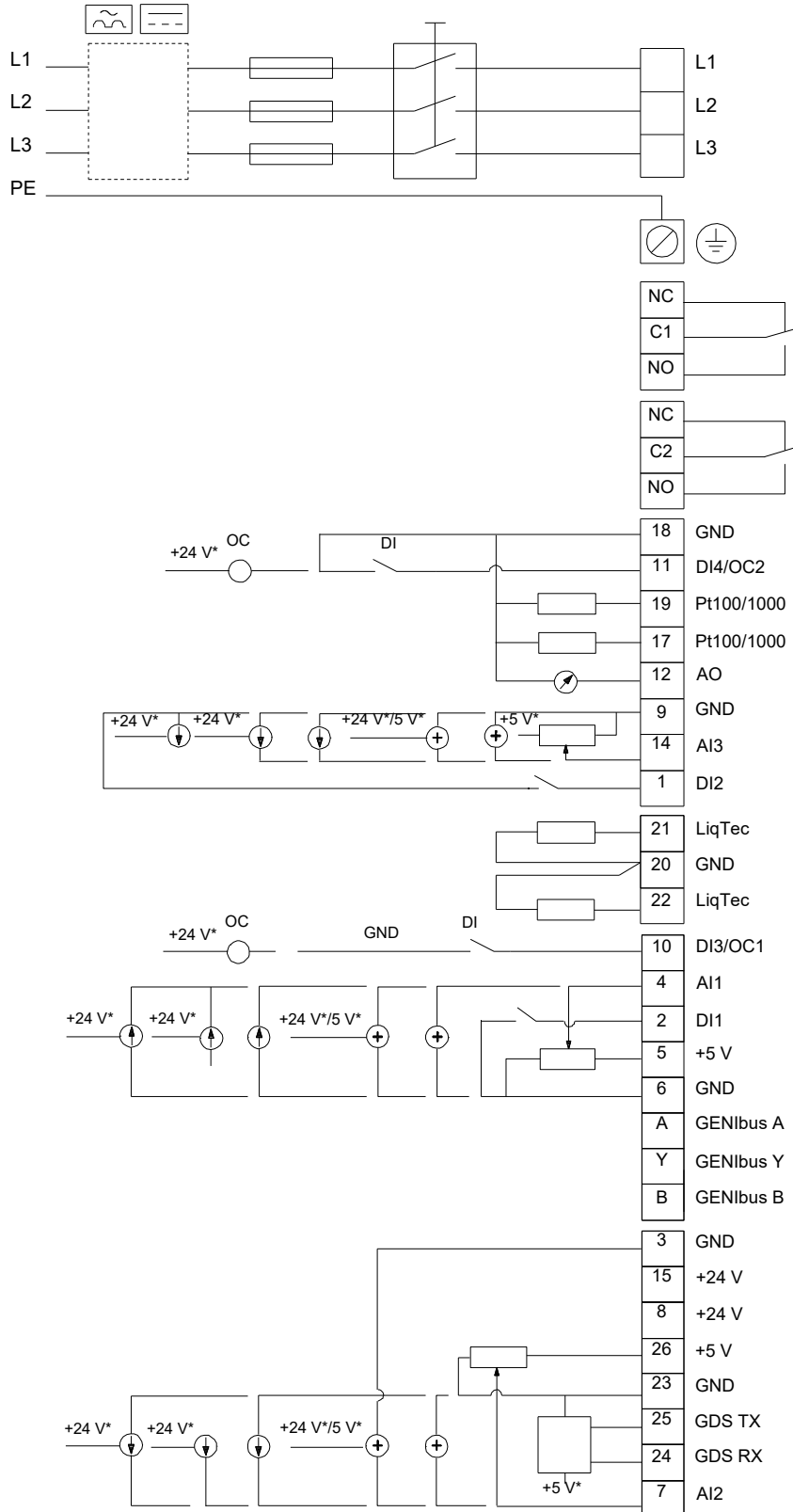

Note! All units are in [in] unless others are stated.