

E-BCB Series

Filter Bag Housings

w/ Economical Band Clamp Closure

EndoerTM
Leading Filtration into the Future

Manufactured of AISI304 or AISI316L stainless steel for high-purity industrial filtration requirements. Single-bag housings accept standard Size #1 or Size #2 bags. Multiple options for porting type. Provided standard with drain port, vent port, and upstream & downstream gauge ports.

Features

- Convenient band-clamp closure allows easy access for bag change-out.
- Simplified design provides better economy versus swing bolt styles.
- Adjustable leg assembly offers installation flexibility.
- 150 psi (10 bar) operating pressure rating.
- Can provide flow rates up to 200 GPM.
- Surface passivation reduces potential for weld line corrosion.
- Includes drain and gauge ports on both the clean and dirty sides.

Applications

- Suitable for the broadest range of industrial applications from process fluid streams for water, aqueous solutions, oils, and fine chemicals.
- Used in food and beverage production: filtration of juices, syrups, food ingredients, and bottled water.

Product Quality

- Manufactured within an ISO 9001:2015 certified quality management system.
- Halal certified.
- Certification of Quality document can be provided upon request.



Certified to NSF/ANSI/CAN 61 for material safety requirements only.

Certification includes only the "E", "B", and "S" seal options, and for use temperature to 86° F.

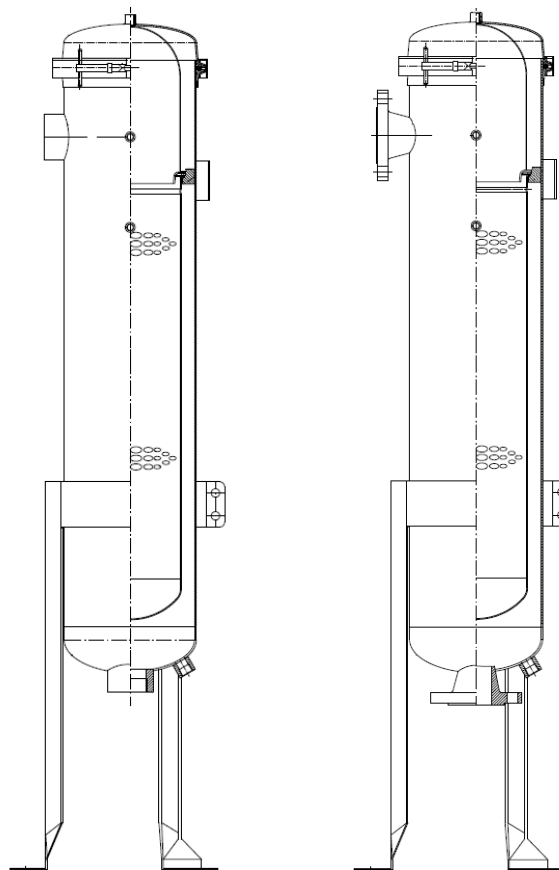

E-BCB-S2x1-2FN

E-BCB-S2x1-2F

Materials of Construction

Shell Components:	AISI304 or AISI316L Stainless Steel
Seal Options:	EPDM (standard), NBR, SILICONE, FKM

Surface Finish

Surface Quality:	Glass beaded finish is standard
	Industrial electropolish is optional

Operating Conditions

Operating Temperature:	121°C (250°F) max.
Design Pressure:	10 bar (150 psi)

Ordering Information

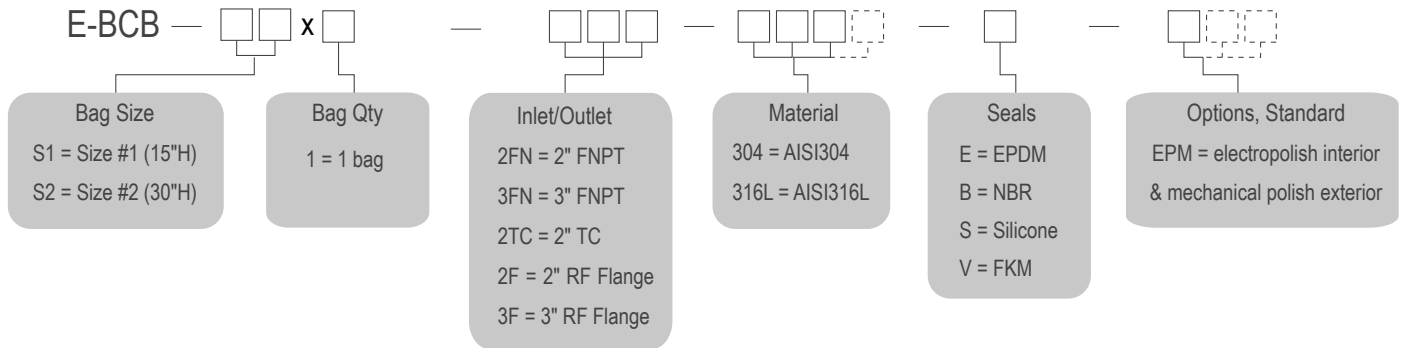

Note: Other port sizes, pressure ratings, and optional constructions may be available. Please inquire.

To order or for technical assistance, please contact:

Endoer Filtration Inc.

629 14th SW, Loveland, CO 80537 USA

tel: +1.970.398.4667

toll-free: +1.877.317.2503

fax: +1.970.230.5918

sales@endoerfiltration.com

www.endoerfiltration.com

DISCLAIMER: The filtration data presented is representative of performance characterized in a laboratory setting. The data is not offered as a warranty, specification, or statement of fitness for a specific application. Performance can vary greatly depending on the fluid, contaminants present, flow conditions, and operating environment. Users are advised to conduct comprehensive qualification testing to substantiate that the product performs as required.

See the applicable Product Performance & Operating Guide for additional information on the function and capabilities of the product.

Endoer Filtration Inc.

TDS-BCB-250501

Copyright © 2025 Endoer Filtration Inc. All rights reserved.