



66SVX21GMAXX0

Created On: 1/19/26

66SVX21GMAXX0 | Configuration Summary



e-SVX Smart Pumps integrate decades of expertise and know-how in pump technology to bring the right combination of motors, variable speed drive and hydraulic pumps in one comprehensive, highly efficient package. The e-SVX is built to withstand a variety of mechanically aggressive and high temperature liquids such as glycol, oils/solvents, and more. It features 10 different sizes and each can be specially configured for a wide range of environments. It's an ideal solution for residential, light commercial, industrial, agricultural, and OEM water supply as well as HVAC applications.

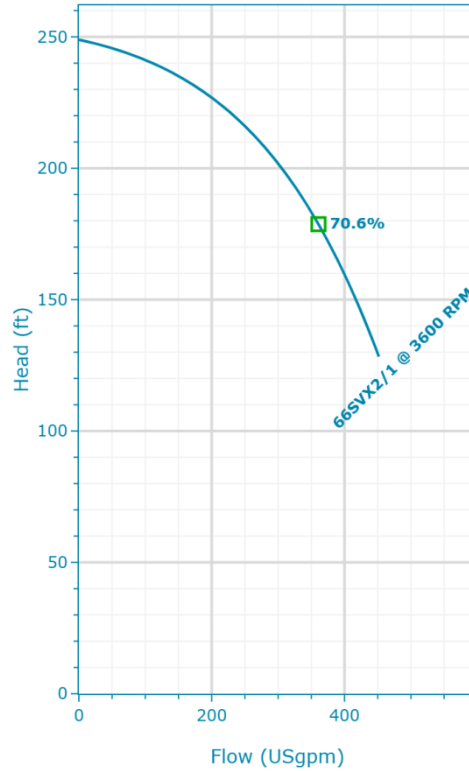

PUMP

Installation	Pump Size
Complete Pump	33-92SV

MATERIALS

Pump Body Material	Impeller Material
Cast Iron (ASTM Class 35/40B)	Stainless Steel

SEAL

Type of Seal	Rotating Face
Mechanical Seals	Carbon
	Stationary Face
	Silicon Carbide Graphite Filled
	Elastomers
	Viton
	Spring
	316 SS
	Metal Components
	316 SS

STANDARD OPTIONS

Special Configuration	Additional Configuration
Please Select	Please Select

MOTOR

Frequency (Hz)	Power
60	25 hp
Poles	Phase (~)
4	3
Enclosure	Voltage
TEFC	380-480 V
Frame Size	
250TC	

FLANGE

Flange
[G] = Round Flanges (AISI 304/Cast Iron)

66SVX21GMAXX0 | Product Details

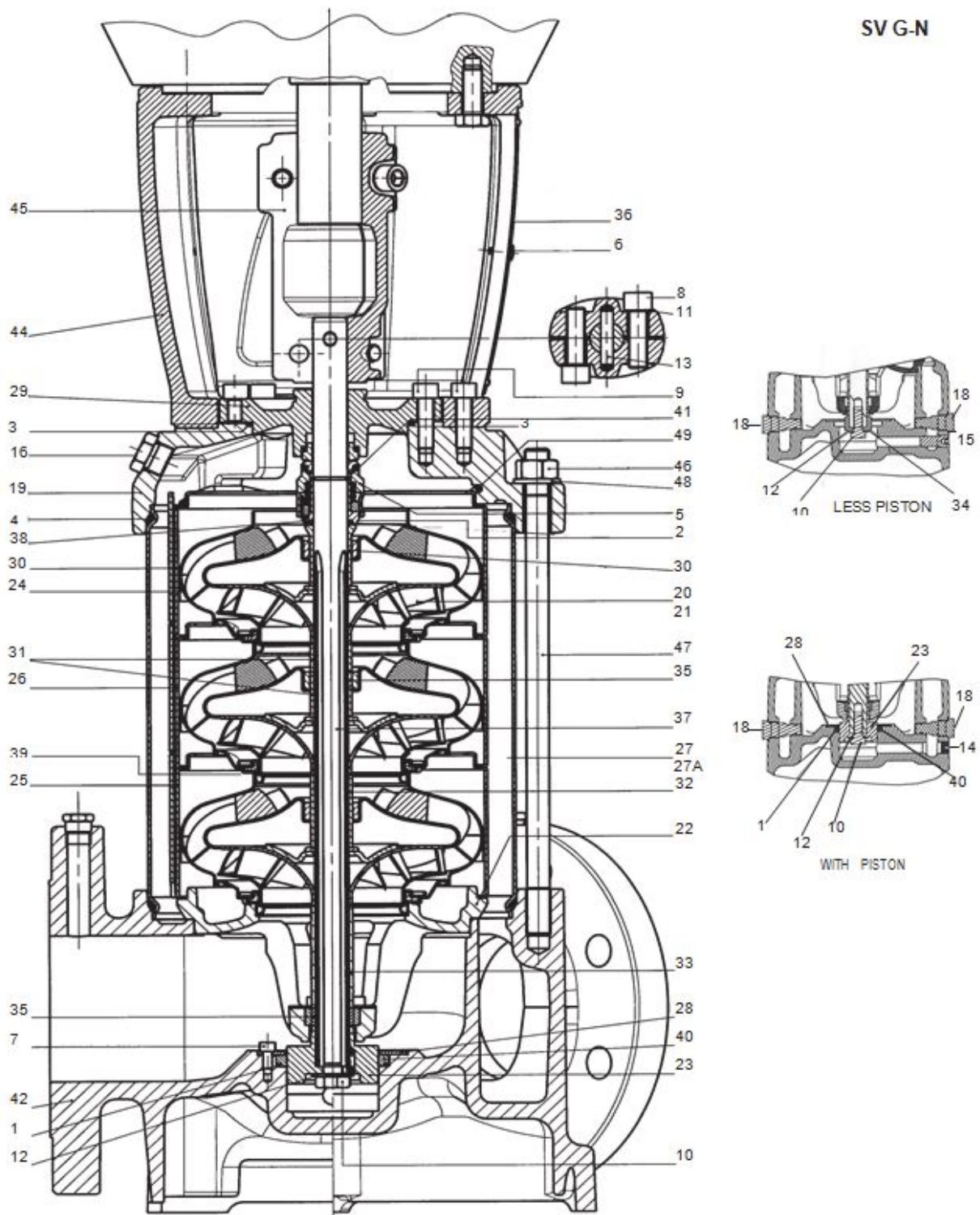

SV G-N

Construction Materials

O-Ring, Piston Seal (1) Viton (std) EPDM (opt)	Mechanical Seal (5) See Mechanical Section	Screw, Coupling (8) Zinc Plated Steel / B363	Washer, Impeller (12) Stainless Steel / A193-316
O-Ring, Mechanical Seal Sleeve (2) See Mechanical Section	Cartridge Seal (not shown) (5A) See Seal Materials Chart for Complete Detail	Screw, MA and Seal Housing (9) Zinc Plated Steel / B633	Pin, Coupling (13) Carbon Steel / A108
O-Ring, Seal housing (3) Viton (std) EPDM (opt)	Screw, Guard (6) Stainless Steel / A193-304	Screw, Impeller (10) Stainless Steel / A193-316	Plug, with Piston (14) Stainless Steel / A193-316
O-Ring, Sleeve (4) Viton (std) EPDM (opt)	Screw, Piston Holding Disc (7) Stainless Steel / A193-316	Washer, Coupling (11) Carbon Steel / A108	Plug, without Piston (15) Stainless Steel / A193-316

Plug, Fill (16) Stainless Steel/O-Ring / A193-316	Impeller, Full Diameter (20) Stainless Steel / A193-316L	Diffuser, Final (24) Stainless Steel / A193-316L	Outer Sleeve, 40 Bar (27A) Stainless Steel / A193-316L
Plug, Vent (not shown) (17) Stainless Steel/O-Ring / A193-316	Impeller, Reduced Diameter (21) Stainless Steel / A193-316L	Diffuser with Carbon Bushing (25) Stainless Steel / A193-316L	Holding Disc, Piston Seal (28) Stainless Steel / A193-316L
Plug, Drain (18) Stainless Steel/O-Ring / A193-316	Lower Bearing Assembly (22) SS/Cast Iron / A193-316L/A48 Class 35	Diffuser with Tungsten Bushing (26) Stainless Steel / A193-316L	Seal Housing (29) Cast Iron / A48 Class 35
Pump Head (19) Cast Iron / A48 Class 35	Piston (23) Duplex SS / A182-F51	Outer Sleeve, 25 Bar (27) Stainless Steel / A193-316L	Spacer, Impeller Final (30) Stainless Steel / A193-316
Spacer, Shaft Bushing (31) Stainless Steel / A193-316	Tungsten Carbide Bushing (35) Tungsten Carbide	Wear Ring, Impeller (39) PPS Glass Filled	Motor Adapter Plate (not shown) (43) Cast Iron / A48 Class 25
Spacer, Impeller (32) Stainless Steel / A193-316	Coupling Guard (36) Stainless Steel / A193-304	Piston Seal (40) Impregnated Carbon	Motor Adapter (44) Cast Iron / A48 Class 25
Spacer, Impeller Lower (66-92SV) (33) Stainless Steel / A193-316	Shaft (37) Duplex SS / A182-F51	Stop Ring, Impeller (41) Stainless Steel / A193-316	Coupling, Half (45) Cast Iron / A48 Class 25
Bushing, Non-Piston (34) Stainless Steel / A193-316	Mechanical Seal Shaft Sleeve (38) Stainless Steel / A193-316	Pump Body (42) Cast Iron / A48 Class 35	Nut, Tie-Rod (46) Zinc Plated Steel / B633
			Tie-Rod (47) Zinc Plated Steel / B633
			Washer, Tie-Rod (48) Zinc Plated Steel / B633
			Spring, Final Diffuser (49) Stainless Steel / A193-316

Motor

Enclosure TEFC	Rated Voltage 380-480 V	Phase 3	SLA 33.5-28.6
Rated Power 25 Hp	Frame Size 250TC	FLA 33.5-28.6	Service Factor 1

66SVX21GMAXX0 | Hydraulic Data & Performance Curve

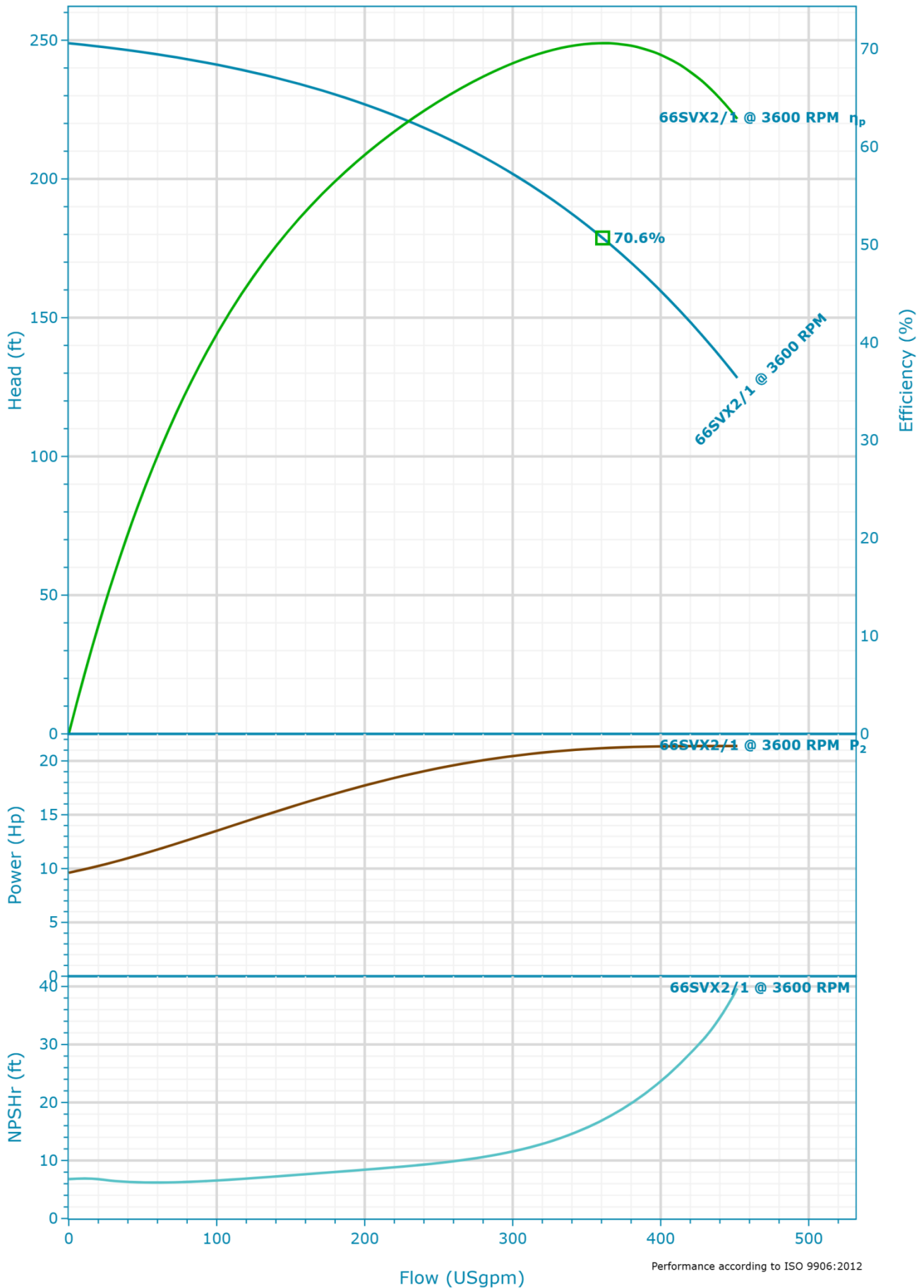

Selection

Series Standby Pumps
e-SVX No Standby Pump

Name
66SVX2/1 3600rpm

Stages
2

Frequency
60 Hz

Acceptance Grade
Manufacturer's Standard

System Type
Single Pump

Operating Pumps
1

Fluid and Operating Conditions

Fluid Type Density
Water 62.43 lb/ft³

Fluid Temperature Dynamic Viscosity
39.2 °F 1.57 cP

Specific Gravity Fluid Vapor Pressure
1 0.12 psi

Atmospheric Pressure
14.7 psi

Elevation
0 ft

Ambient Temperature
68 °F

NPSH Available
33.68 ft

Submergence
0 ft

Design Curve

Rated Speed BEP Flow
3,600 RPM 360.78 USgpm

Max Flow BEP Head
451.8 USgpm 178.73 ft

H@QMin Max Operating Pressure
248.9 ft 107.75 psi

H@QMax Max P2
128.3 ft 21.39 Hp

BEP
70.58 %

66SVX21GMAXX0 | Dimensional Data & Drawing

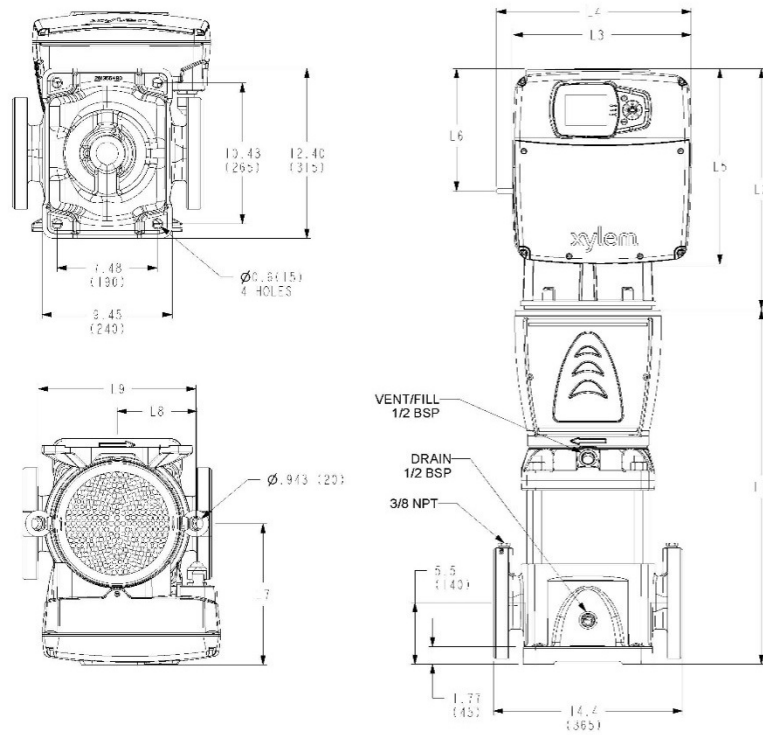

Drawing is preliminary and is subject to change.

Dimensions

L1	L5	L9
26.75 in	15.72 in	12.5 in
L2	L6	Weight (Pump Only)
19.29 in	9.57 in	196 lbs
L3	L7	Weight (Motor Only)
14.25 in	12.17 in	174 lbs
L4	L8	Total Weight
15.16 in	6.59 in	370 lbs

Company	PFC Equipment
Contact	Corey Nath
Phone No.	7634257890
Email	cnath@pfcequip.com