

Submittal Data

PROJECT:	UNIT TAG:	QUANTITY:
REPRESENTATIVE: _____	TYPE OF SERVICE:	DATE: _____
ENGINEER:	SUBMITTED BY:	DATE:
CONTRACTOR:	APPROVED BY:	DATE:
	ORDER NO.:	DATE:



CR 32-2-1 A-G-A-E-HQQE

Vertical, multistage centrifugal pump with suction and discharge ports on the same level. The pump head and base are in cast iron - all other wetted parts are in stainless steel (EN 1.4301)

Note! Product picture may differ from actual product

Conditions of Service		Pump Data		Motor Data	
Liquid:	Water	Max pressure at stated temp:	16 bar / 120 °C	Rated power - P2:	5.5 kW
Temperature:	20 °C	Liquid temperature range:	-30 .. 120 °C	Rated voltage:	208-230 V
Specific Gravity:	1.000	Maximum ambient temperature:	40 °C	Mains frequency:	60 Hz
		Shaft seal:	HQQE	Enclosure class:	IP55
		Product number:	99917930	Insulation class:	F
				Motor protection:	NONE
				Motor type:	WEG
				Eta 1/1:	84.0 %

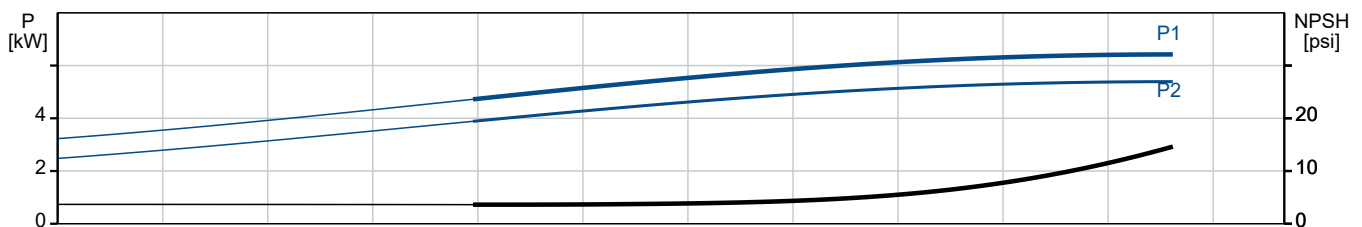
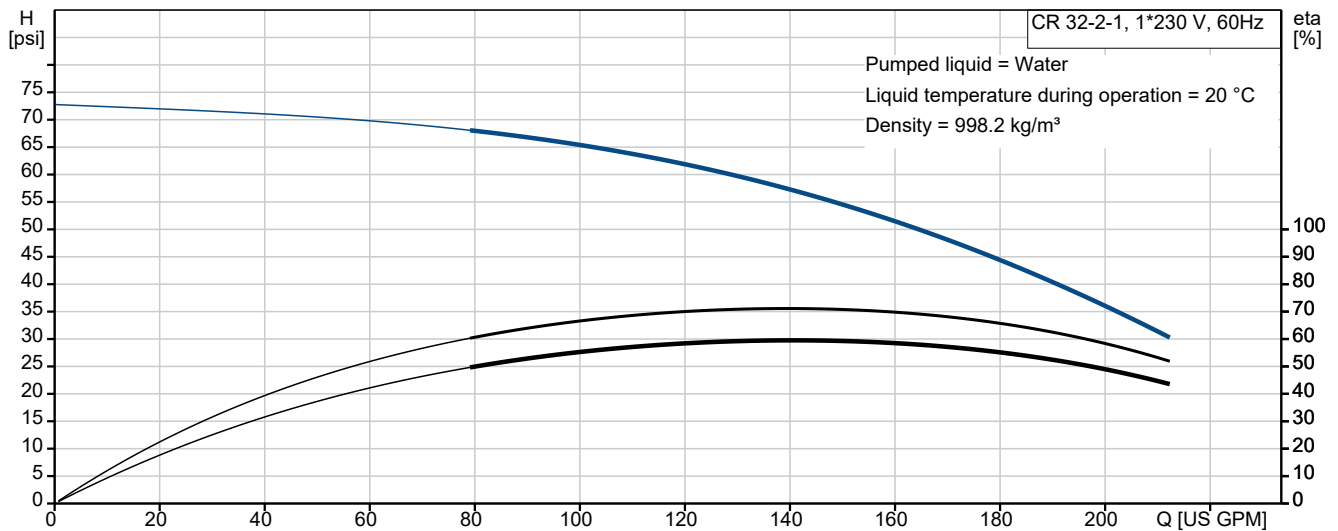

Submittal Data

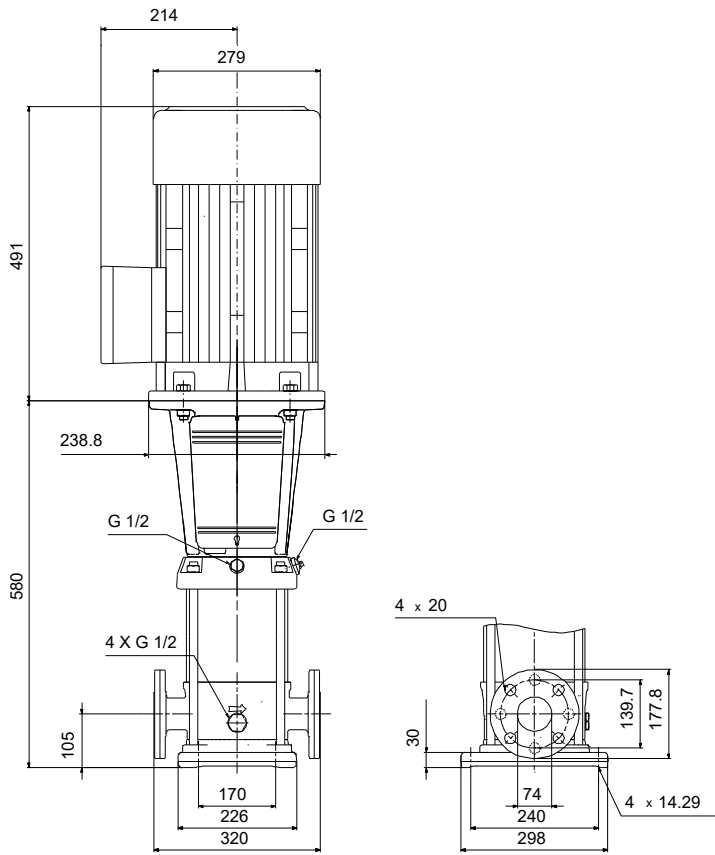

Materials:

- Base: Cast iron
EN 1563 EN-GJS-500-7
ASTM A536 80-55-06
- Impeller: Stainless steel
AISI 304
EN 1.4301
- Material code: A
- Code for rubber: E

Qty. Description

1 CR 32-2-1 A-G-A-E-HQQE



Note! Product picture may differ from actual product

Product No.: [99917930](#)

Vertical, multistage centrifugal pump with inlet and outlet ports on same the level (inline). The pump head and base are in cast iron – all other wetted parts are in stainless steel. A cartridge shaft seal ensures high reliability, safe handling, and easy access and service. Power transmission is via a rigid split coupling. Pipe connection is via ANSI flanges.

The pump is fitted with a 1-phase, fan-cooled asynchronous motor.

Further product details

Steel, cast iron and aluminium components have an epoxy-based coating made in a cathodic electro-deposition (CED) process.

CED is a high-quality dip-painting process where an electrical field around the products ensures deposition of paint particles as a thin, well-controlled layer on the surface.

An integral part of the process is a pretreatment.

The entire process consists of these elements:

- 1) Alkaline-based cleaning.
- 2) Zinc phosphating.
- 3) Cathodic electro-deposition.
- 4) Curing to a dry film thickness 18-22 my m.

The colour code for the finished product is NCS 9000/RAL 9005.

Pump

A standard split coupling connects the pump and motor shaft. It is enclosed in the pump head/motor stool by means of two coupling guards.

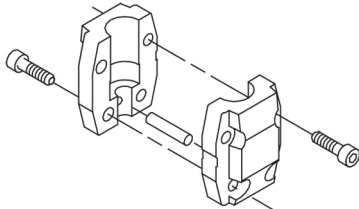

The motor stool connects the pump head and motor. The pump head has a combined 1/2" priming plug and vent screw.

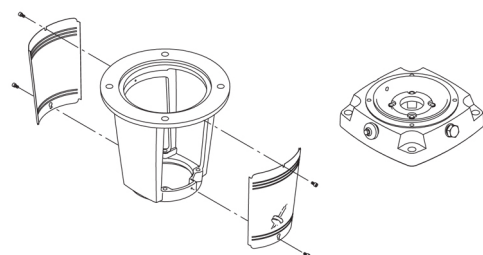

Qty. Description

1 The pump is fitted with a balanced O-ring seal unit with a rigid torque-transmission system. This seal type is assembled in a cartridge unit which makes replacement safe and easy. Due to the balancing, this seal type is suitable for high-pressure applications. The cartridge construction also protects the pump shaft from possible wear from a dynamic O-ring between pump shaft and shaft seal.

Seal faces:

- Rotating seal ring material: silicon carbide (SiC)
- Stationary seat material: silicon carbide (SiC)

This material pairing is used where higher corrosion resistance is required. The high hardness of this material pairing offers good resistance against abrasive particles.

Secondary seal material: EPDM (ethylene-propylene rubber)
EPDM has excellent resistance to hot water. EPDM is not suitable for mineral oils.

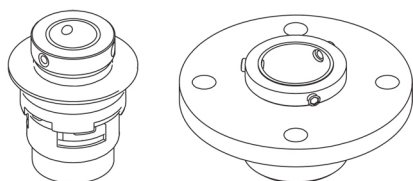

The shaft seal is retained in the pump head by a cover and screws. It can be replaced without removing the motor.

The chambers and impellers are made of stainless-steel sheet. The chambers are provided with a PTFE neck ring offering improved sealing and high efficiency. The impellers have smooth surfaces, and the shape of the blades ensure a high efficiency.

The base is made of cast iron. Both the inlet and the outlet side of the base have two pressure gauge tapings. The pump is secured to the foundation by four bolts through the base plate. The flanges are fastened to the base by means of locking rings.

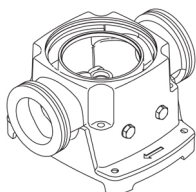

Motor

The motor is a totally enclosed, fan-cooled motor with principal dimensions to IEC and DIN standards. The motor is flange-mounted with free-hole flange (FF).

Motor-mounting designation in accordance with IEC 60034-7: IM B 5 (Code I) / IM 3001 (Code II).

Electrical tolerances comply with IEC 60034.

The motor does not incorporate motor protection and must be connected to a motor-protective circuit breaker which can be manually reset. The motor-protective circuit breaker must be set according to the rated current of the motor (I1/1).

The motor has built-in thermal protection (PTO current and temperature sensors) in accordance with IEC 60034-11 and requires no further motor protection. The protection reacts to both slow- and quick-rising temperatures, e.g. constant overload and stalled conditions.

As the thermal protection incorporates automatic reset, the motor must be connected in a way which ensures that the automatic reset cannot cause accidents.

Technical data

Liquid:
Pumped liquid: Water
Liquid temperature range: -30 .. 120 °C



Company name:

Created by:

Phone:

Date:

16/02/2026

Qty.	Description
1	<p>Selected liquid temperature: 20 °C Density: 998.2 kg/m³</p> <p>Technical: Pump speed on which pump data are based: 3508 rpm Rated flow: 159 US GPM Rated head: 53.81 psi Actual impeller diameter: 118.4 mm Pump orientation: Vertical Shaft seal arrangement: Single Primary shaft seal: HQQE Code for shaft seal: HQQE Approvals: CURUS Approvals for drinking water: NSF/ANSI 61 Curve tolerance: ISO9906:2012 3B</p> <p>Materials: Type key, code for materials: A Type key, code for rubber components. E = EPDM, V=FKM: E Base: Cast iron EN 1563 EN-GJS-500-7 ASTM A536 80-55-06 Impeller: Stainless steel EN 1.4301 AISI 304 Bearing: SIC Support bearing: Graflon</p> <p>Installation: Maximum ambient temperature: 40 °C Maximum operating pressure: 16 bar Max pressure at stated temp: 16 bar / 120 °C 16 bar / -30 °C Type of connection: ANSI Size of inlet connection: 2 1/2 inch Size of outlet connection: 2 1/2 inch Pressure rating for connection: PN 16 Flange rating inlet: 150 lb Flange size for motor: 213TC</p> <p>Electrical data: Motor standard: NEMA Motor type: WEG Rated power - P2: 5.5 kW Power (P2) required by pump: 5.5 kW Mains frequency: 60 Hz Rated voltage: 1 x 208-230 V Service factor: 1.15</p>



Company name:

Created by:

Phone:

Date:

16/02/2026

Qty.	Description
1	Rated current: 31.7-28.8 A
	Starting current: 710 %
	Cos phi - power factor: 0.99
	Rated speed: 3515 rpm
	IE efficiency: 84.0%
	Motor efficiency at full load: 84.0 %
	Motor efficiency at 3/4 load: 82.5 %
	Motor efficiency at 1/2 load: 78.5 %
	Number of poles: 2
	Enclosure class (IEC 34-5): IP55
	Insulation class (IEC 85): F
	Motor No: 99883305
	Controls:
	Frequency converter: None
	Others:
	DOE Pump Energy Index CL: 0.87
	Net weight: 122 kg
	Gross weight: 130 kg
	Shipping volume: 0.309 m ³



Company name:

Created by:

Phone:

Date:

16/02/2026

99917930 CR 32-2-1 A-G-A-E-HQQE 60 Hz

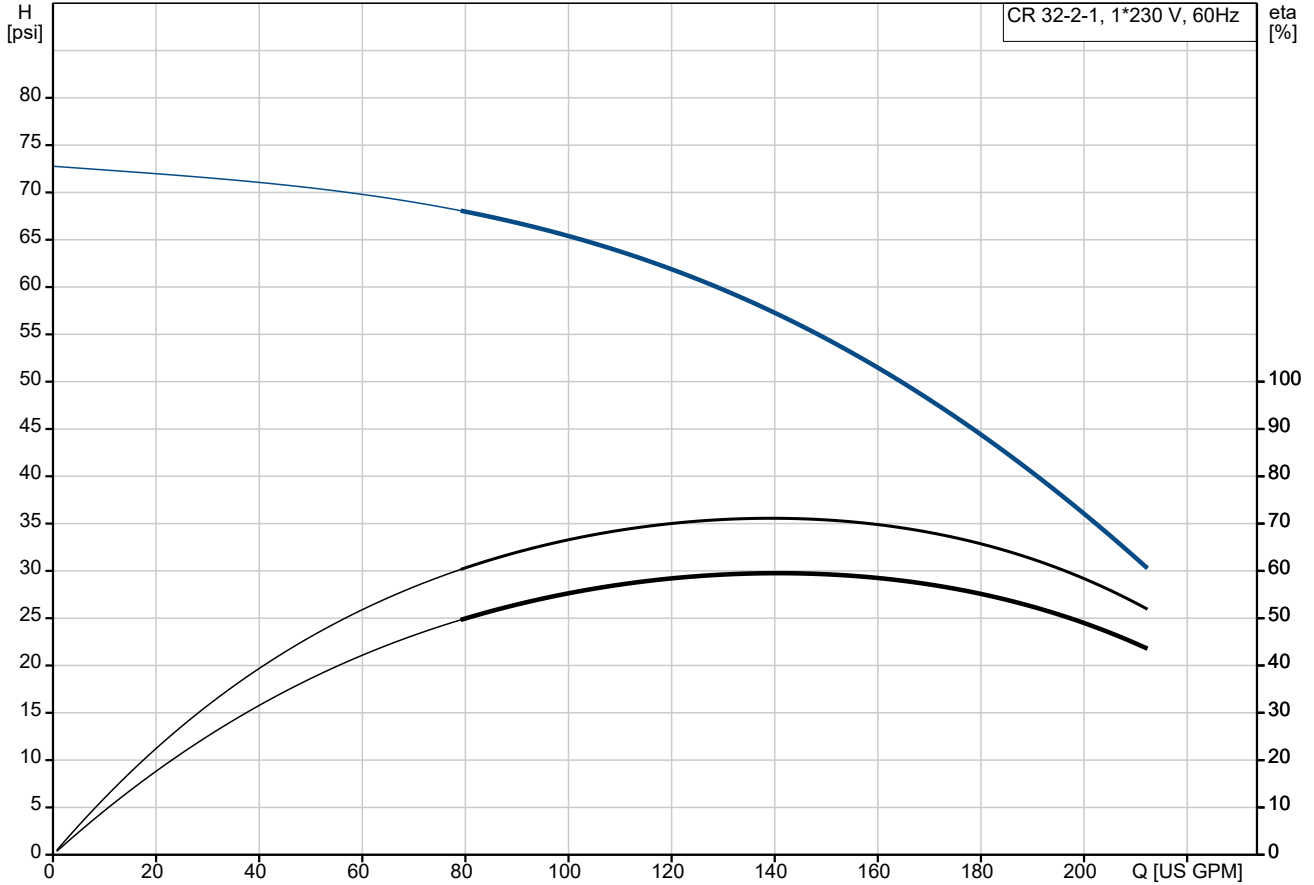

Pumped liquid = Water
Liquid temperature during operation = 20 °C
Density = 998.2 kg/m³

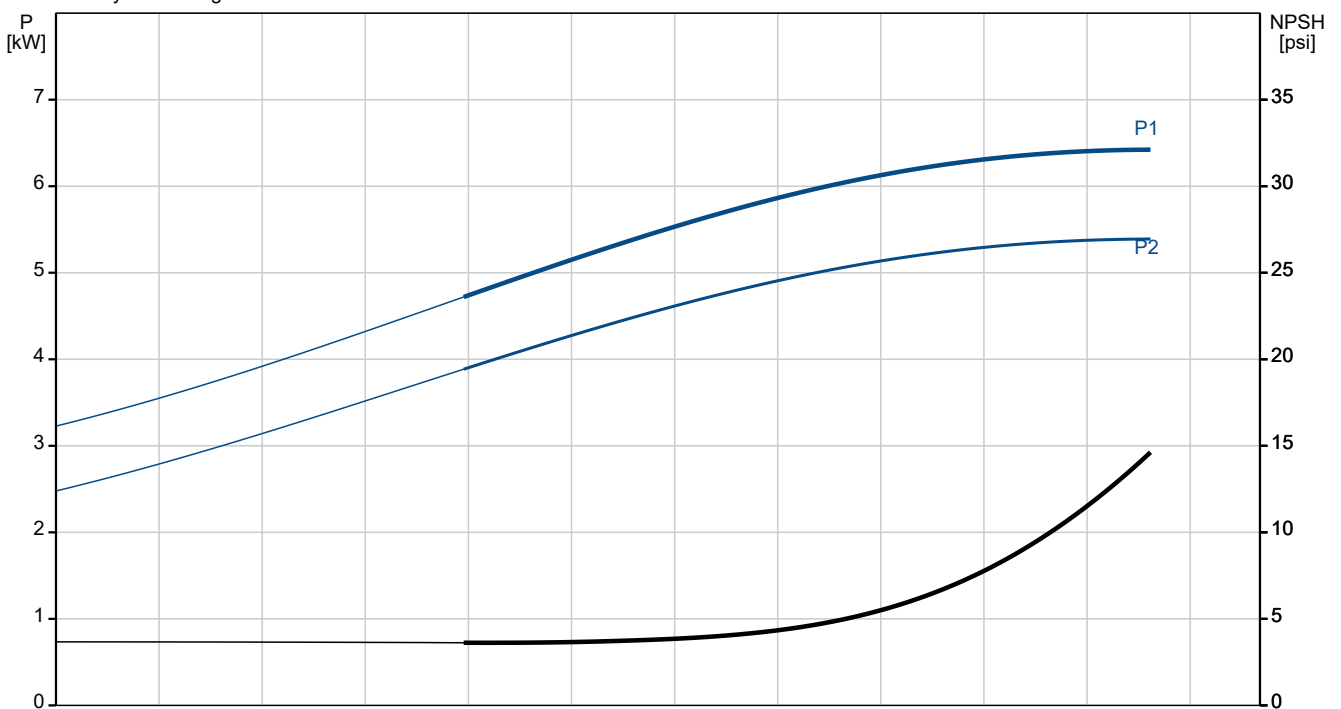

Description	Value
General information:	
Product name:	CR 32-2-1 A-G-A-E-HQQE
Product No:	99917930
EAN number:	5715114127691
Technical:	
Pump speed on which pump data are based:	3508 rpm
Rated flow:	159 US GPM
Rated head:	53.81 psi
Maximum head:	72.98 psi
Actual impeller diameter:	118.4 mm
Stages:	2
Impellers:	2
Number of reduced-diameter impellers:	1
Low NPSH:	N
Pump orientation:	Vertical
Shaft seal arrangement:	Single
Primary shaft seal:	HQQE
Code for shaft seal:	HQQE
Approvals:	CURUS
Approvals for drinking water:	NSF/ANSI 61
Curve tolerance:	ISO9906:2012 3B
Pump No:	96416357
Pump version:	A
Model:	B
Cooling:	IC 411
Materials:	
Type key, code for materials:	A
Type key, code for rubber components. E = EPDM, V=FKM:	E
Base:	Cast iron EN 1563 EN-GJS-500-7
Impeller:	ASTM A536 80-55-06 Stainless steel EN 1.4301 AISI 304
Material code:	A
Code for rubber:	E
Bearing:	SIC
Support bearing:	Graflon
Installation:	
Maximum ambient temperature:	40 °C
Maximum operating pressure:	16 bar
Max pressure at stated temp:	16 bar / 120 °C 16 bar / -30 °C
Type key, code for pipework connection:	G
Type of connection:	ANSI
Size of inlet connection:	2 1/2 inch
Size of outlet connection:	2 1/2 inch
Pressure rating for connection:	PN 16
Flange rating inlet:	150 lb
Flange size for motor:	213TC
Connect code:	G
Liquid:	
Pumped liquid:	Water
Liquid temperature range:	-30 .. 120 °C

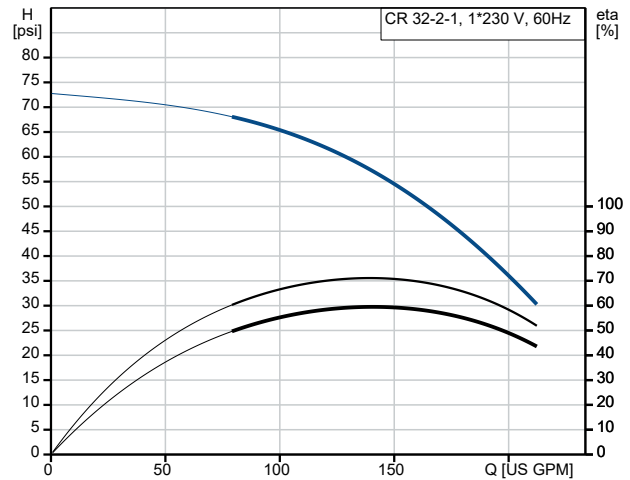

Pumped liquid = Water
Liquid temperature during operation = 20 °C
Density = 998.2 kg/m³

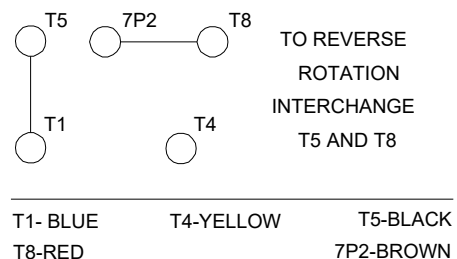
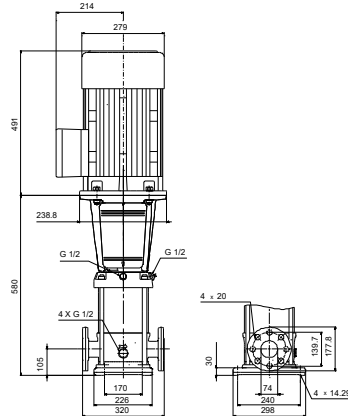
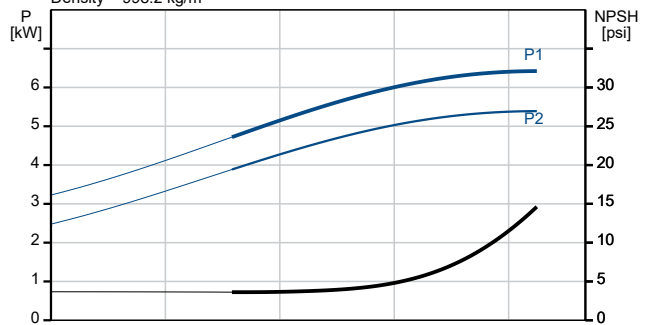



Company name:

Created by:

Phone:

Date:

16/02/2026

Description	Value
Selected liquid temperature:	20 °C
Density:	998.2 kg/m ³
Electrical data:	
Motor standard:	NEMA
Motor type:	WEG
Rated power - P2:	5.5 kW
Power (P2) required by pump:	5.5 kW
KVA code:	F
Mains frequency:	60 Hz
Rated voltage:	1 x 208-230 V
Service factor:	1.15
Rated current:	31.7-28.8 A
Starting current:	710 %
SF current:	31.7/44.6 A
Cos phi - power factor:	0.99
Rated speed:	3515 rpm
IE efficiency:	84.0%
Motor efficiency at full load:	84.0 %
Motor efficiency at 3/4 load:	82.5 %
Motor efficiency at 1/2 load:	78.5 %
Number of poles:	2
Enclosure class (IEC 34-5):	IP55
Insulation class (IEC 85):	F
Built-in motor protection:	NONE
Motor No:	99883305
Controls:	
Frequency converter:	None
Others:	
DOE Pump Energy Index CL:	0.87
Net weight:	122 kg
Gross weight:	130 kg
Shipping volume:	0.309 m ³

99917930 CR 32-2-1 A-G-A-E-HQQE 60 Hz

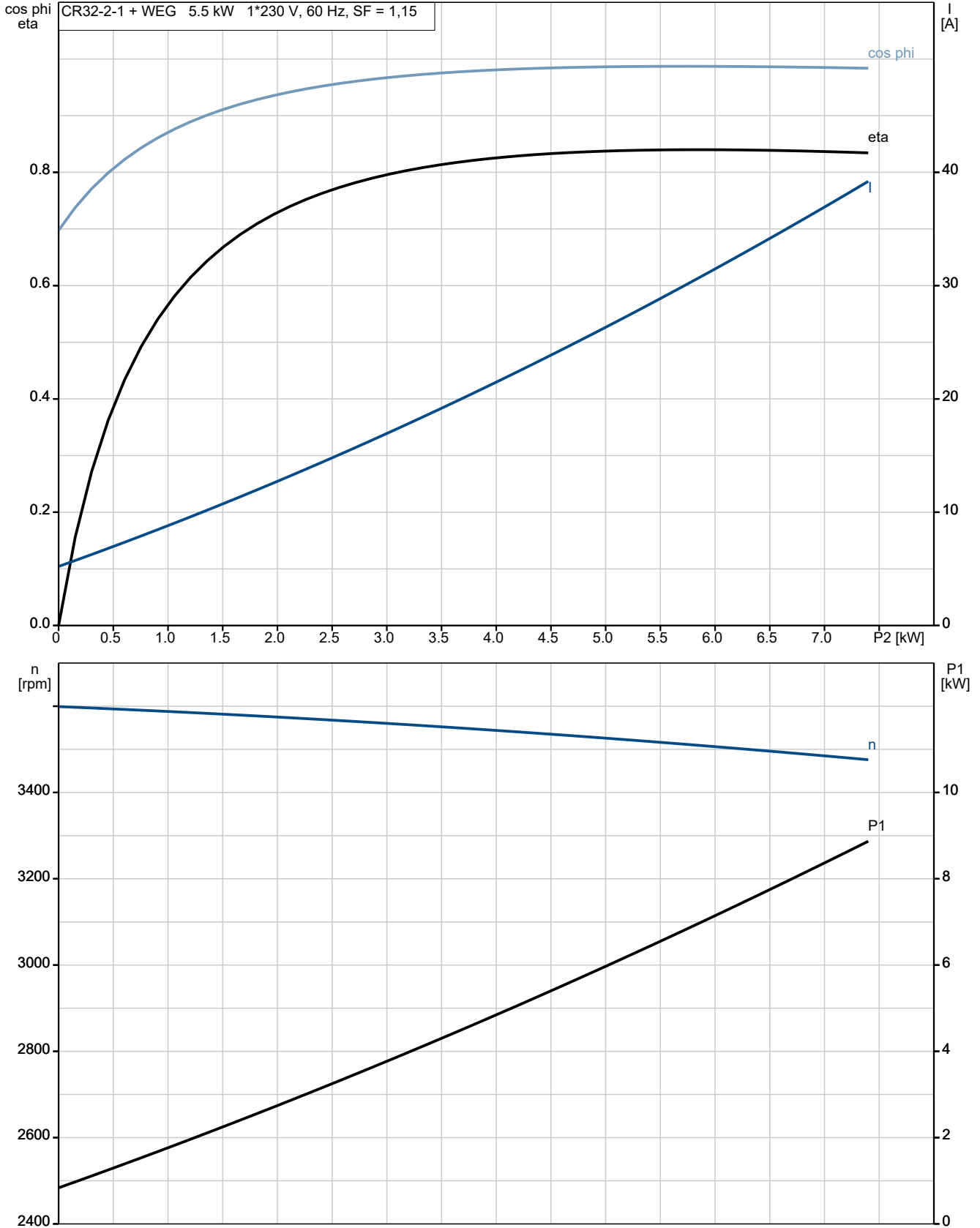

99917930 CR 32-2-1 A-G-A-E-HQQE 60 Hz

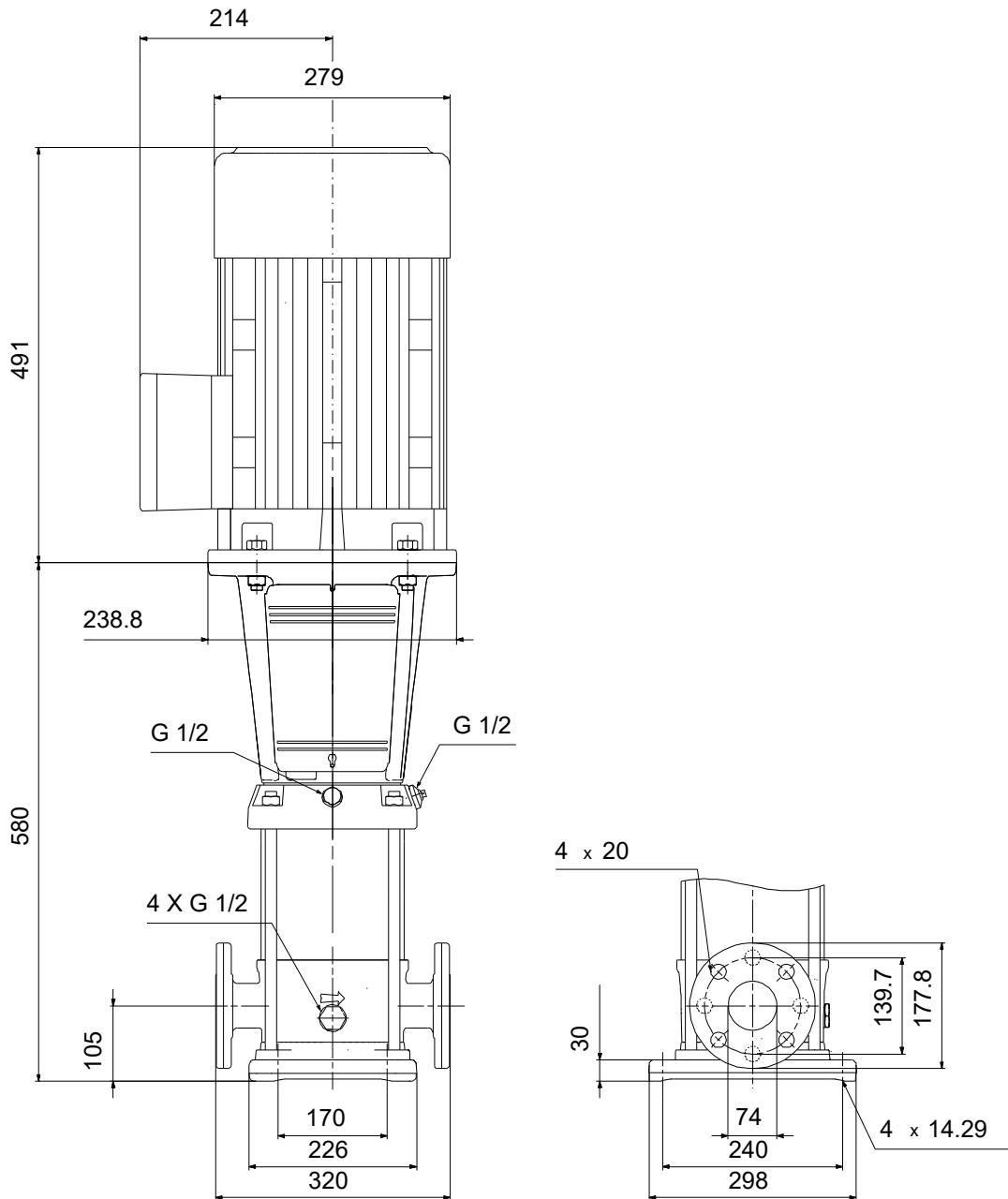

Note! All units are in [mm] unless others are stated.
Disclaimer: This simplified dimensional drawing does not show all details.

99917930 CR 32-2-1 A-G-A-E-HQQE 60 Hz

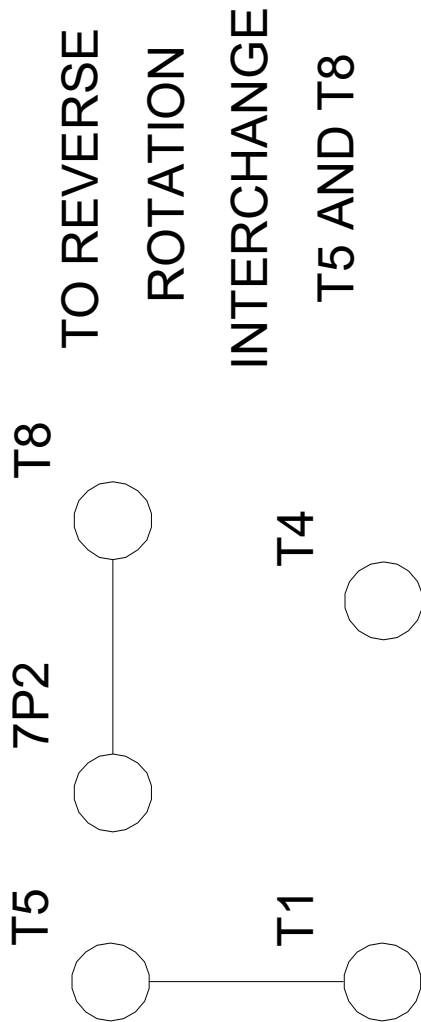

- | | | |
|----------|------------|------------|
| T1- BLUE | T4- YELLOW | T5- BLACK |
| T8- RED | | 7P2- BROWN |

Note! All units are in [mm] unless others are stated.