

ABB MACHINERY DRIVES

ACS180 drives

Hardware manual



ACS180 drives

Hardware manual

Table of contents



1. Safety instructions



4. Mechanical installation



6. Electrical installation



3AXD50000467945 Rev B
EN

Original instructions
EFFECTIVE: 2022-06-28

Table of contents

1 Safety instructions

Contents of this chapter	13
Use of warnings and notes	13
General safety in installation, start-up and maintenance	14
Electrical safety in installation, start-up and maintenance	16
Electrical safety precautions	16
Additional instructions and notes	17
Printed circuit boards	17
Grounding	18
General safety in operation	19
Additional instructions for permanent magnet motor drives	19
Safety in installation, start-up, maintenance	19
Safety in operation	20

2 Introduction to the manual

Contents of this chapter	21
Applicability	21
Target audience	21
Purpose of the manual	21
Categorization by frame size	21
Quick installation and commissioning flowchart	21
Terms and abbreviations	23
Related manuals	24
Manuals on internet	24

3 Operation principle and hardware description

Contents of this chapter	25
Operation principle	26
Simplified main circuit diagram	26
Product variants	26
Layout	27
Frame sizes R0...R1	27
Frame sizes R2...R4	28
Control connections	29
Standard variant (ACS180-04S-...)	29
Base variant (ACS180-04N-...)	30
Control panel options	31



6 Table of contents

Drive labels	31
Model information label	31
Type designation label	32
Type designation key	32
Control panel	33
Home view	34
Status icon	34
Message view	35
Options view	35
Menu	35

4 Mechanical installation

Contents of this chapter	37
Installation alternatives	37
Examining the installation site	38
Required tools	38
Unpacking the delivery	38
Installing the drive	40
To install the drive with screws	40
To install the drive to a DIN installation rail for frame sizes R3 and R4 ..	42

5 Guidelines for planning the electrical installation

Contents of this chapter	43
Limitation of liability	43
Selecting the main supply disconnecting device	43
European Union and United Kingdom	44
North America	44
Other regions	44
Selecting the main contactor	44
Checking the compatibility of the motor and drive	44
Selecting the power cables	45
General guidelines	45
Typical power cable sizes	45
Power cable types	45
Preferred power cable types	45
Alternate power cable types	46
Not allowed power cable types	47
Additional guidelines, North America	47
Metal conduit	48
Power cable shield	48
Selecting the control cables	49
Shielding	49
Signals in separate cables	49
Signals that can be run in the same cable	50



Relay cable	50
Control panel to drive cable	50
PC tool cable	50
Routing the cables	50
General guidelines – IEC	50
General guidelines – North America	51
Continuous motor cable shield/conduit or enclosure for equipment on the motor cable	52
Separate control cable ducts	53
Implementing short-circuit and thermal overload protection	53
Protecting the drive and input power cable in short-circuits	53
Protecting the motor and motor cable in short-circuits	53
Protecting the drive, and the input power and motor cables against thermal overload	54
Protecting the motor against thermal overload	54
Protecting the motor against overload without thermal model or temperature sensors	54
Implementing motor temperature sensor connection	55
Protecting the drive against ground faults	55
Residual current device compatibility	55
Implementing the Emergency stop function	56
Implementing the Safe torque off function	56
Using a safety switch between the drive and the motor	56
Implementing the control of a contactor between drive and motor	56
Protecting the contacts of relay outputs	57

6 Electrical installation

Contents of this chapter	59
Warnings	59
Required tools	59
Measuring the insulation	60
Measuring the insulation resistance of the drive	60
Measuring the insulation resistance of the input power cable	60
Measuring the insulation resistance of the motor and motor cable	60
Earthing system compatibility check	61
EMC filter	61
When to disconnect the EMC filter	61
Disconnecting the EMC filter	62
Guidelines for installing the drive to a TT system	63
Identifying the grounding system of the electrical power network	63
Connecting the power cables	65
Connection diagram	65
Connection procedure	66
Connecting the control cables	68
Default I/O connection diagram (ABB standard macro)	69



8 Table of contents

Control cable connection procedure	70
Additional information on the control connections	72
Connecting EIA-485 fieldbus cable to the drive	72
PNP configuration for digital inputs	73
NPN configuration for digital inputs	73
Connection examples of two-wire and three-wire sensors	74
Safe torque off	74
Communication mode jumper J2	74
Connecting a PC	75

7 Installation checklist

Contents of this chapter	77
Checklist	77

8 Maintenance

Contents of this chapter	79
Maintenance intervals	79
Description of symbols	79
Recommended maintenance intervals after start-up	80
Cleaning the heatsink	80
Replacing the cooling fans	81
To replace the cooling fan for frame size R1	81
To replace the cooling fan for frame size R2	83
To replace the cooling fan for frame size R3	85
To replace the cooling fan for frame size R4	88
Capacitors	89
Reforming the capacitors	89

9 Technical data

Contents of this chapter	91
Ratings	91
IEC ratings	91
UL (NEC) ratings	92
Definitions	94
Sizing	94
Output derating	94
Surrounding air temperature derating	97
Altitude derating	99
Switching frequency derating	99
Fuses	101
gG fuses (IEC)	101
gR or aR -type fuses (IEC)	102
UL fuses (UL(NEC))	103



Alternate short-circuit protection	104
Miniature circuit breakers (IEC)	104
Manual self-protected combination motor controller – Type E USA (UL (NEC))	106
Dimensions and weights	108
Free space requirements	109
Losses, cooling data and noise	109
Terminal data for the power cables	110
Typical power cable sizes	113
Terminal data for the control cables	114
External EMC filters	114
Electrical power network specification	115
Motor connection data	116
Motor cable length	116
Operational functionality and motor cable length	116
EMC compatibility and motor cable length	118
Control connection data	119
Brake resistor connection data	120
Energy efficiency data (ecodesign)	120
Degrees of protection	120
Ambient conditions	120
Materials	122
Disposal	122
Applicable standards	122
Markings	123
Compliance with EN 61800-3	124
Definitions	124
Category C1	124
Category C2	125
Category C3	125
Category C4	125
UL checklist	127
Compliance with the European Machinery Directive	128
Disclaimers	128
Generic disclaimer	128
Cybersecurity disclaimer	128

10 Dimension drawings

Contents of this chapter	129
Frame R0	130
Frame R1	131
Frame R2	132
Frame R3	133
Frame R4	134



11 Resistor braking

Contents of this chapter 135

Safety 135

Operation principle 135

Selecting the brake resistor 135

 Reference brake resistors 137

 Definitions 137

Selecting and routing the brake resistor cables 138

 Minimizing electromagnetic interference 138

 Maximum cable length 138

Placing the brake resistors 138

Protecting the system in brake circuit fault situations 139

 Protecting the system in cable and brake resistor short-circuit situations 139

 Protecting the system against thermal overload 139

Mechanical and electrical installation of brake resistor 140

 Mechanical installation 140

 Electrical installation 141

 Measuring the insulation 141

 Connecting power cables 141

 Connection the control cables 141

Start-up 141



12 The Safe torque off function

Contents of this chapter 143

Description 143

 Compliance with the European Machinery Directive and the UK Supply of Machinery (Safety) Regulations 144

Wiring 145

 Connection principle 145

 Single ACS180 drive, internal power supply 145

 Single ACS180 drive, external power supply 146

 Wiring examples 147

 Single ACS180 drive, internal power supply 147

 Single ACS180 drive, external power supply 147

 Multiple ACS180 drives, internal power supply 148

 Multiple ACS180 drives, external power supply 149

 Activation switch 149

 Cable types and lengths 150

 Grounding of protective shields 150

Operation principle 151

Start-up including validation test 152

 Competence 152

 Validation test reports 152

Validation test procedure	152
Use	154
Maintenance	156
Competence	156
Fault tracing	157
Safety data	158
Terms and abbreviations	160
TÜV certificate	161
Declarations of conformity	162

Further information



1

Safety instructions

Contents of this chapter

This chapter contains the safety instructions which you must obey when you install, start-up, operate and do maintenance work on the drive. If you ignore the safety instructions, injury, death or damage can occur.



Use of warnings and notes

Warnings tell you about conditions which can cause injury or death, or damage to the equipment. They also tell you how to prevent the danger. Notes draw attention to a particular condition or fact, or give information on a subject.

The manual uses these warning symbols:

**WARNING!**

Electricity warning tells about hazards from electricity which can cause injury or death, or damage to the equipment.

**WARNING!**

General warning tells about conditions other than those caused by electricity, which can cause injury or death, or damage to the equipment.

**WARNING!**

Electrostatic sensitive devices warning tells you about the risk of electrostatic discharge which can cause damage to the equipment.

General safety in installation, start-up and maintenance

These instructions are for all personnel who do work on the drive.



WARNING!

Obey these instructions. If you ignore them, injury or death, or damage to the equipment can occur.

- Keep the drive in its package until you install it. After unpacking, protect the drive from dust, debris and moisture.
 - Use the required personal protective equipment: safety shoes with metal toe cap, safety glasses, protective gloves and long sleeves, etc. Some parts have sharp edges.
 - Beware of hot surfaces. Some parts, such as heatsinks of power semiconductors, and brake resistors, remain hot for a while after disconnection of the electrical supply.
 - Vacuum clean the area around the drive before the start-up to prevent the drive cooling fan from drawing dust inside the drive.
 - Make sure that debris from drilling, cutting and grinding does not go into the drive during installation. Electrically conductive debris inside the drive can cause damage or malfunction.
 - Make sure that there is sufficient cooling. See the technical data.
 - Before you connect voltage to the drive, make sure that all covers are in place. Do not remove the covers when voltage is connected.
 - Before you adjust the drive operation limits, make sure that the motor and all driven equipment can operate throughout the set operation limits.
 - Before you activate the automatic fault reset or automatic restart functions of the drive control program, make sure that no dangerous situations can occur. These functions reset the drive automatically and continue operation after a fault or supply break. If these functions are activated, the installation must be clearly marked as defined in IEC/EN/UL 61800-5-1, subclause 6.5.3, for example, "THIS MACHINE STARTS AUTOMATICALLY".
 - The maximum number of drive power-ups is five in ten minutes. Too frequent power-ups can damage the charging circuit of the DC capacitors.
 - If you have connected safety circuits to the drive (for example, Safe torque off or emergency stop), validate them at start-up. See separate instructions for the safety circuits.
 - Beware of hot air exiting from the air outlets.
 - Do not cover the air inlet or outlet when the drive is running.
-



Note:

- If you select an external source for the start command and it is on, the drive will start immediately after fault reset unless you configure the drive for pulse start. See the firmware manual.
- If the drive is in remote control mode, you cannot stop or start the drive with the control panel.
- Only authorized persons are allowed to repair a malfunctioning drive.



Electrical safety in installation, start-up and maintenance

■ Electrical safety precautions

These electrical safety precautions are for all personnel who do work on the drive, motor cable or motor.



WARNING!

Obey these instructions. If you ignore them, injury or death, or damage to the equipment can occur.

If you are not a qualified electrical professional, do not do installation or maintenance work.

Do these steps before you begin any installation or maintenance work.

1. Clearly identify the work location and equipment.
 2. Disconnect all possible voltage sources. Make sure that re-connection is not possible. Lock out and tag out.
 - Open the main disconnecting device of the drive.
 - If you have a permanent magnet motor connected to the drive, disconnect the motor from the drive with a safety switch or by other means.
 - Disconnect all dangerous external voltages from the control circuits.
 - After you disconnect power from the drive, always wait 5 minutes to let the intermediate circuit capacitors discharge before you continue.
 3. Protect any other energized parts in the work location against contact.
 4. Take special precautions when close to bare conductors.
 5. Measure that the installation is de-energized. Use a quality voltage tester.
 - Before and after measuring the installation, verify the operation of the voltage tester on a known voltage source.
 - Make sure that the voltage between the drive input power terminals (L1, L2, L3) and the grounding (PE) busbar is zero.
 - Make sure that the voltage between the drive output terminals (T1/U, T2/V, T3/W) and the grounding (PE) busbar is zero.
 - Make sure that the voltage between the drive DC terminals (UDC+ and UDC-) and the grounding (PE) terminal is zero.

Note: If cables are not connected to the drive DC terminals, measuring the voltage from the DC terminal screws can give incorrect results.
 6. Install temporary grounding as required by the local regulations.
 7. Ask for a permit to work from the person in control of the electrical installation work.
-



■ Additional instructions and notes



WARNING!

Obey these instructions. If you ignore them, injury or death, or damage to the equipment can occur.

If you are not a qualified electrical professional, do not do installation or maintenance work.

- Make sure that the electrical power network, motor/generator, and environmental conditions agree with the drive data.
- Do not do insulation or voltage withstand tests on the drive.
- If you have a cardiac pacemaker or other electronic medical device, keep away from the area near motor, drive, and the drive power cabling when the drive is in operation. There are electromagnetic fields present which can interfere with the function of such devices. This can cause a health hazard.

Note:

- When the drive is connected to the input power, the motor cable terminals and the DC bus are at a dangerous voltage.
After disconnecting the drive from the input power, these remain at a dangerous voltage until the intermediate circuit capacitors have discharged.
- External wiring can supply dangerous voltages to the relay outputs of the control units of the drive.
- The Safe torque off function does not remove the voltage from the main and auxiliary circuits. The function is not effective against deliberate sabotage or misuse.

Printed circuit boards



WARNING!

Use a grounding wristband when you handle printed circuit boards. Do not touch the boards unnecessarily. The boards contain components sensitive to electrostatic discharge.



■ Grounding

These instructions are for all personnel who are responsible for the grounding of the drive.



WARNING!

Obey these instructions. If you ignore them, injury or death, or equipment malfunction can occur, and electromagnetic interference can increase.

If you are not a qualified electrical professional, do not do grounding work.

- Always ground the drive, the motor and adjoining equipment. This is necessary for the personnel safety.
- Make sure that the conductivity of the protective earth (PE) conductors is sufficient and that other requirements are met. See the electrical planning instructions of the drive. Obey the applicable national and local regulations.
- When using shielded cables, make a 360° grounding of the cable shields at the cable entries to reduce electromagnetic emission and interference.
- In a multiple-drive installation, connect each drive separately to the protective earth (PE) busbar of the power supply.



General safety in operation

These instructions are for all personnel that operate the drive.



WARNING!

Obey these instructions. If you ignore them, injury or death, or damage to the equipment can occur.

- If you have a cardiac pacemaker or other electronic medical device, keep away from the area near motor, drive, and the drive power cabling when the drive is in operation. There are electromagnetic fields present which can interfere with the function of such devices. This can cause a health hazard.
- Give a stop command to the drive before you reset a fault. If you have an external source for the start command and the start is on, the drive will start immediately after the fault reset, unless you configure the drive for pulse start. See the firmware manual.
- Before you activate the automatic fault reset or automatic restart functions of the drive control program, make sure that no dangerous situations can occur. These functions reset the drive automatically and continue operation after a fault or supply break. If these functions are activated, the installation must be clearly marked as defined in IEC/EN/UL 61800-5-1, subclause 6.5.3, for example, "THIS MACHINE STARTS AUTOMATICALLY".

Note:

- The maximum number of drive power-ups is five in ten minutes. Too frequent power-ups can damage the charging circuit of the DC capacitors. If you need to start or stop the drive, use the control panel keys or commands through the I/O terminals of the drive.
- If the drive is in remote control mode, you cannot stop or start the drive with the control panel.

Additional instructions for permanent magnet motor drives

■ Safety in installation, start-up, maintenance

These are additional warnings concerning permanent magnet motor drives. The other safety instructions in this chapter are also valid.



WARNING!

Obey these instructions. If you ignore them, injury or death, or damage to the equipment can occur.

If you are not a qualified electrical professional, do not do installation or maintenance work.

20 Safety instructions

- Do not do work on the drive when a rotating permanent magnet motor is connected to it. A rotating permanent magnet motor energizes the drive including its input and output power terminals.

Before installation, start-up and maintenance work on the drive:

- Stop the drive.
- Disconnect the motor from the drive with a safety switch or by other means.
- If you cannot disconnect the motor, make sure that the motor cannot rotate during work. Make sure that no other system, like hydraulic crawling drives, can rotate the motor directly or through any mechanical connection like belt, nip, rope, etc.
- Do the steps in section [Electrical safety precautions](#) (page 16).
- Install temporary grounding to the drive output terminals (T1/U, T2/V, T3/W). Connect the output terminals together as well as to the PE.

During the start-up:

- Make sure that the motor cannot run overspeed, for example, driven by the load. Motor overspeed causes overvoltage that can damage or destroy the capacitors in the intermediate circuit of the drive.



■ Safety in operation



WARNING!

Make sure that the motor cannot run overspeed, for example, driven by the load. Motor overspeed causes overvoltage that can damage or destroy the capacitors in the intermediate circuit of the drive.

2

Introduction to the manual

Contents of this chapter

The chapter describes the manual: the applicability, target audience and purpose of the manual. The chapter contains a list of related manuals and a flowchart for installation and commissioning.

Applicability

This manual is applicable to ACS180 drives.

Target audience

The reader is expected to know the fundamentals of electricity, wiring, electrical components and electrical schematic symbols.

The manual is written for readers worldwide. Both SI and imperial units are shown.

Purpose of the manual

This manual gives information needed to plan the installation, install, commission and service the drive.

Categorization by frame size

The drives are manufactured in frame sizes R0, R1, R2, R3 and R4. The instructions and information that is applicable only to certain frames indicate the frame size. The frame size is shown on the type designation label.

Quick installation and commissioning flowchart

22 Introduction to the manual

Task	See
Identify the frame size: R0, R1, R2, R3 or R4.	Type designation key (page 32)
↓	
Plan the installation. Check the ambient conditions, ratings and required cooling air flow.	Guidelines for planning the electrical installation (page 43) Technical data (page 91)
↓	
Unpack and check the drive.	Unpacking the delivery (page 38)
↓	
If the drive will be connected to an IT (ungrounded) system, make sure that the internal EMC filter is not connected.	Earthing system compatibility check (page 61)
↓	
Install the drive mechanically.	Installing the drive (page 40)
↓	
Route the cables.	Routing the cables (page 50)
↓	
Connect the power cables.	Connecting the power cables (page 65)
↓	
Connect the control cables.	Connecting the control cables (page 68)
↓	
Examine the installation.	Installation checklist (page 77)
↓	
Commission the drive.	Refer to the <i>ACS180 Quick installation and start-up guide</i> (3AXD50000510344 [English]) and the <i>ACS180 Firmware manual</i> (3AXD50000467860 [English]).

Terms and abbreviations

Term	Description
ACS-AP-...	Assistant control panel
BCBL-01	Optional USB to RJ45 cable
Capacitor bank	The capacitors connected to the DC link
Control unit	The part in which the control program runs.
DC link	DC circuit between rectifier and inverter
DC link capacitors	Energy storage which stabilizes the intermediate circuit DC voltage
Drive	Frequency converter for controlling AC motors
EFB	Embedded fieldbus
EMC	Electromagnetic compatibility
Frame, frame size	Physical size of the drive or power module
IGBT	Insulated gate bipolar transistor
Intermediate circuit	DC circuit between rectifier and inverter
Inverter	Converts direct current and voltage to alternating current and voltage.
Macro	A pre-defined set of default values of parameters in a drive control program.
Parameter	In the drive control program, user-adjustable operation instruction to the drive, or signal measured or calculated by the drive. In some (for example fieldbus) contexts, a value that can be accessed as an object. For example, variable, constant, or signal.
PLC	Programmable logic controller
Rectifier	Converts alternating current and voltage to direct current and voltage
RFI	Radio-frequency interference
SIL	Safety integrity level (1...3) (IEC 61508, IEC 62061, IEC 61800-5-2)
STO	Safe torque off (IEC/EN 61800-5-2)

Related manuals

Name	Code
Drive manuals and guides	
ACS180 drives hardware manual	3AXD50000467945
ACS180 quick installation and start-up guide	3AXD50000510344
ACS180 firmware manual	3AXD50000467860
ACS180 recycling instructions	3AXD50000613342
Option manuals and guides	
ACS-AP-I, -S, -W and ACH-AP-H, -W Assistant control panel user's manual	3AUA0000085685
Tool and maintenance manuals	
Drive Composer Start-up and maintenance PC tool user's manual	3AUA0000094606
Converter module capacitor reforming instructions	3BFE64059629

Manuals on internet

You can find manuals and other product documents in PDF format on the Internet at www.abb.com/drives/documents.

The code and link below open an online listing of the manuals applicable to this product.



[ACS180 manuals](#)



3

Operation principle and hardware description

Contents of this chapter

This chapter describes the operation principle, layout, type designation label and type designation information. It shows a general diagram of the power connections and control interfaces.

Operation principle

The ACS180 is a drive for controlling asynchronous AC induction motors and permanent magnet synchronous motors. It is optimized for cabinet mounting.

■ Simplified main circuit diagram

The figure shows the simplified main circuit diagram of the drive.

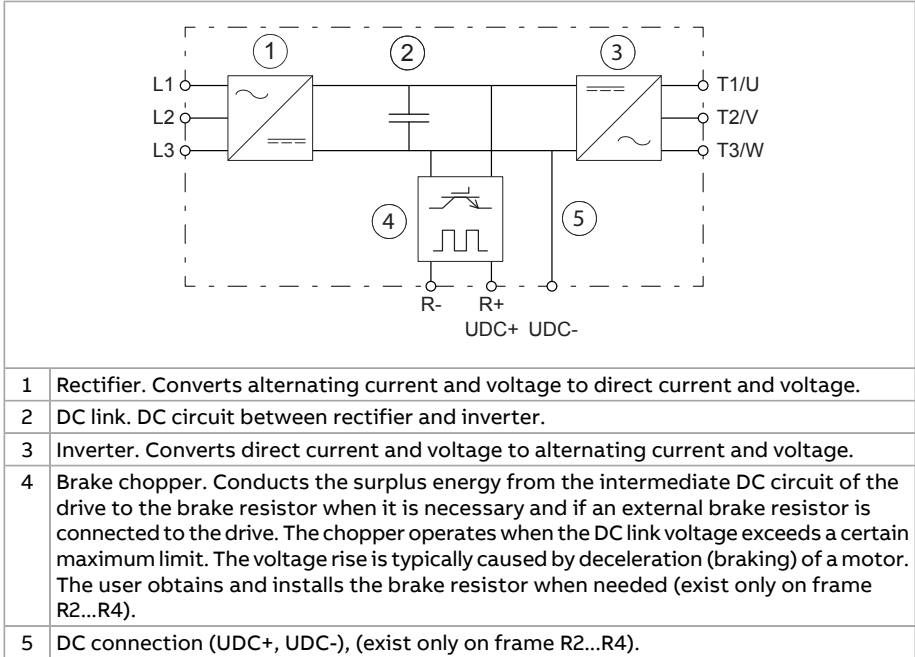

Product variants

The product has two primary variants:

- Standard variant (ACS180-04S-...) which has integrated Safe torque off (STO) and category C2, C3 or C4 EMC level (C2 for ...-1 type, C3 for ...-4 type, C4 for ...-2 type).
- Base variant (ACS180-04N-...) which has category C4 EMC level (no internal EMC filter) and no integrated STO.

Layout

■ Frame sizes R0...R1

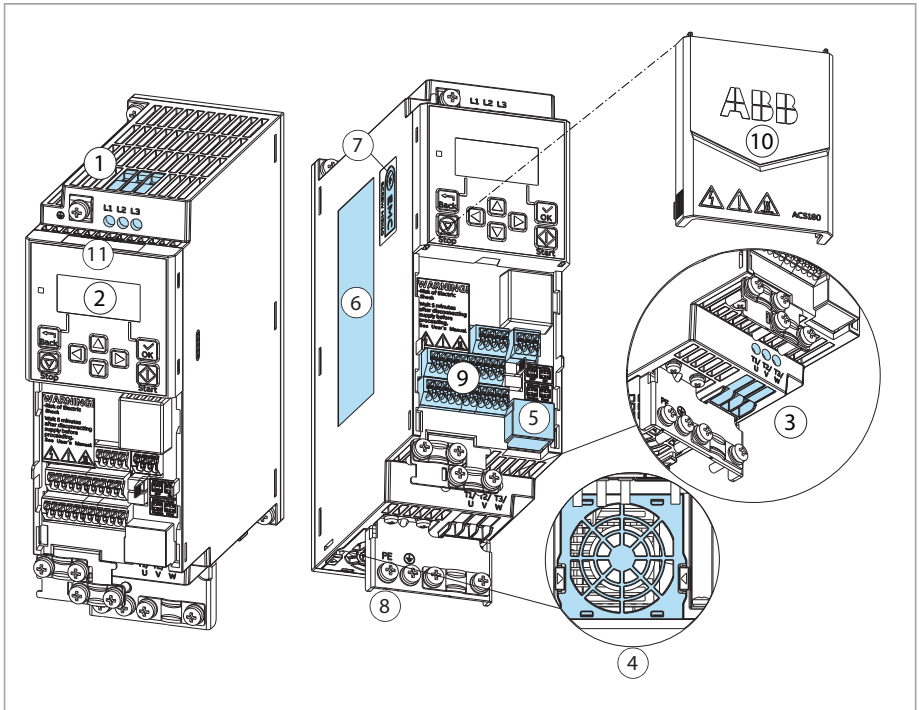

1	Input power connection terminal	7	EMC filter grounding screw ¹⁾
2	Control panel, display and status LED	8	PE connection (motor)
3	Motor connection terminal	9	Fixed control terminals
4	Cooling fan	10	Front cover
5	Panel and PC tool port (RJ45)	11	Model information label
6	Type designation label		

¹⁾ Drive types ACS180-04N-xxxx-x do not have this EMC screw.

■ Frame sizes R2...R4

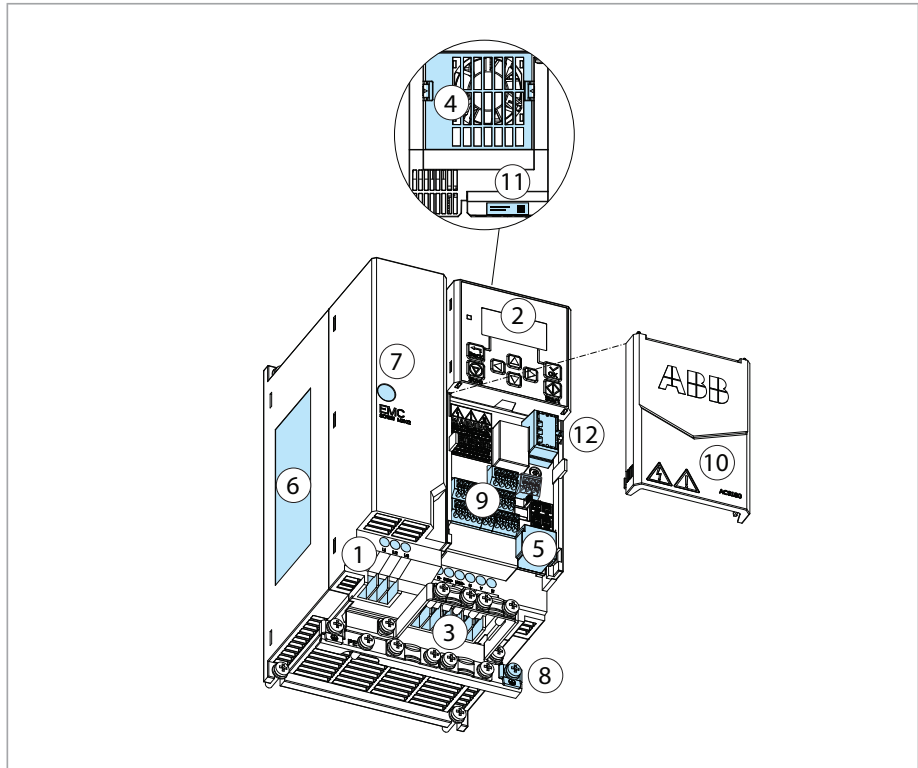

1	Input power connection terminal	7	EMC filter grounding screw ¹⁾
2	Control panel, display and status LED	8	PE connection (motor)
3	Motor connection terminal	9	Fixed control terminals
4	Cooling fan	10	Front cover
5	Panel and PC tool port (RJ45)	11	Model information label
6	Type designation label	12	Cold configuration connection for CCA-01

¹⁾ Drive types ACS180-04N-xxxx-x do not have this EMC screw.

Control connections

■ Standard variant (ACS180-04S-...)

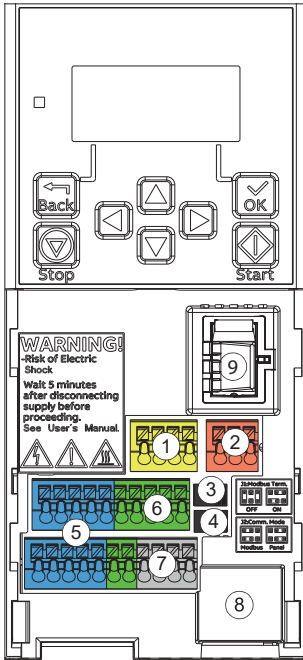

Connections:

1. Safe torque-off connections
2. Relay output connection
3. Modbus termination jumper
4. Communication mode jumper
5. Digital inputs and outputs
6. Analog inputs and outputs
7. EIA-485 Modbus RTU
8. Panel connector (external panel or adapter for PC connection)
9. Cold configuration connection for CCA-01 (Frame sizes R2...R4 only).

30 Operation principle and hardware description

■ Base variant (ACS180-04N-...)

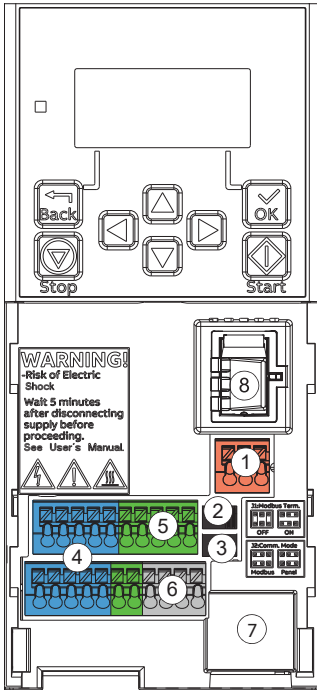

Connections:

1. Relay output connection
2. Modbus termination jumper
3. Communication mode jumper
4. Digital inputs and outputs
5. Analog inputs and outputs
6. EIA-485 Modbus RTU
7. Panel connector (external panel or adapter for PC connection)
8. Cold configuration connection for CCA-01 (Frame sizes R2...R4 only).

Control panel options

The drive supports these control panels:

- integrated control panel
- ACS-AP-I assistant control panel
- ACS-AP-S assistant control panel
- ACS-AP-W assistant control panel with Bluetooth
- ACS-BP-S basic control panel

For information on the assistant control panels, refer to the *ACS-AP-I, -S, -W and ACH-AP-H, -W Assistant control panels user's manual* (3AUA0000085685 [EN]).

In addition, you can order a control panel platform for cabinet door installation. These panel platforms are available:

Type	Description
DPMP-01	Control panel mounting platform (flush mounting) and cable
DPMP-02	Control panel mounting platform (surface mounting) and cable

Drive labels

The drive has two labels:

- Model information label at the top of the drive
- Type designation label on the left side of the drive.

Example labels are shown in this section.

■ Model information label

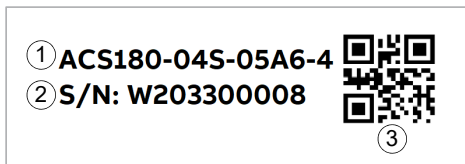

Code	Description
1	Drive type
2	Serial number
3	QR code for series number

■ Type designation label

ABB ① **ACS180-04S-04A0-4**

ABB Beijing Drive Systems Co., Ltd
No.1, Block D, A-10 Jixianqiao Beilu Chaoyang District Beijing China

Input U1 3~380...480 V AC
f1 50/60 Hz
U1(UL) 3ph 380Y/220...480Y/277 V AC

Output U2 3~0...U1
In 4.0/3.5 A
Ild 3.8/3.5 A
Ihd 3.3/3.0 A
f2 0...599 Hz
Pn/Pld 1.5 kW/2.0 hp
Phd 1.1 kW/1.5 hp

Input current is scaled by motor output current

Output	Input	Input (With 5% choke)
400/480 V	400/480 V	400/480 V
In 4.0/3.5	6.3/4.6	3.3/2.8
Ild 3.8/3.5	6.0/4.6	3.1/2.8
Ihd 3.3/3.0	4.3/3.4	2.5/2.1

② **R1**

④ Air cooling IP20 Icc 100 kA
UL open type IE2 (90;100) 1.6%
Origin China Made in China

⑤

⑥ W2043A0228

R-R-Abb-ACS180-4-R1

Code	Description
1	Drive type
2	Frame size
3	Nominal ratings
4	Degree of protection
5	Valid markings
6	S/N: Serial number of format MYYWWRXXXX, where M: Manufacturer designation YY: Year of manufacture: 20, 21, 22, ... for 2020, 2021, 2022, ... WW: Week of manufacture: 01, 02, 03, ... for week 1, week 2, week 3, ... R: Hardware revision that starts from A. XXXX: Running item number that starts each week from 0001.

Type designation key

The type designation shows the specifications and configuration of the drive. The table below presents the type code digits.

Sample type code 1: ACS180-04N-02A6-4

Sample type code 2: ACS180-04S-02A6-4

Code	Description
ACS180	Product series
04	Construction. 04=Module, IP20
N/S	EMC&STO. N=Basic variant (without STO; C4 EMC level); S=Standard variant (integrated STO; C2(1~230V), C3(3~400V) or C4(3~230V) EMC level).
02A6	Size. See the ratings table in the technical data.
4	Voltage rating. 1=1-phase 230 V AC, 2=3-phase 230V AC, 4=3-phase 380...480 V AC.

Control panel

The drive has an integrated control panel with a display and control keys.

For quick reference, there is an *ACS180 User interface guide* (3AXD50000606696 [multi lingual]).

Refer to the *ACS180 Firmware manual* (3AXD50000467860 [English]) for information on how to use the interface, start-up the drive and modify settings and parameters.

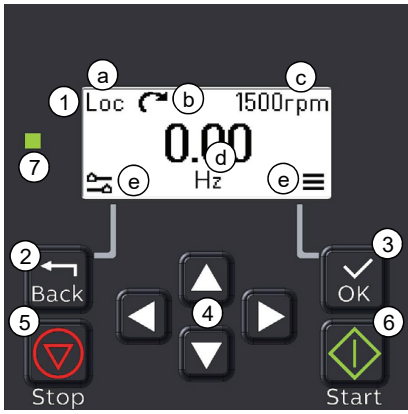

The diagram shows a control panel with a central display and several buttons. The display shows 'Loc' with a circular arrow icon (a), status icons (b), '1500rpm' (c), '0.00' (d), and 'Hz' (e). Below the display are buttons for 'Back' (2), 'Stop' (5), 'OK' (3), and 'Start' (6). There are also four arrow keys (4) for navigation. A status LED (7) is located to the left of the display.

1	Display (<i>Home view</i>): a) Control location: local or remote b) Status icons c) Reference target value d) Actual measured value e) Left and right softkey actions.
2	<i>Back</i> key (opens the <i>Options</i> view in the <i>Home</i> view)
3	<i>OK</i> key (opens the <i>Menu</i> in the <i>Home</i> view)
4	Arrow keys (menu navigation and setting values)
5	<i>Stop</i> key (when the drive is locally controlled)
6	<i>Start</i> key (when the drive is locally controlled)
7	Status LED: <ul style="list-style-type: none"> Steady green: Normal operation Blinking green: Active warning Steady red: Active fault Blinking red: Active fault, set power to off to reset.

The user interface in brief:

- In the *Home* view, push the *Back* key to open the *Options* view.
- In the *Home* view, push the *OK* key to open the *Menu*.
- Navigate the views with the arrow keys.

34 Operation principle and hardware description

- Push the *OK* key to open the highlighted setting or item.
- Use the left and right arrow keys to highlight a value.
- Use the up and down arrow keys to set a value.
- Push the *Back* key to cancel a setting or return to the previous view.

■ Home view

The *Home* view shows the reading of one of three measured signals. Select the page with the left and right arrow keys.









The status bar at the top of the *Home* view shows:

- The control location (*Loc* for local control and *Rem* for remote control)
- The status icons
- The reference target value.

From the Home view, push the *Back* key to open the *Options* view and push the *OK* key to open the *Menu*.

Adjust the current reference value with the up and down arrow keys.

Status icon

Icon	Animation	Description
	None	Local Start/Stop enabled
	None	Stopped
	None	Stopped, start inhibited
	Blinks	Stopped, start commanded but inhibited
	Rotates	Running at reference
	Rotates	Running but not at reference
	Blinks	Running at reference, but reference = 0
	Blinks	Drive fault
	None	Local reference setting enabled

■ **Message view**

For fault and warning information, refer to the *ACS180 Firmware manual* (3AXD50000467860 [English]).

To reset a fault, push the *OK* key (with the soft-key label *Reset?*).

■ **Options view**

To open the *Options* view, push the *Back* key in the *Home* view.

In the *Options* view, you can:

- Set the control location
- Set the direction of the motor
- Set the reference
- View the active fault
- View a list of the active warnings.

■ **Menu**

To open the *Menu*, push the *OK* key in the *Home* view.

To navigate in the *Menu*, push the up and down arrow keys to move between menu items.

Menu items:

- *Motor data view*: Enter the motor specifications.
 - *Motor control view*: Set the motor control settings.
 - *Control macros view*: Select the connection parameter macro.
 - *Diagnostics view*: Read the active faults and warnings.
 - *Parameters view*: Open and edit the full list of parameters.
-

4

Mechanical installation

Contents of this chapter

The chapter tells you how to examine the installation site, unpack, check the delivery and install the drive mechanically.

Installation alternatives

You can install the drive onto an assembly plate with screws.

Installation requirements:

- Make sure that there is a minimum of 75 mm of free space at the top and bottom of the drive (at the cooling air inlet and outlet).
- You can install several drives side by side.
- If you install frame R0 drives side-by-side, the maximum ambient temperature is 40°C.
- Install frame R0 drives upright. Frame R0 drive does not have a cooling fan.
- You can install frame R1-R4 drives tilted by up to 90 degrees, from vertical to fully horizontal orientation.

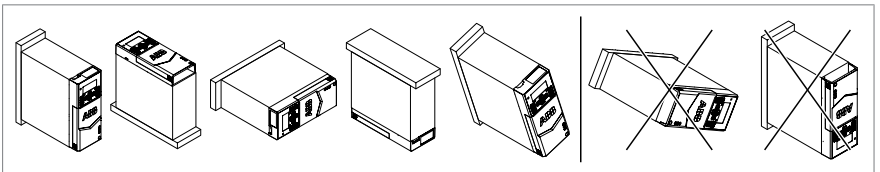

38 Mechanical installation

- Make sure that the hot cooling air from a drive does not go into the cooling air inlet of other equipment.
- Install the drive inside a cabinet or enclosure. The drive has an IP20 (UL Open Type) ingress protection classification for cabinet installation.

Examining the installation site

Examine the installation site. Make sure that:

- The installation site is sufficiently ventilated or cooled to remove heat from the drive. See the technical data.
- The ambient conditions of the drive meet the specifications. See the technical data.
- The material behind, above and below the drive is non-flammable.
- The installation surface is as close to vertical as possible and strong enough to support the drive.
- There is sufficient free space around the drive for cooling, maintenance, and operation. See the free space specifications for the drive.
- Make sure that there are no sources of strong magnetic fields such as high-current single-core conductors or contactor coils near the drive. A strong magnetic field can cause interference or inaccuracy in the operation of the drive.



Required tools

To install the drive mechanically, you need these tools:

- a drill and suitable drill bits
- a screwdriver or wrench with a set of suitable bits
- a tape measure and spirit level
- personal protective equipment.

Unpacking the delivery

The figure shows the drive package with its contents. Make sure that all of the items are present and that there are no signs of damage.

Package contents:

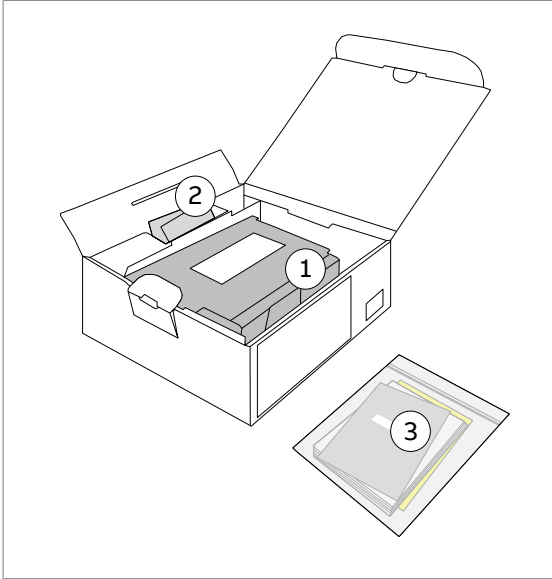

1. drive
2. installation accessories (cable clamps, metal grounding plate, screws, etc.)
3. quick installation and start-up guide.



Installing the drive

You can install the drive:

- With screws to a suitable surface (wall or assembly plate).
- To a DIN installation rail with the integrated lock for frame sizes R3 and R4.

■ To install the drive with screws

1. Make marks onto the surface for the mounting holes. See the diagram below and [Dimensions and weights](#) (page 108).
2. Make the holes for the mounting screws, and fasten the screws. Use plugs or anchors if needed. See section [Dimensions and weights](#) (page 108) for the max. screw diameter.

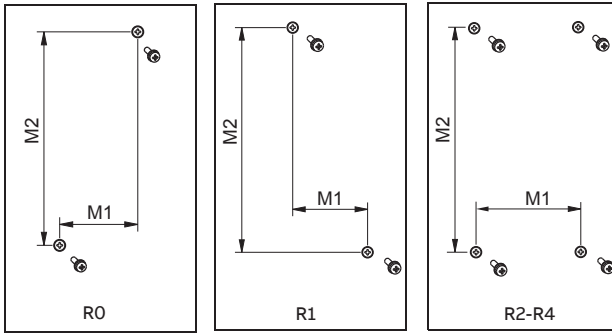

Frame size	M1		M2	
	mm	in	mm	in
R0	60	2.36	164	6.46
R1	60	2.36	180	7.09
R2	106	4.17	190.5	7.5
R3	148	5.83	191	7.52
R4	234	9.21	191	7.52

3. Install the drive onto the mounting screws.



4. Tighten the mounting screws.

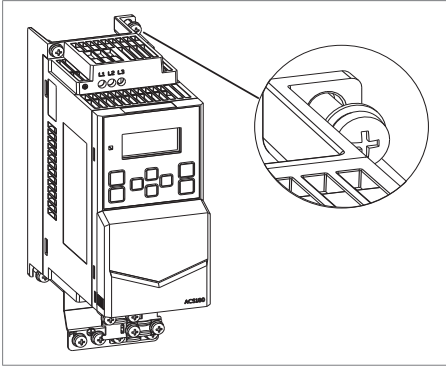

■ **To install the drive to a DIN installation rail for frame sizes R3 and R4**

Use an IEC/EN 60715 top hat type installation rail, width × height = 35 × 7.5 mm (1.4 × 0.3 in).

1. Move the locking part to the left.

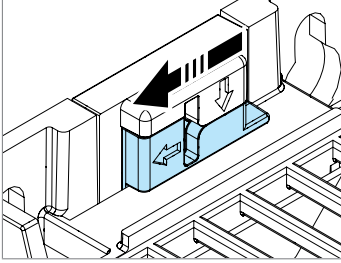

2. Push and hold the locking button down.

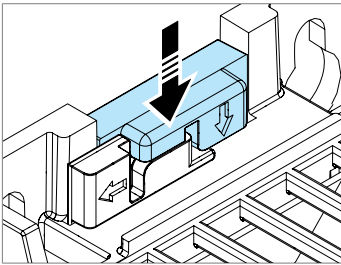

3. Put the top tabs of the drive onto the top edge of the DIN installation rail.
4. Put the drive against the bottom edge of the DIN installation rail.
5. Release the locking button.
6. Move the locking part to the right.
7. Make sure that the drive is correctly installed.

To move the drive, use a flat-head screwdriver to open the locking part.



5

Guidelines for planning the electrical installation

Contents of this chapter

This chapter contains guidelines for planning the electrical installation of the drive.

Limitation of liability

The installation must always be designed and made according to applicable local laws and regulations. ABB does not assume any liability whatsoever for any installation which breaches the local laws and/or other regulations. Furthermore, if the recommendations given by ABB are not followed, the drive may experience problems that the warranty does not cover.

Selecting the main supply disconnecting device

You must equip the drive with a main supply disconnecting device which meets the local safety regulations. You must be able to lock the disconnecting device to the open position for installation and maintenance work.

■ European Union and United Kingdom

To comply with European Union directives and United Kingdom regulations related to standard EN 60204-1, the disconnecting device must be one of these types:

- switch-disconnector of utilization category AC-23B (IEC 60947-3)
- disconnector that has an auxiliary contact that in all cases causes switching devices to break the load circuit before the opening of the main contacts of the disconnector (EN 60947-3)
- circuit-breaker suitable for isolation in accordance with IEC 60947-2.

■ North America

Installations must be compliant with NFPA 70 (NEC)¹⁾ and/or Canadian Electrical Code (CE) along with state and local codes for your location and application.

¹⁾ National Fire Protection Association 70 (National Electric Code).

■ Other regions

The disconnecting device must conform to the applicable local safety regulations.

Selecting the main contactor

You can equip the drive with a main contactor.

Follow these guidelines when you select a main contactor:

- Dimension the contactor according to the nominal voltage and current of the drive. Also consider the environmental conditions such as surrounding air temperature.
- Select contactor with utilization category AC-1 (number of operations under load) according to IEC 60947-4, *Low-voltage switch gear and control gear*.
- Consider the application life time requirements.

Checking the compatibility of the motor and drive

Use asynchronous AC induction motor, or permanent magnet synchronous motor with the drive. Multiple induction motors can be connected to the drive at a time when using the scalar motor control mode.

Make sure that the motor(s) and the drive are compatible according to the rating table in the technical data.

Selecting the power cables

■ General guidelines

Select the input power and motor cables according to local regulations.

- **Current:** Select a cable capable of carrying the maximum load current and suitable for the prospective short-circuit current provided by the supply network. The method of installation and ambient temperature affect the cable current carrying capacity. Obey local regulations and laws.
- **Temperature:** For an IEC installation, select a cable rated for at least 70 °C (158 °F) maximum permissible temperature of conductor in continuous use. For North America, select a cable rated for at least 75 °C (167 °F).
Important: For certain product types or option configurations higher temperature rating may be required. See the technical data for details.
- **Voltage:** 600 V AC cable is accepted for up to 500 V AC. 750 V AC cable is accepted for up to 600 V AC. 1000 V AC cable is accepted for up to 690 V AC.

To comply with the EMC requirements of the CE mark, use one of the preferred cable types. See [Preferred power cable types](#) (page 45).

Symmetrical shielded cable reduces electromagnetic emission of the whole drive system as well as the stress on motor insulation, bearing currents and wear.

Metal conduit reduces electromagnetic emission of the whole drive system.

■ Typical power cable sizes

See the technical data.

■ Power cable types

Preferred power cable types

This section presents the preferred cable types. Make sure that the selected cable type also complies with local/state/country electrical codes.

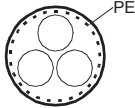

Cable type	Use as input power cabling	Use as motor cabling and as brake resistor cabling
 <p>Symmetrical shielded (or armored) cable with three phase conductors and concentric PE conductor as shield (or armor)</p>	Yes	Yes

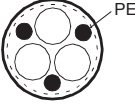
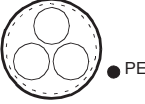
46 Guidelines for planning the electrical installation

Cable type	Use as input power cabling	Use as motor cabling and as brake resistor cabling
 <p>Symmetrical shielded (or armored) cable with three phase conductors and symmetrically constructed PE conductor and a shield (or armor)</p>	Yes	Yes
 <p>Symmetrical shielded (or armored) cable with three phase conductors and a shield (or armor), and separate PE conductor/cable¹⁾</p>	Yes	Yes

¹⁾ A separate PE conductor is required if the conductivity of the shield (or armor) is not sufficient for the PE use.

Alternate power cable types

Cable type	Use as input power cabling	Use as motor cabling and as brake resistor cabling
 <p>Four-conductor cabling in PVC conduit or jacket (three phase conductors and PE)</p>	Yes with phase conductor smaller than 10 mm ² (8 AWG) Cu.	Yes with phase conductor smaller than 10 mm ² (8 AWG) Cu, or motors up to 30 kW (40 hp). Note: Shielded or armored cable, or cabling in metal conduit is always recommended to minimize radio frequency interference.
 <p>Four-conductor cabling in metal conduit (three phase conductors and PE). For example, EMT, or four-conductor armored cable</p>	Yes	Yes with phase conductor smaller than 10 mm ² (8 AWG) Cu, or motors up to 30 kW (40 hp)

Cable type	Use as input power cabling	Use as motor cabling and as brake resistor cabling
 <p>Shielded (Al/Cu shield or armor)¹⁾ four-conductor cable (three phase conductors and a PE)</p>	Yes	Yes with motors up to 100 kW (135 hp). A potential equalization between the frames of motor and driven equipment is required.

¹⁾ Armor may act as an EMC shield, as long as it provides the same performance as a concentric EMC shield of a shielded cable. To be effective at high frequencies, the shield conductivity must be at least 1/10 of the phase conductor conductivity. The effectiveness of the shield can be evaluated based on the shield inductance, which must be low and only slightly dependent on frequency. The requirements are easily met with a copper or aluminum shield/armor. The cross-section of a steel shield must be ample and the shield helix must have a low gradient. A galvanized steel shield has a better high-frequency conductivity than a non-galvanized steel shield.

Not allowed power cable types

Cable type	Use as input power cabling	Use as motor cabling and as brake resistor cabling
 <p>Symmetrical shielded cable with individual shields for each phase conductor</p>	No	No

■ **Additional guidelines, North America**

ABB recommends the use of metallic conduit for power wiring. ABB also recommends the use of symmetrical shielded VFD cable between drive and motor(s).

This table shows examples of methods for wiring the drive. Refer to NEC 70 along with state and local codes for the appropriate methods for your application.

Wiring method	Notes
Conduit - Metallic ^{1) 2)}	
Electrical metallic tubing: Type EMT	Prefer symmetrical shielded VFD cable.
Rigid metal conduit: Type RMC	Use separate conduit run for each motor.
Liquid-tight flexible metal electrical conduit: Type LFMC	Do not run input power wiring and motor wiring in the same conduit.
Conduit - Non-metallic ^{2) 3)}	
Liquid-tight flexible non-metallic conduit: Type LFNC	Prefer symmetrical shielded VFD cable. Use separate conduit run for each motor. Do not run input power wiring and motor wiring in the same conduit.
Wireways ²⁾	
Metallic	Prefer symmetrical shielded VFD cable. Separate motor wiring from input power wiring and other low voltage wiring. Do not run outputs of multiple drives parallel. Bundle each cable (wiring) together and use separators where possible.
Free air ²⁾	
Enclosures, air handlers, etc.	Prefer symmetrical shielded VFD cable. Allowed internally in enclosures when in accordance with UL.

1) Metallic conduit may be used as an additional ground path, provided this path is a solid path capable of handling ground currents.

2) See NFPA NEC 70, UL, and local codes for your application.

3) Non-metallic conduit use underground is allowed; however, these installations inherently have an increased chance for nuisance problems due to the potential for water/moisture in the conduit. Water/moisture in the conduit increases the likelihood of VFD faults or warnings. Proper installation is required to make sure there is no intrusion of water/moisture.

Metal conduit

Couple separate parts of a metal conduit together: bridge the joints with a ground conductor bonded to the conduit on each side of the joint. Also bond the conduits to the drive enclosure and motor frame. Use separate conduits for input power, motor, brake resistor, and control wiring. Do not run motor wiring from more than one drive in the same conduit.

■ Power cable shield

If the cable shield is used as the sole protective earth (PE) conductor, make sure that its conductivity agrees with the PE conductor requirements.

To effectively suppress radiated and conducted radio-frequency emissions, the cable shield conductivity must be at least 1/10 of the phase conductor conductivity. The requirements are easily met with a copper or aluminum shield. The minimum

requirement of the motor cable shield of the drive is shown below. It consists of a concentric layer of copper wires with an open helix of copper tape or copper wire. The better and tighter the shield, the lower the emission level and bearing currents.

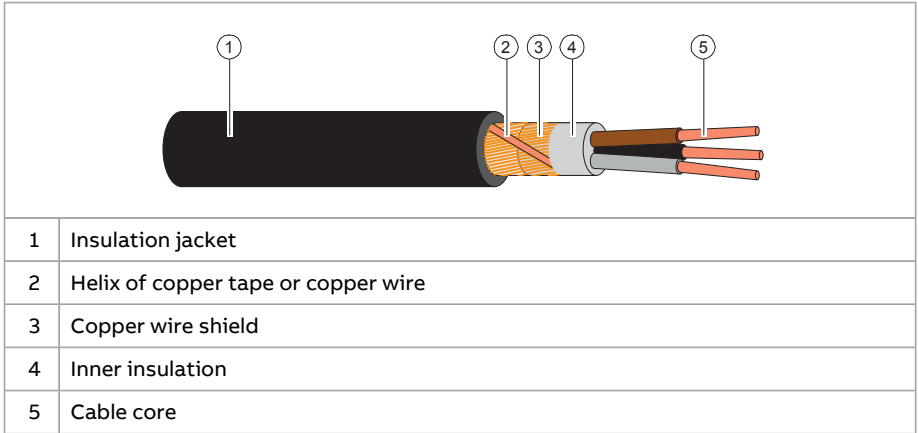

Selecting the control cables

■ Shielding

Only use shielded control cables.

Use a double-shielded twisted pair cable for analog signals. This type of cable is recommended for the pulse encoder signals also. Use one individually shielded pair for each signal. Do not use common return for different analog signals.

A double-shielded cable (a) is the best alternative for low-voltage digital signals, but single-shielded (b) twisted pair cable is also acceptable.

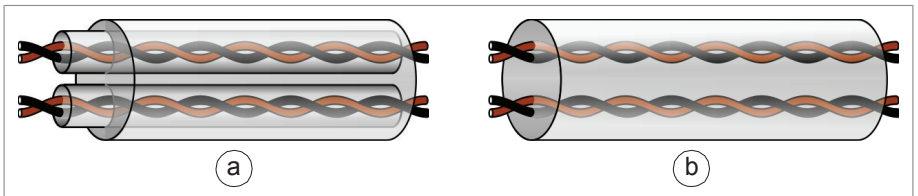

■ Signals in separate cables

Run analog and digital signals in separate, shielded cables. Do not mix 24 V DC and 115/230 V AC signals in the same cable.

■ Signals that can be run in the same cable

If their voltage does not exceed 48 V, relay-controlled signals can be run in the same cables as digital input signals. The relay-controlled signals should be run as twisted pairs.

■ Relay cable

Recommend to use the cable type with braided metallic shield.

■ Control panel to drive cable

Use EIA-485 with male RJ-45 connector, cable type Cat 5e or better. The maximum permitted length of the cable is 100 m (328 ft).

■ PC tool cable

Connect the Drive composer PC tool to the drive through the USB port of the external assistant control panel. Use a USB Type A (PC) - Type Mini-B (control panel) cable. The maximum length of the cable is 3 m (9.8 ft) or use the BCBL-01 USB to EIA-485 cable to connect the drive with PC directly. .

Routing the cables

■ General guidelines – IEC

- Route the motor cable away from other cables. Motor cables of several drives can be run in parallel installed next to each other.
- Install the motor cable, input power cable and control cables on separate trays.
- Avoid long parallel runs of motor cables with other cables.
- Where control cables must cross power cables, make sure that they are arranged at an angle as near to 90 degrees as possible.
- Do not run extra cables through the drive.
- Make sure that the cable trays have good electrical bonding to each other and to the grounding electrodes. Aluminum tray systems can be used to improve local equalizing of potential.

The following figure illustrates the cable routing guidelines with an example drive.

Note: When motor cable is symmetrical and shielded and it has short parallel runs with other cables (< 1.5 m / 5 ft), distances between the motor cable and other cables can be reduced by half.

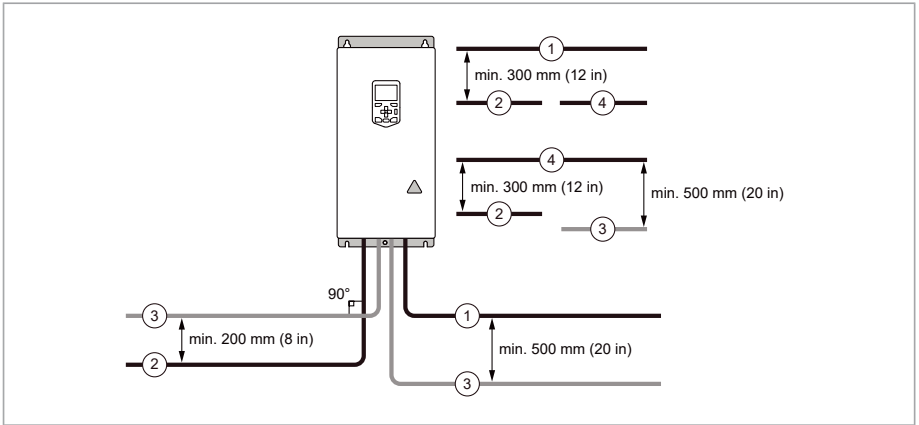

1	Motor cable
2	Input power cable
3	Control cable
4	Brake resistor or chopper cable (if any)

■ **General guidelines – North America**

Make sure that the installation is in accordance with national and local codes. Obey these general guidelines:

- Use separate conduits for the input power, motor, brake resistor (optional), and control cabling.
- Use separate conduit for each motor cabling.

The following figure illustrates the cable routing guidelines with an example drive.

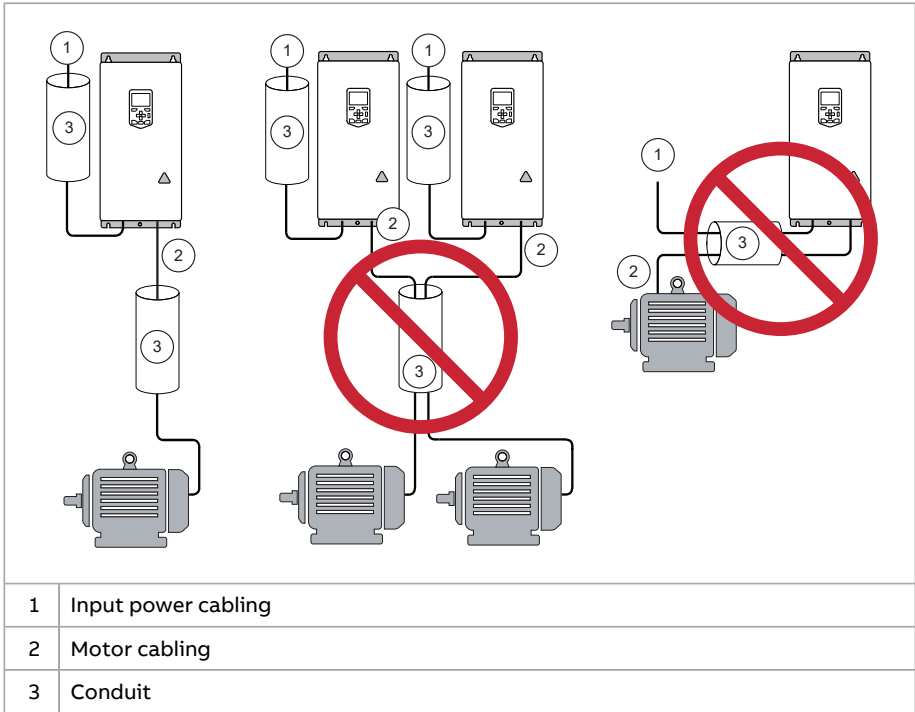

■ **Continuous motor cable shield/conduit or enclosure for equipment on the motor cable**

To minimize the emission level when safety switches, contactors, connection boxes or similar equipment are installed on the motor cable between the drive and the motor:

- Install the equipment in a metal enclosure.
- Use either a symmetrical shielded cable, or install the cabling in a metal conduit.
- Make sure that there is a good and continuous galvanic connection in the shield/conduit between drive and motor.
- Connect the shield/conduit to the protective ground terminal of the drive and the motor.

■ Separate control cable ducts

Put 24 V DC and 230 V AC (120 V AC) control cables in separate ducts, unless the 24 V DC cable is insulated for 230 V AC (120 V AC) or insulated with an insulation sleeving for 230 V AC (120 V AC).

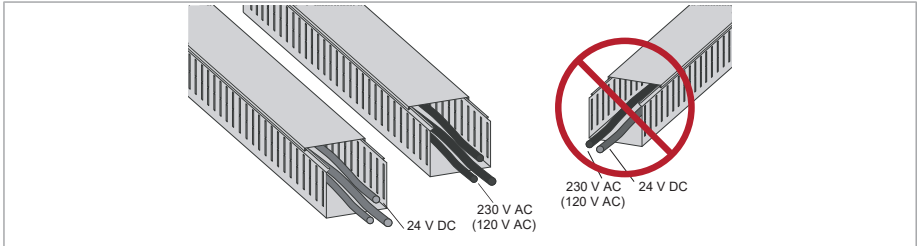

Implementing short-circuit and thermal overload protection

■ Protecting the drive and input power cable in short-circuits

Use the fuses specified for the drive in the technical data. Make sure that also the electric power supply network meets the specification (minimum allowed short-circuit current that the fuse selection is based on).

The fuses restrict drive damage and prevent damage to adjoining equipment in case of a short-circuit inside the drive. When located at the distribution board, the fuses also protect the input power cable against short circuits.

See the drive technical data for alternative short-circuit protections.

■ Protecting the motor and motor cable in short-circuits

The drive protects the motor cable and motor in a short-circuit situation when:

- the motor cable is sized correctly
- the motor cable type complies with the motor cable selection guidelines by ABB
- the cable length does not exceed the allowed maximum length specified for the drive
- the setting of parameter 99.10 Motor nominal power in the drive is equal with the value given on the motor rating plate.

The electronic power output short-circuit protection circuitry meets the requirements of IEC 60364-4-41 2005/AMD1.

■ **Protecting the drive, and the input power and motor cables against thermal overload**

If the cables have the correct size for the nominal current, the drive protects itself and the input and motor cables against thermal overload. No additional thermal protection devices are needed.



WARNING!

If the drive is connected to multiple motors, use a separate motor thermal overload device for protecting each motor cable and motor against overload. The drive overload protection is for the sum of the total motor load. It may not trip due to an overload in one motor.

■ **Protecting the motor against thermal overload**

According to regulations, the motor must be protected against thermal overload and the current must be switched off when overload is detected. The drive includes a motor thermal protection function that protects the motor and switches off the current when necessary. Depending on a drive parameter value, the function either monitors a calculated temperature value (based on a motor thermal model) or an actual temperature indication given by motor temperature sensors.

The motor thermal protection model supports thermal memory retention and speed sensitivity. The user can tune the thermal model further by feeding in additional motor and load data.

The most common temperature sensor types are PTC or Pt100.

For more information, see the firmware manual.

■ **Protecting the motor against overload without thermal model or temperature sensors**

Motor overload protection protects the motor against overload without using motor thermal model or temperature sensors.

Motor overload protection is required and specified by multiple standards including the US National Electric Code (NEC) and the common UL/IEC 61800-5-1 standard in conjunction with UL/IEC 60947-4-1. The standards allow for motor overload protection without external temperature sensors.

The protection feature of the drive allows the user to specify the class of operation in the same manner as the overload relays are specified in standards UL/IEC 60947-4-1 and NEMA ICS 2.

The motor overload protection supports thermal memory retention and speed sensitivity.

For more information, see drive firmware manual.

Implementing motor temperature sensor connection



WARNING!

IEC 61800-5-1 requires double or reinforced insulation between live parts and accessible parts when:

- the accessible parts are not conductive, or
- the accessible parts are conductive, but not connected to the protective earth.

Obey this requirement when you plan the connection of the motor temperature sensor to the drive.

You have these implementation alternatives:

1. If there is double or reinforced insulation between the sensor and the live parts of the motor: You can connect the sensor directly to the analog/digital input(s) of the drive. See the control cable connection instructions.
2. If there is basic insulation between the sensor and the live parts of the motor: You can connect the sensor to the analog/digital input(s) of the drive. All other circuits connected to the digital and analog inputs (typically extra-low voltage circuits) must be:
 - protected against contact, and
 - insulated with basic insulation from other low-voltage circuits. The insulation must be rated for the same voltage level as the drive main circuit.

Note: Extra-low voltage circuits (for example, 24 V DC) typically do not meet these requirements.

As an alternative, you can connect the sensor with basic insulation to the analog/digital input(s) of the drive, if you do not connect any other external control circuits to the drive digital and analog inputs.

3. You can connect a sensor to a digital input of the drive via an external relay. The sensor and the relay must form a double or reinforced insulation between the motor live parts and the digital input of the drive.

Protecting the drive against ground faults

The drive is equipped with an internal ground fault protective function to protect the unit against ground faults in the motor and motor cable. This function is not a personnel safety or a fire protection feature. See the firmware manual for more information.

■ Residual current device compatibility

The drive is suitable for use with residual current devices of Type B.

Note: As standard, the drive contains capacitors connected between the main circuit and the frame. These capacitors and long motor cables increase the ground leakage current and may cause nuisance faults in residual current devices.

Implementing the Emergency stop function

For safety reasons, install the emergency stop devices at each operator control station and at other operating stations where emergency stop may be needed. Design the emergency stop according to the applicable standards.

You can use the Safe torque off function of the drive to implement the Emergency stop function.

Note: Pressing the stop (off) key on the control panel of the drive does not generate an emergency stop of the motor or separate the drive from dangerous potential.

Implementing the Safe torque off function

See chapter [The Safe torque off function \(page 143\)](#).

Using a safety switch between the drive and the motor

ABB recommends to install a safety switch between the permanent magnet motor and the drive output. The switch is needed to isolate the motor from the drive during maintenance work on the drive.

Implementing the control of a contactor between drive and motor

Implementing the control of the output contactor depends on the motor control mode and stopping method selected.

When you select the vector motor control mode and the motor ramp stop mode, use this operation sequence to open the contactor:

1. Give a stop command to the drive.
2. Wait until the drive decelerates the motor to zero speed.
3. Open the contactor.



WARNING!

If vector motor control mode is in use, do not open the output contactor while the drive controls the motor. The motor control operates faster than the contactor, and tries to maintain the load current. This can cause damage to the contactor.

When you select the vector motor control mode and the motor coast stop mode, you can open the contactor immediately after the drive has received the stop command. This is the case also if you use the scalar motor control mode.

Protecting the contacts of relay outputs

Inductive loads (relays, contactors, motors) cause voltage transients when switched off.

Install the protective component as close to the inductive load as possible. Do not install protective components at the relay outputs.

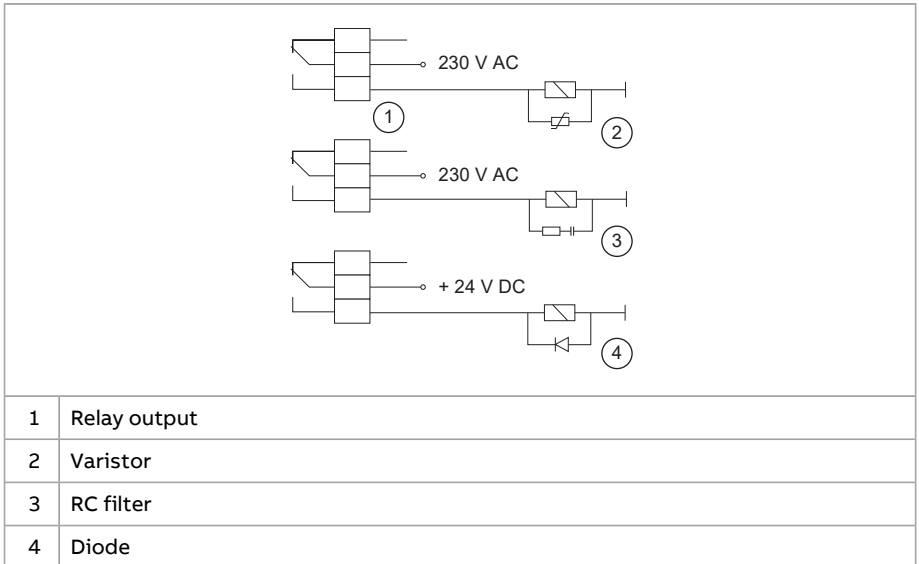

6

Electrical installation

Contents of this chapter

This chapter describes how to:

- measure the insulation
- do an earthing system compatibility check
- change the EMC filter connection
- connect the power and control cables
- install optional modules
- connect a PC.

Warnings

**WARNING!**

Obey the safety instructions of the drive. If you ignore them, injury or death, or damage to the equipment can occur. If you are not a qualified electrical professional, do not do installation, commissioning or maintenance work.

Required tools

To do the electrical installation, you need the following tools:

- wire stripper
-



- screwdriver or wrench with a set of suitable bits. For motor cable terminals, the recommended screwdriver shaft length is 150 mm (5.9 in).
- short flat head screwdriver for the I/O terminals
- torque wrench
- voltage tester
- insulation resistance meter
- personal protective equipment.

Measuring the insulation

■ Measuring the insulation resistance of the drive



WARNING!

Do not do any voltage withstand or insulation resistance tests on any part of the drive as testing can damage the drive. Every drive has been tested for insulation between the main circuit and the chassis at the factory. Also, there are voltage-limiting circuits inside the drive which cut down the testing voltage automatically.

■ Measuring the insulation resistance of the input power cable

Before you connect the input power cable to the drive, measure its insulation resistance according to local regulations.

■ Measuring the insulation resistance of the motor and motor cable



WARNING!

Obey the safety instructions of the drive. If you ignore them, injury or death, or damage to the equipment can occur. If you are not a qualified electrical professional, do not do installation, commissioning or maintenance work.

1. Do the steps in section [Electrical safety precautions \(page 16\)](#) before you start the work.
 2. Make sure that the motor cable is disconnected from the drive output terminals.
 3. Measure the insulation resistance between each phase conductor and the protective earth conductor. Use a measuring voltage of 1000 V DC. The insulation resistance of an ABB motor must be more than 100 Mohm (reference value at 25 °C [77 °F]). For the insulation resistance of other motors, refer to the manufacturer's instructions.
-



Note: Moisture inside the motor reduces the insulation resistance. If you think that there is moisture in the motor, dry the motor and do the measurement again.

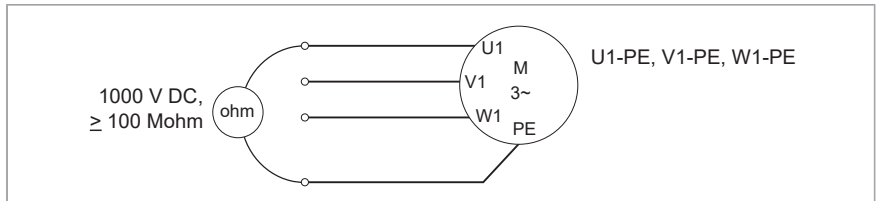

Earthing system compatibility check

■ EMC filter

The drive ACS180-04S-...-1/4 has an internal EMC filter as standard. You can install the drive to a symmetrically grounded TN-S system. If you install the drive to another system, you must disconnect the EMC filter.

Note: If you disconnect the EMC filter, the electromagnetic compatibility of the drive decreases.



WARNING!

Do not install a drive with the internal EMC filter connected to a grounding system that the EMC filter is not compatible with (for example, an IT system). The supply network becomes connected to ground potential through the internal EMC filter capacitors, which can cause danger or damage to the drive.

■ When to disconnect the EMC filter

The table shows different earthing systems, and when you need to disconnect the EMC filter (metal EMC screw).





WARNING!

Remove the metal EMC screw in systems other than the symmetrically grounded TN-S systems. If you do not, it can cause danger or damage to the drive.

Screw label	Screw material	When to remove EMC screw or VAR screw		
		Symmetrically grounded TN-S systems, i.e. center-grounded wye (A)	Corner-grounded delta (B1), mid-point-grounded delta (B2) and TT (D) systems	IT systems (ungrounded or highresistance grounded) (C)
EMC	Metal	Do not remove	Remove	Remove
	Plastic	Do not remove ¹⁾	Do not remove	Do not remove
VAR	Metal	Do not remove	Do not remove	Remove
	Plastic	Do not remove	Do not remove	Do not remove

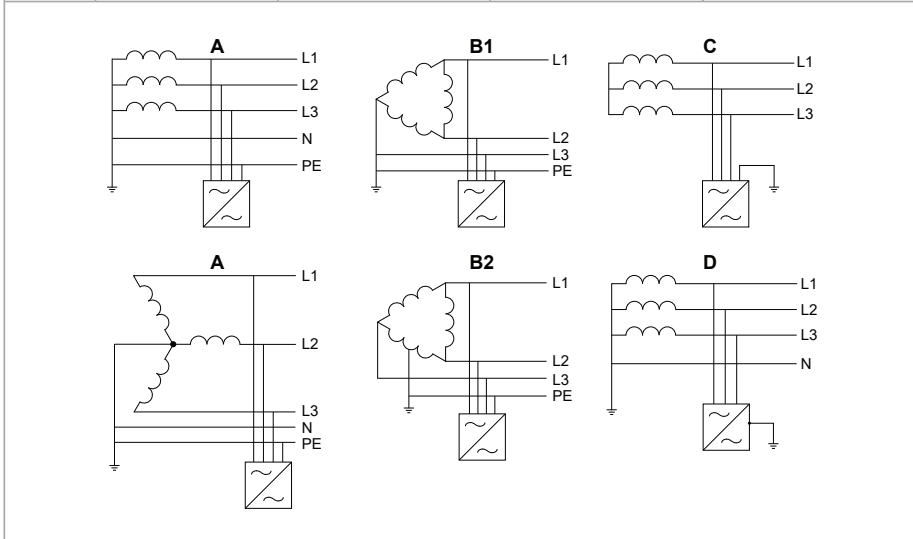

¹⁾ Can install the metal screw included in the drive delivery to connect the internal EMC filter.

Note: ACS180-04N-...-4 drives do not support corner-grounded delta (B1) system.

■ **Disconnecting the EMC filter**

1. Do the steps in section [Electrical safety precautions \(page 16\)](#) before you start the work.

- To disconnect the EMC filter, remove the metal EMC screw. The location vary. See the Layout (page 27).

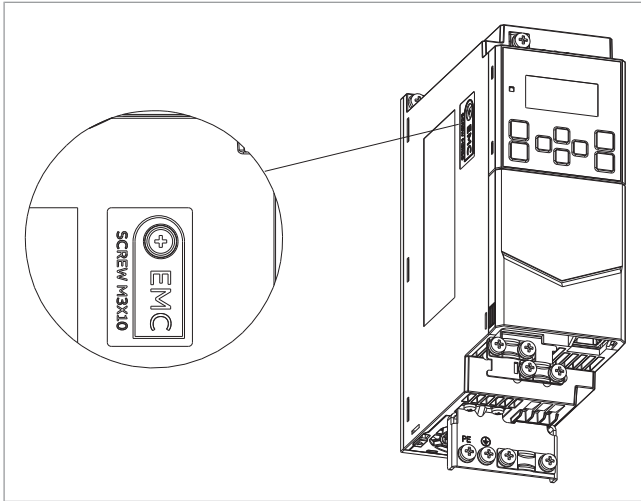

■ Guidelines for installing the drive to a TT system

You can install the drive to a TT system under these conditions:

- There is a residual current device in the supply system
- The internal EMC filter is disconnected. If the EMC filter is not disconnected, its leakage current will cause the residual current device to trip.

Note:

- ABB does not guarantee the EMC performance, because the internal EMC filter is disconnected.
- ABB does not guarantee the functioning of the ground leakage detector built inside the drive.
- In large systems the residual current device can trip without a real reason.

■ Identifying the grounding system of the electrical power network



WARNING!

Only a qualified electrical professional may do the work instructed in this section. Depending on the installation site, the work may even be categorized as live working. Continue only if you are an electrical professional certified for the work. Obey the local regulations. If you ignore them, injury or death can occur.

64 Electrical installation

To identify the grounding system, examine the supply transformer connection. See the applicable electrical diagrams of the building. If that is not possible, measure these voltages at the distribution board, and use the table to define the grounding system type.

1. input voltage line to line (U_{L-L})
2. input voltage line 1 to ground (U_{L1-G})
3. input voltage line 2 to ground (U_{L2-G})
4. input voltage line 3 to ground (U_{L3-G}).

The table below shows the line-to-ground voltages in relation to the line-to-line voltage for each grounding system.

U_{L-L}	U_{L1-G}	U_{L2-G}	U_{L3-G}	Electrical power system type
X	$0.58 \cdot X$	$0.58 \cdot X$	$0.58 \cdot X$	Symmetrically grounded TN system (TN-S system)
X	$1.0 \cdot X$	$1.0 \cdot X$	0	Corner-grounded delta system (nonsymmetrical)
X	$0.866 \cdot X$	$0.5 \cdot X$	$0.5 \cdot X$	Midpoint-grounded delta system (nonsymmetrical)
X	Varying level versus time	Varying level versus time	Varying level versus time	IT systems (ungrounded or high-resistance-grounded [>30 ohms]) nonsymmetrical
X	Varying level versus time	Varying level versus time	Varying level versus time	TT system (the protective earth connection for the consumer is provided by a local earth electrode, and there is another independently installed at the generator)



Connecting the power cables

■ Connection diagram

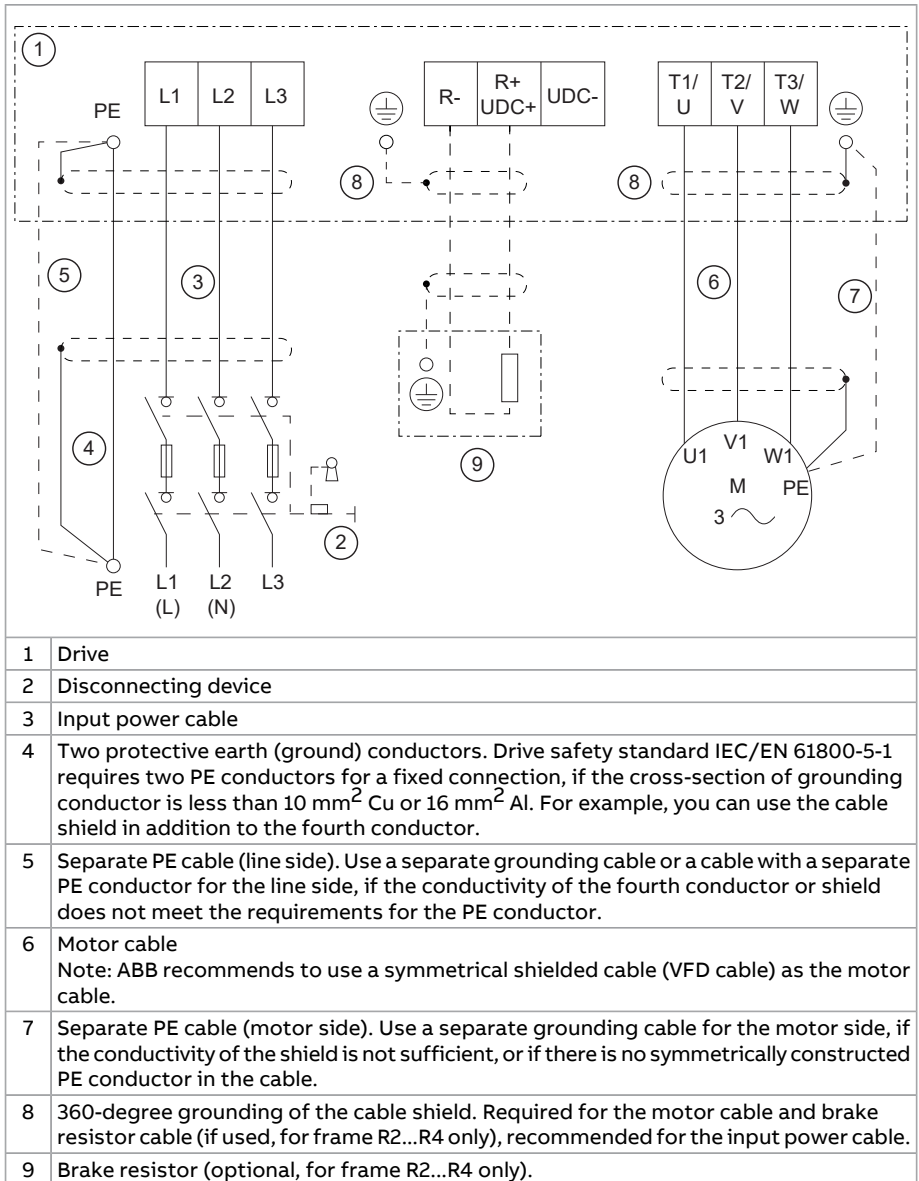

■ Connection procedure



WARNING!

Obey the safety instructions of the drive. If you ignore them, injury or death, or damage to the equipment can occur. If you are not a qualified electrical professional, do not do installation, commissioning or maintenance work.

1. Stop the drive and do the steps in section **Electrical safety precautions** (page 16) before you start the work.
2. Install the grounding plate and fasten it with screw.

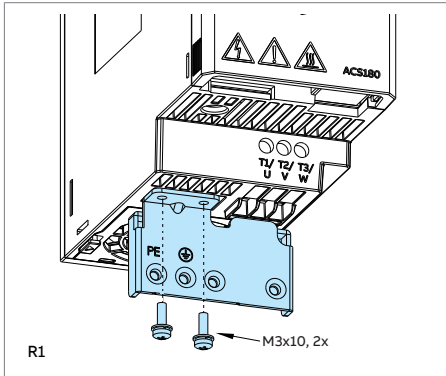
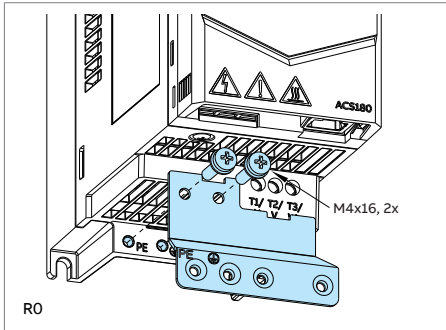

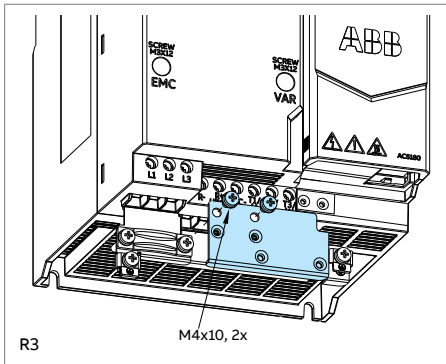

3. Strip the motor cable.
4. Ground the motor cable shield under the grounding clamp.

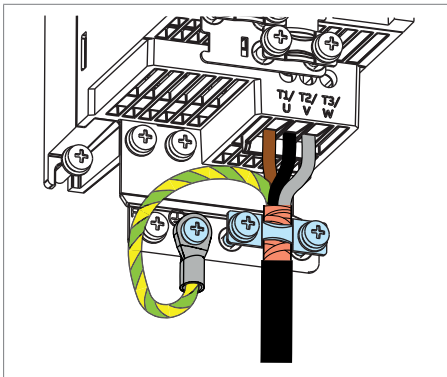

5. Twist the motor cable shield into a bundle, mark it with yellow-green and connect it to the grounding terminal.
6. Connect the phase conductors of the motor cable to the T1/U, T2/V and T3/W motor terminals.
7. For frame sizes R2-R4, if you use a brake resistor, connect the brake resistor cable to the R- and UDC+ terminals. Use shielded cable and ground the shield under the grounding clamp (360-degree grounding).
8. Strip the input power cable.



9. If the input power cable has a shield, twist it into a bundle, mark it with yellow-green and connect it to the PE terminal.

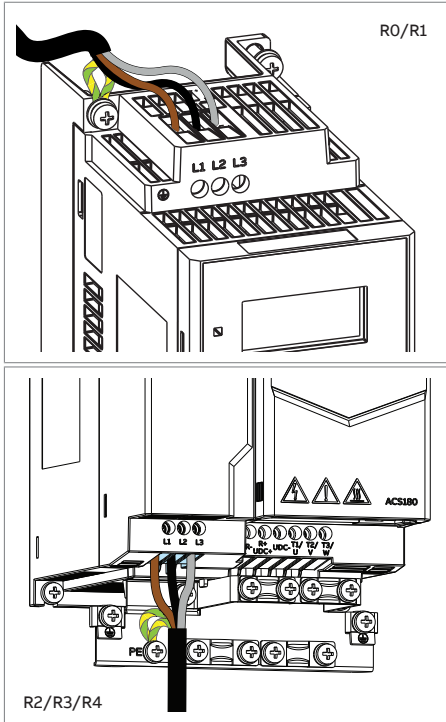

10. Mark the second grounding connector of the input side with the yellow-green and connect it to the PE terminal. (Second PE conductor is required by the drive safety standards IEC61800-5 and UL 61800-5.)
11. Connect the phase conductors of the input power cable to the L1, L2 and L3 input terminals.
12. Mechanically attach the cables on the outside of the drive.

Connecting the control cables

Refer to Default I/O connection diagram (ABB standard macro) for the default I/O connections of the ABB standard macro. For other macros, refer to the *ACS180 firmware manual* (3AXD50000467860 [English]).

■ Default I/O connection diagram (ABB standard macro)

Connection	Term. ¹⁾	Description	
Digital I/O			
	21	24 V	
	22	DGND	
	8	DI1	
	9	DI2	
	10	DI3	
	11	DI4	
	12	DCOM	
	18	DO	
	19	DO COM	
	20	DO SRC	
	Analog I/O		
		14	AI1/DI5
13		AGND	
15		AI2	
16		AGND	
17		AO	
23		10V	
24		SCREEN	
Safe torque off (STO)(only on ACS180-04S)			
	1	S+	
	2	SGND	
	3	S1	
	4	S2	
Relay output			
	5	NC	
	6	COM	
	7	NO	
EIA-485 Modbus RTU			
25	B+	Embedded Modbus RTU (EIA-485)	
26	A-		
27	AGND		
28	SHIELD		
Jumper			
J1	Termination	Modbus termination selection	
J2	Comm.Mode	Communication mode selection	

1) Terminal size: 0.5 mm² ... 1 mm²

■ Control cable connection procedure

Do the connections according to the macro in use.

Keep the signal wire pairs twisted as near to the terminals as possible to prevent inductive coupling.



WARNING!

Obey the safety instructions of the drive. If you ignore them, injury or death, or damage to the equipment can occur. If you are not a qualified electrical professional, do not do installation, commissioning or maintenance work.

1. Stop the drive and do the steps in section [Electrical safety precautions](#) (page 16) before you start the work.
2. Remove the front cover.
3. Insert the grounding clamp into the slot and fasten it with screw.

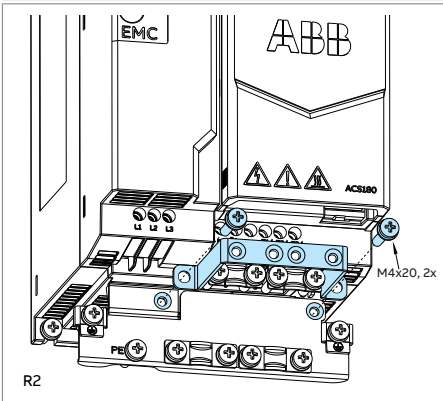
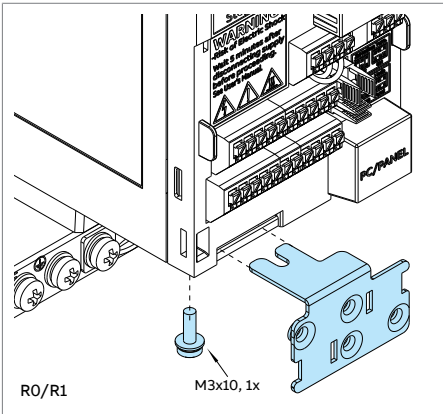

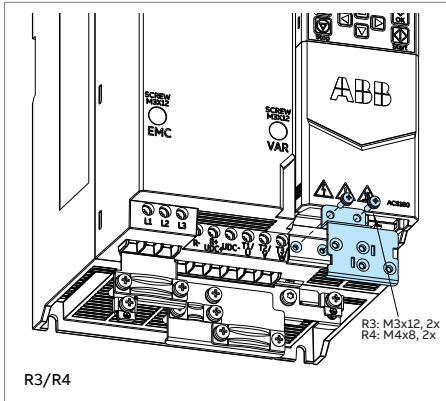

4. Strip a part of the outer shield of the control cable for 360-degree grounding.
5. Use a 360-degree grounding clamp to connect the cable to the grounding tab.
6. Strip the ends of the control cable conductors. For stranded (multi-wire) conductors, install ferrules at the bare conductor ends.
7. Connect the conductors to the correct control terminals.
8. Mechanically attach the control cables on the outside of the drive.

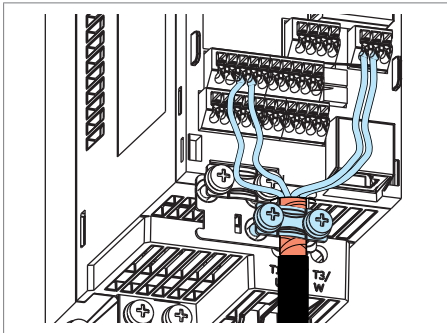

Additional information on the control connections

■ Connecting EIA-485 fieldbus cable to the drive

Connect the fieldbus to the EIA-485 Modbus RTU terminal on the front of the drive. The EIA-485 network uses shielded, twisted-pair cable for data signaling with characteristic impedance between 100 and 130 ohm. The distributed capacitance between conductors is less than 100 pF per meter (30 pF per foot). Distributed capacitance between conductors and shield is less than 200 pF per meter (60 pF per foot). Foil or braided shields are acceptable. The connection diagram is shown below.

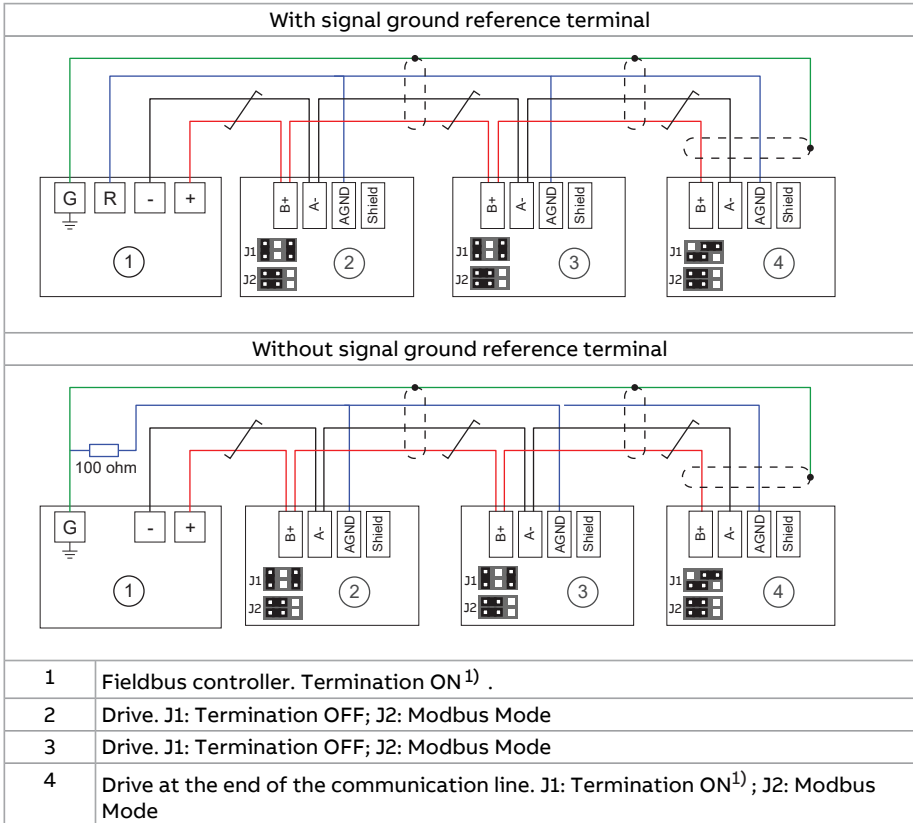

¹⁾ **Note:** The device at both ends on the fieldbus must have termination set to ON.

■ PNP configuration for digital inputs

Internal and external +24 V power supply connections for PNP (source) configuration are shown in the figure below.

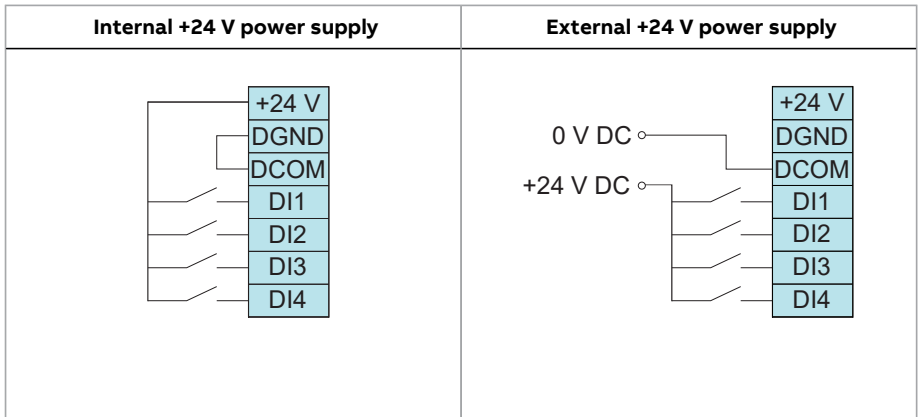

■ NPN configuration for digital inputs

Internal and external +24 V power supply connections for NPN (sink) configuration are shown in the figure below.

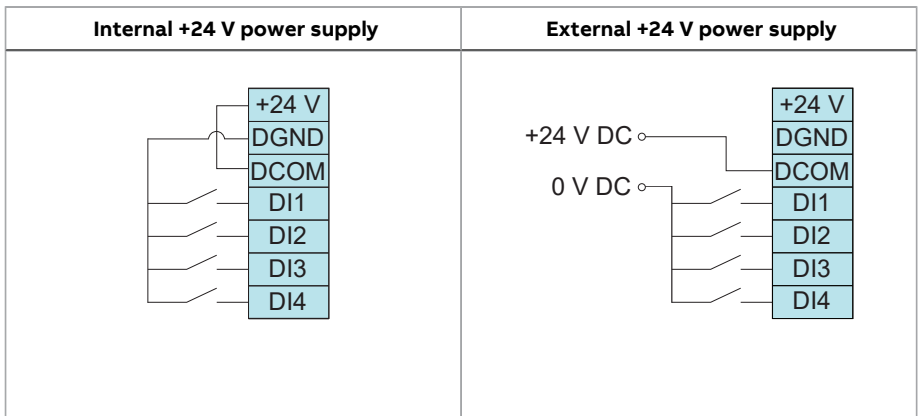

■ **Connection examples of two-wire and three-wire sensors**

The figures give examples of connections for a two-wire or three-wire sensor/transmitter that is supplied by the auxiliary voltage output of the drive.

AI2	Process actual value measurement or reference, 4 ... 20 mA, $R_{iN} = 205 \text{ ohm}$.
AGND	Note: The sensor power supply comes through its current output circuit, use 4 ... 20 mA signal, not 0 ... 20 mA.
+24V	Auxiliary voltage output, non-isolated, +24 V DC, max. 100 mA
DGND	

AI2	Process actual value measurement or reference, 0(4)...20 mA, $R_{iN} = 205 \text{ ohm}$
AGND	
+24V	Auxiliary voltage output, non-isolated, +24 V DC, max. 100 mA
DGND	

■ **Safe torque off**

For the drive to start, both STO connections must be closed. By default, the terminal block has jumpers to close the circuit. Remove the jumpers before connecting external Safe torque off circuitry to the drive. See chapter [The Safe torque off function](#).

■ **Communication mode jumper J2**

When you need to connect a PC or an assist control panel to the drive, set:

- Jumper J2 on the front of the drive = Panel (default)

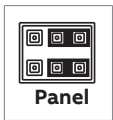

- Parameter 58.01 (protocol enable) = 0 (None, default)

When you need to use Modbus RTU communication with the drive, set:

- Jumper J2 on the front of the drive = Modbus

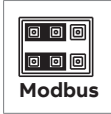

- Parameter 58.01 (protocol enable) = 1 (Modbus RTU)

Connecting a PC

To connect a PC to the drive, there are two alternatives:

- Use an ACS-AP-I/S/W assistant control panel as a converter. Use a USB type A – type Mini-B cable. The maximum permitted length of the cable is 3 m (9.8 ft).
- Use a USB to RJ45 converter. You can order it from ABB (BCBL-01, 3AXD50000032449). Connect the cable to the Panel and PC tool port (RJ45).

For information on the Drive composer PC tool, refer to *Drive composer PC tool user's manual* (3AUA0000094606 [English]).

You can use the CCA-01 cold configuration tool to download software and change drive parameters without connecting the drive to the input power. The CCA-01 does not operate if the drive is powered.



7

Installation checklist

Contents of this chapter

This chapter contains a checklist for the mechanical and electrical installation of the drive.

Checklist

Examine the mechanical and electrical installation of the drive before start-up. Go through the checklist together with another person.



WARNING!

Obey the safety instructions of the drive. If you ignore them, injury or death, or damage to the equipment can occur. If you are not a qualified electrical professional, do not do installation, commissioning or maintenance work.



WARNING!

Stop the drive and do the steps in section [Electrical safety precautions](#) (page 16) before you start the work.

Make sure that ...	<input checked="" type="checkbox"/>
The ambient operating conditions meet the drive ambient conditions specification and enclosure rating (IP code).	<input type="checkbox"/>
The supply voltage matches the nominal input voltage of the drive. See the type designation label.	<input type="checkbox"/>

78 Installation checklist

Make sure that ...	<input checked="" type="checkbox"/>
The insulation resistance of the input power cable, motor cable and motor is measured according to local regulations and the manuals of the drive.	<input type="checkbox"/>
The drive is attached securely on an even, vertical and non-flammable wall.	<input type="checkbox"/>
The cooling air flows freely in and out of the drive.	<input type="checkbox"/>
<u>If the drive is connected to a network other than a symmetrically grounded TN-S system:</u> You have done all the required modifications (for example, you may need to disconnect the EMC filter or ground-to-phase varistor). See the electrical installation instructions.	<input type="checkbox"/>
Appropriate AC fuses and main disconnecting device are installed.	<input type="checkbox"/>
There is an adequately sized protective earth (ground) conductor(s) between the drive and the switchboard, the conductor is connected to correct terminal, and the terminal is tightened to the correct torque. Grounding has also been measured according to the regulations.	<input type="checkbox"/>
The input power cable is connected to the correct terminals, the phase order is correct, and the terminals are tightened to the correct torque.	<input type="checkbox"/>
There is an adequately sized protective earth (ground) conductor between the motor and the drive. The conductor is connected to the correct terminal, and the terminal is tightened to the correct torque. Grounding has also been measured according to the regulations.	<input type="checkbox"/>
The motor cable is connected to the correct terminals, the phase order is correct, and the terminals are tightened to the correct torque.	<input type="checkbox"/>
The motor cable is routed away from other cables.	<input type="checkbox"/>
No power factor compensation capacitors are connected to the motor cable.	<input type="checkbox"/>
The control cables are connected to the correct terminals, and the terminals are tightened to the correct torque.	<input type="checkbox"/>
<u>If a drive bypass connection will be used:</u> The Direct On Line contactor of the motor and the drive output contactor are either mechanically and/or electrically interlocked, that is, they cannot be closed at the same time. A thermal overload device must be used for protection when bypassing the drive. Refer to local codes and regulations.	<input type="checkbox"/>
There are no tools, foreign objects or dust from drilling inside the drive.	<input type="checkbox"/>
The area in front of the drive is clean: the drive cooling fan cannot draw any dust or dirt inside.	<input type="checkbox"/>
Drive covers and cover of the motor connection box are in place.	<input type="checkbox"/>
The motor and the driven equipment are ready for power-up.	<input type="checkbox"/>



Maintenance

Contents of this chapter

The chapter contains the preventive maintenance instructions.

Maintenance intervals

The tables below show the maintenance tasks which can be done by the end user. The complete maintenance schedule is available on the Internet (<https://new.abb.com/drives/services/maintenance/preventive-maintenance>). For more information, consult your local ABB Service representative (www.abb.com/searchchannels).

■ Description of symbols

Action	Description
I	Inspection (visual inspection and maintenance action if needed)
P	Performance of on/off-site work (commissioning, tests, measurements or other work)
R	Replacement

■ **Recommended maintenance intervals after start-up**

Recommended annual actions by the user	
Connections and environment	
Quality of the supply voltage	P
Spare parts	
Spare parts	I
Reforming DC circuit capacitors of spare modules	P
Inspections	
Tightness of terminals	I
Dustiness, corrosion and temperature	I
Cleaning the heatsink	P

Maintenance task/object	Years from start-up						
	3	6	9	12	15	18	21
Cooling fans							
Main cooling fan (frames R1...R4)		R		R		R	

Note:

- Maintenance and component replacement intervals are based on the assumption that the equipment is operated within the specified ratings and ambient conditions. ABB recommends annual drive inspections to ensure the highest reliability and optimum performance.
- Long term operation near the specified maximum ratings or ambient conditions may require shorter maintenance intervals for certain components. Consult your local ABB Service representative for additional maintenance recommendations.

Cleaning the heatsink

The drive module heatsink fins pick up dust from the cooling air. The drive runs into overtemperature warnings and faults if the heatsink is not clean. When necessary, clean the heatsink as follows.

 **WARNING!** Use the required personal protective equipment. Wear protective gloves and long sleeves. Some parts have sharp edges.

**WARNING!**

Use a vacuum cleaner with antistatic hose and nozzle, and wear a grounding wristband. Using a normal vacuum cleaner creates static discharges which can damage circuit boards.

1. Stop the drive and do the steps in section [Electrical safety precautions](#) (page 16) before you start the work.
2. Remove the module cooling fan(s). See the separate instructions.
3. Blow dry, clean and oil-free compressed air from bottom to top and simultaneously use a vacuum cleaner at the air outlet to trap the dust. If there is a risk of dust entering adjoining equipment, do the cleaning in another room.
4. Reinstall the cooling fan.

Replacing the cooling fans

These instructions are applicable only to frame sizes R1,R2,R3 and R4. Frame R0 units do not have a cooling fan.

Parameter *05.04 Fan on-time counter* shows the running time of the cooling fan. After you replace the fan, reset the fan counter. Refer to the firmware manual.

You can get replacement fans from ABB. Use only ABB specified spare parts.

■ To replace the cooling fan for frame size R1

**WARNING!**

Obey the safety instructions of the drive. If you ignore them, injury or death, or damage to the equipment can occur. If you are not a qualified electrical professional, do not do installation, commissioning or maintenance work.

1. Stop the drive and do the steps in section [Electrical safety precautions](#) (page 16) before you start the work.
 2. Press the two clips by fingers to open the fan cover.
-

3. Carefully lift the fan cover out of the drive. Note that the fan cover holds the cooling fan.

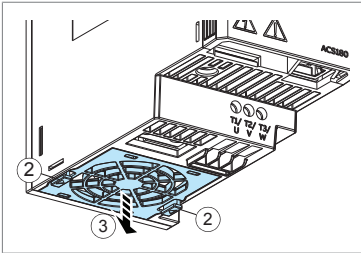

4. Disconnect the fan power cable.

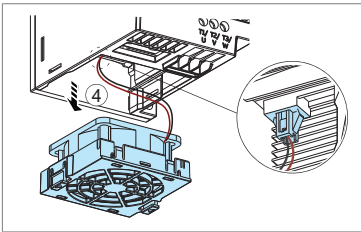

5. Free the fan clips and remove the fan from the fan cover.
6. Install the new fan into the fan cover. Make sure that the air flow is in the correct direction. The air flows in from the bottom of the drive and out from the top of the drive. As shown in the following figure, the side with the fan power cable is aligned to the double bars sign on the fan cover.

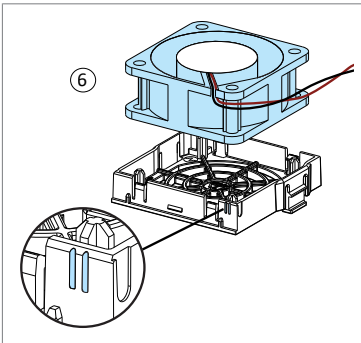

7. Connect the fan power cable.

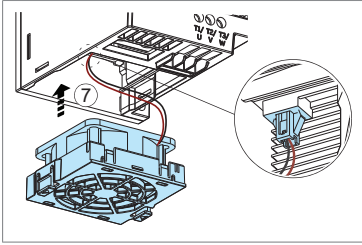

8. Carefully put the fan cover into position in the drive. Make sure that the fan power cable is routed correctly. Push the cover to lock into position.

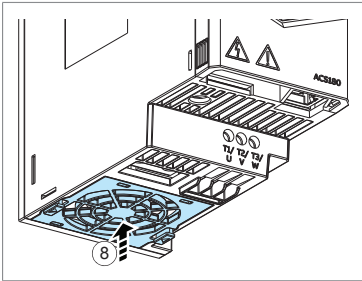

■ To replace the cooling fan for frame size R2



WARNING!

Obey the safety instructions of the drive. If you ignore them, injury or death, or damage to the equipment can occur. If you are not a qualified electrical professional, do not do installation, commissioning or maintenance work.

84 Maintenance

1. Stop the drive and do the steps in section [Electrical safety precautions](#) (page 16) before you start the work.
2. Press the two clips by fingers to open the fan cover.
3. Carefully lift the fan cover out of the drive. Note that the fan cover holds the cooling fan.

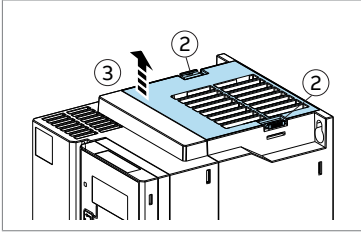

4. Disconnect the fan power cable.

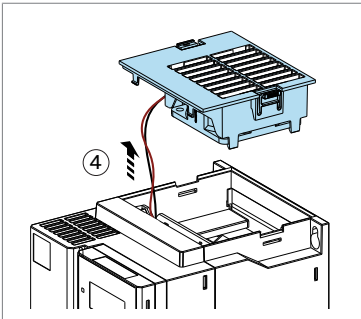

5. Free the fan clips and remove the fan from the fan cover.
6. Install the new fan into the fan cover. Make sure that the air flow is in the correct direction. The air flows in from the bottom of the drive and out from the top of the drive.

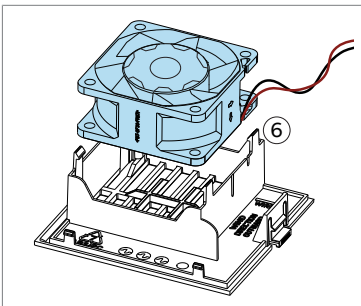

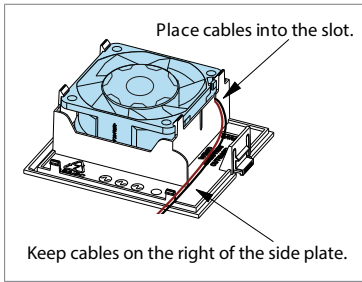

7. Connect the fan power cable.

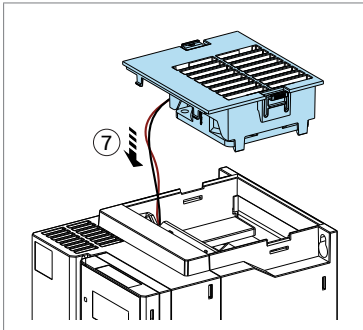

8. Carefully put the fan cover into position in the drive. Make sure that the fan power cable is routed correctly. Push the cover to lock into position.

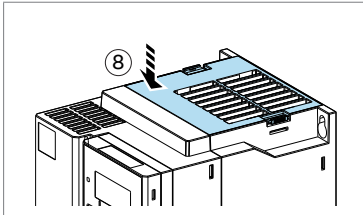

■ To replace the cooling fan for frame size R3



WARNING!

Obey the safety instructions of the drive. If you ignore them, injury or death, or damage to the equipment can occur. If you are not a qualified electrical professional, do not do installation, commissioning or maintenance work.

1. Stop the drive and do the steps in section [Electrical safety precautions](#) (page 16) before you start the work.
2. Use a suitable flat screwdriver to open the fan cover.

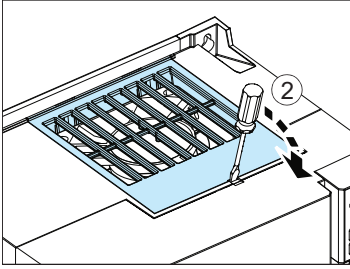

3. Carefully lift the fan cover out of the drive. The fan cover holds the cooling fan.

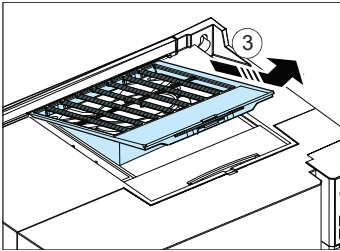

4. Disconnect the fan power cable.

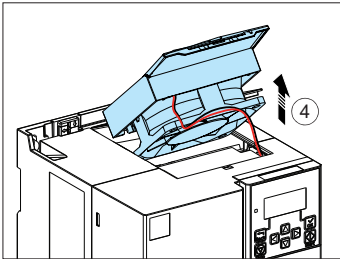

5. Install the new fan into the fan cover. Make sure that the air flow is in the correct direction. The air flows in from the bottom of the drive and out from the top of the drive.

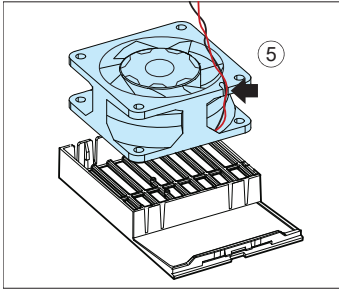

6. Connect the fan power cable.

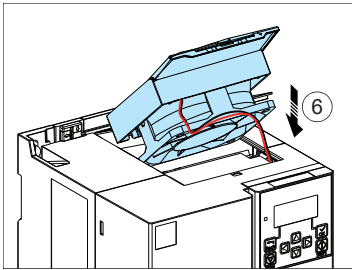

7. Carefully put the fan cover into position in the drive. Make sure that the fan power cable is routed correctly.
8. Push the cover to lock into position.

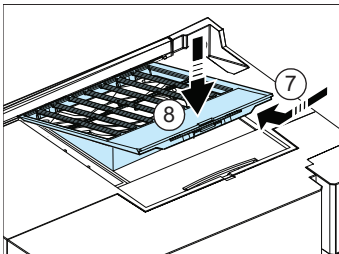

■ To replace the cooling fan for frame size R4



WARNING!

Obey the safety instructions of the drive. If you ignore them, injury or death, or damage to the equipment can occur. If you are not a qualified electrical professional, do not do installation, commissioning or maintenance work.

1. Stop the drive and do the steps in section [Electrical safety precautions](#) (page 16) before you start the work.
2. Use a suitable flat screwdriver to open the fan cover.

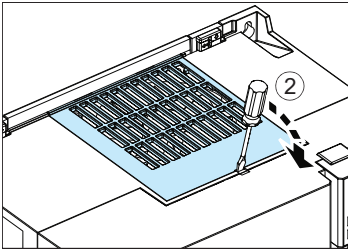

3. Lift out the fan cover and set it aside.

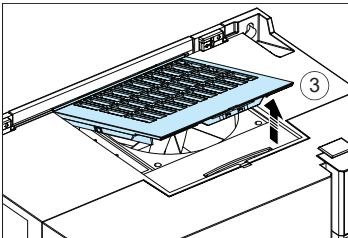

4. Lift and pull the fan from its base.
5. Disconnect the fan power cable from the extension cable connector.

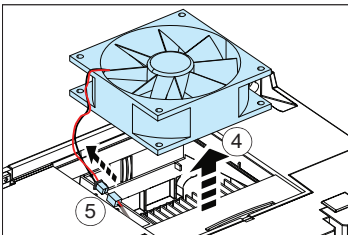

6. Replace the fan. Make sure that the air flow is in the correct direction. The air flows in from the bottom of the drive and out from the top of the drive.
7. Connect the fan power cable.

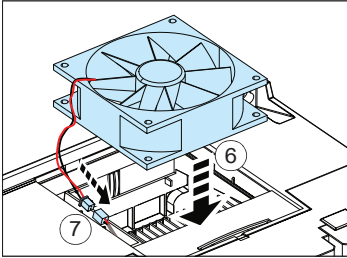

8. Place the fan cover back on the frame.
9. Push the cover to lock into position.

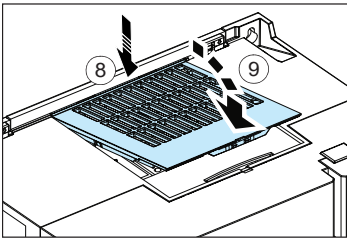

Capacitors

The DC link of the drive contains several electrolytic capacitors. Operating time, load, and surrounding air temperature have an effect on the life of the capacitors. Capacitor life can be extended by decreasing the surrounding air temperature.

Capacitor failure is usually followed by damage to the unit and an input cable fuse failure, or a fault trip. If you think that any capacitors in the drive have failed, contact ABB.

■ Reforming the capacitors

The capacitors must be reformed if the drive has not been powered (either in storage or unused) for a year or more. The manufacturing date is on the type designation label. For information on reforming the capacitors, refer to [Capacitor reforming instructions \(3BFE64059629 \[English\]\)](#).

9

Technical data

Contents of this chapter

The chapter contains the technical specifications of the drive, such as ratings, sizes and technical requirements as well as provisions for fulfilling the requirements for CE, UL and other approval marks.

Ratings

■ IEC ratings

ACS180-04...	Input current	Input with choke	Output ratings							Frame size
			Max. current	Nominal use		Light-duty use		Heavy-duty use		
			I_{max}	I_n	P_n	I_{Ld}	P_{Ld}	I_{Hd}	P_{Hd}	
A	A	A	A	kW	A	kW	A	kW		
1-phase $U_n = 200 \dots 240 \text{ V}$										
-02A4-1	5	3.3	3.2	2.4	0.37	2.3	0.37	1.8	0.25	R0
-03A7-1	6.9	4.8	4.3	3.7	0.55	3.5	0.55	2.4	0.37	R0
-04A8-1	9	6.2	6.7	4.8	0.75	4.6	0.75	3.7	0.55	R0
-06A9-1	12.6	9.2	8.1	6.9	1.1	6.6	1.1	4.5	0.75	R1
-07A8-1	17.3	12	11.9	7.8	1.5	7.4	1.5	6.6	1.1	R1
-09A8-1	21.8	17	13.3	9.8	2.2	9.3	2.2	7.4	1.5	R1
-12A2-1	23.9	21.1	17.6	12.2	3	11.6	3	9.8	2.2	R2
3-phase $U_n = 200 \dots 240 \text{ V}$										
-02A4-2	3.6	2.4	3.2	2.4	0.37	2.3	0.37	1.8	0.25	R0
-03A7-2	5.6	3.7	4.3	3.7	0.55	3.5	0.55	2.4	0.37	R0

ACS180-04...	Input current	Input with choke	Output ratings								Frame size
			Max. current	Nominal use		Light-duty use		Heavy-duty use			
				I_{max}	I_n	P_n	I_{Ld}	P_{Ld}	I_{Hd}	P_{Hd}	
A	A	A	A	kW	A	kW	A	kW			
-04A8-2	7.2	4.8	6.7	4.8	0.75	4.6	0.75	3.7	0.55	R0	
-06A9-2	10.4	6.9	8.1	6.9	1.1	6.6	1.1	4.5	0.75	R1	
-07A8-2	11.7	7.8	11.9	7.8	1.5	7.4	1.5	6.6	1.1	R1	
-09A8-2	14.7	9.8	13.3	9.8	2.2	9.3	2.2	7.4	1.5	R1	
-15A6-2	19.2	15.6	19.3	15.6	3	14.6	3	10.7	2.2	R2	
-17A5-2	23.6	17.5	22	17.5	4	16.7	4	12.2	3	R2	
-25A0-2	27.2	25	31.5	25	5.5	24.2	5.5	17.5	4	R3	
-033A-2	35	32	45	32	7.5	30.8	7.5	25	5.5	R3	
-048A-2	48	48	57.6	48	11	46.2	11	32	7.5	R4	
-055A-2	60	55	83.2	55	11	50.2	11	46.2	11	R4	
3-phase $U_n = 380 \dots 415 \text{ V}$											
-01A8-4	2.8	1.5	2.2	1.8	0.55	1.7	0.55	1.2	0.37	R0	
-02A6-4	3.6	1.9	3.2	2.6	0.75	2.5	0.75	1.8	0.55	R0	
-03A3-4	4.6	2.5	4.3	3.3	1.1	3.1	1.1	2.4	0.75	R0	
-04A0-4	6.3	3.3	5.9	4	1.5	3.8	1.5	3.3	1.1	R1	
-05A6-4	9.1	4.6	7.2	5.6	2.2	5.3	2.2	4	1.5	R1	
-07A2-4	12	5.9	10.1	7.2	3	6.8	3	5.6	2.2	R1	
-09A4-4	13	7.9	13	9.4	4	8.9	4	7.2	3	R1	
-12A6-4	17.4	12.6	16.9	12.6	5.5	12	5.5	9.4	4	R2	
-17A0-4	25.2	17	22.7	17	7.5	16.2	7.5	12.6	5.5	R2	
-25A0-4	31.8	25	30.6	25	11	23.8	11	17	7.5	R3	
-033A-4	40.9	32	45	32	15	30.5	15	25	11	R3	
-038A-4	49	38	57.6	38	18.5	36	18.5	32	15	R4	
-045A-4	55.7	45	68.4	45	22	42	22	38	18.5	R4	
-050A-4	55.7	50	81	50	22	48	22	45	22	R4	

■ **UL (NEC) ratings**

ACS180-04...	Input current	Input with choke	Output ratings						Frame size
			Max. current	Light-duty use		Heavy-duty use			
				I_{max}	I_{Ld}	P_{Ld}	I_{Hd}	P_{Hd}	
A	A	A	A	hp	A	hp			
1-phase $U_n = 200 \dots 240 \text{ V}$									
-02A4-1	5	3.3	3.2	2.3	0.5	1.8	0.33	R0	
-03A7-1	6.9	4.8	4.3	3.5	0.75	2.4	0.5	R0	

ACS180-04...	Input current	Input with choke	Output ratings					Frame size
			Max. current	Light-duty use		Heavy-duty use		
			I_{max}	I_{Ld}	P_{Ld}	I_{Hd}	P_{Hd}	
			A	A	hp	A	hp	
-04A8-1	9	6.2	6.7	4.6	1	3.7	0.75	R0
-06A9-1	12.6	9.2	8.1	6.6	1.5	4.5	1	R1
-07A8-1	17.3	12	11.9	7.4	2	6.6	1.5	R1
-09A8-1	21.8	17	13.3	9.3	3	7.4	2	R1
-12A2-1	23.9	21.1	17.6	11.6	3	9.8	3	R2
3-phase $U_n = 200 \dots 240$ V								
-02A4-2	3.6	2.4	3.2	2.3	0.5	1.8	0.33	R0
-03A7-2	5.6	3.7	4.3	3.5	0.75	2.4	0.5	R0
-04A8-2	7.2	4.8	6.7	4.6	1	3.7	0.75	R0
-06A9-2	10.4	6.9	8.1	6.6	1.5	4.5	1	R1
-07A8-2	11.7	7.8	11.9	7.4	2	6.6	1.5	R1
-09A8-2	14.7	9.8	13.3	9.3	3	7.4	2	R1
-15A6-2	19.2	15.6	19.3	14.6	3	10.7	3	R2
-17A5-2	23.6	17.5	22	16.7	5	12.2	3	R2
-25A0-2	27.2	25	31.5	24.2	7.5	17.5	5	R3
-033A-2	35	32	45	30.8	10	25	7.5	R3
-048A-2	48	48	57.6	46.2	15	32	10	R4
-055A-2	60	55	83.2	50.2	15	46.2	15	R4
3-phase $U_n = 440 \dots 480$ V								
-01A8-4	1.9	1.3	2.2	1.6	0.75	1.1	0.5	R0
-02A6-4	2.4	1.6	3.2	2.1	1	1.6	0.75	R0
-03A3-4	3.5	2.1	4.3	3	1.5	2.1	1	R0
-04A0-4	4.6	2.8	5.9	3.5	2	3	1.5	R1
-05A6-4	6.9	3.8	7.2	4.7	3	3.4	2	R1
-07A2-4	9.2	5	10.1	6	3	4.8	3	R1
-09A4-4	10.3	6.7	13	7.6	5	6.3	3	R1
-12A6-4	14.8	11	16.9	11	7.5	7.6	5	R2
-17A0-4	20.3	14	22.7	14	10	11	7.5	R2
-25A0-4	26.6	21	30.6	21	15	14	10	R3
-033A-4	33.9	27	45	27	20	21	15	R3
-038A-4	41.3	34	57.6	34	25	27	20	R4
-045A-4	46.9	40	68.4	40	30	34	25	R4
-050A-4	46.9	42	81	42	30	40	30	R4

■ **Definitions**

The heavy duty ratings are valid at a surrounding air temperature of 50 °C (122 °F) and the light duty ratings are valid at a surrounding air temperature of 40 °C (104 °F) with the default drive switching frequency of 4 kHz (parameter 97.01), and with an installation altitude below 1000 m (3281 ft).

U_n	Nominal supply voltage. For input voltage range U1, refer to Electrical power network specification (page 115) .
I_1	Nominal input current with typical motor power P_n . Continuous rms input current, for dimensioning cables and fuses.
I_{max}	Maximum output current. Available for two seconds at start.
I_n	Nominal output current. Maximum continuous rms output current allowed (no overload).
P_n	Typical motor power in nominal use (no overloading). The kilowatt ratings are applicable to most IEC 4-pole (400 V, 50 Hz) motors. The horsepower ratings are applicable to most NEMA 4-pole (460V 60Hz) motors
I_{Ld}	Maximum output current with 110% overload, allowed for one minute every ten minutes.
P_{Ld}	Typical motor power in light-duty use (110% overload).
I_{Hd}	Maximum output current with 150% overload, allowed for one minute every ten minutes.
P_{Hd}	Typical motor power in heavy-duty use (150% overload)

■ **Sizing**

ABB recommends the DriveSize tool for selecting the drive, motor and gear combination (<https://new.abb.com/drives/software-tools/drivesize>). You can also use the ratings tables.

The minimum recommended nominal current of the motor is 40% of the drive nominal output current (I_n). If the motor has a lower nominal current rating than this, the drive cannot accurately measure the motor current.

Output derating

The load capacity (I_n, I_{Ld}, I_{Hd}) decreases in some situations. In such situations, where full motor power is required, oversize the drive so that the total derated output current is sufficient for the motor to reach the full power.

In an environment where more than one type of derating is necessary (for example, high altitude and high temperature), the effects of derating are cumulative.

Note:

- I_{\max} is not derated.
- The motor can also have a derating on it.
- You can also use the DriveSize tool for derating.

See Surrounding air temperature derating (page 97), Altitude derating (page 99) and Switching frequency derating (page 99) for the derating values.

Example 1, IEC: How to calculate the derated current

The drive type is ACS180-04x-17A0-4, which has a nominal output current (I_N) of 17 A at 400 V. Calculate the derated output current at 4 kHz switching frequency, at 1500 m altitude and at 55 °C surrounding air temperature.

Switching frequency derating: Derating is not necessary at 4 kHz.

Altitude derating: The derating factor for 1500 m is

$$1 - \frac{1500 \text{ m} - 1000 \text{ m}}{10000 \text{ m}} = 0.95$$

Surrounding air temperature derating: According to the temperature derating table, the derating factor of 17A0-4 drive's nominal output current at 55 °C surrounding air temperature is 0.775.

Multiply the nominal drive output current by all the applicable derating factors. In this example, the derated output current becomes

$$I_N = 17 \text{ A} \cdot 0.95 \cdot 0.775 = 12.52 \text{ A}$$

Example 1, UL (NEC): How to calculate the derated current

The drive type is ACS180-04x-17A0-4, which has light-duty output current (I_{Ld}) of 14 A at 480 V. Calculate the derated output current at 4 kHz switching frequency, at 6000 ft altitude and at 131 °F surrounding air temperature.

Switching frequency derating: Derating is not necessary at 4 kHz.

Altitude derating: The derating factor for 6000 ft is

$$1 - \frac{6000 \text{ ft} - 3281 \text{ ft}}{32810 \text{ ft}} = 0.917$$

Surrounding air temperature derating: According to the temperature derating table, the derating factor of 17A0-4 drive's light-duty output current at 131 °F surrounding air temperature is 0.775.

Multiply the drive output current by all the applicable derating factors. In this example, the derated output current becomes

$$I_{Ld} = 14 \text{ A} \cdot 0.917 \cdot 0.775 = 9.95 \text{ A}$$

Example 2, IEC: How to calculate the required drive

The application requires a nominal motor current of 6.0 A at a switching frequency of 8 kHz. The supply voltage is 400 V, the altitude is 1800 m and the surrounding air temperature is 35 °C.

Altitude derating: The derating factor for 1800 m is

$$1 - \frac{1800\text{ m} - 1000\text{ m}}{10000\text{ m}} = 0.92$$

Surrounding air temperature derating: Derating is not necessary at 35 °C surrounding air temperature.

To see if the derated output current of a drive is sufficient for the application, multiply the nominal output current (I_N) by all the applicable derating factors. For example, drive type ACS180-04x-12A6-4 has a nominal output current of 12.6 A at 400 V. The switching frequency derating factor for this drive type is 0.68 at 8 kHz. Calculate the derated drive output current:

$$I_N = 12.6\text{ A} \cdot 0.68 \cdot 0.92 = 7.88\text{ A}$$

In this example, the derated output current is sufficient, because it is higher than the required current.

Example 2, UL (NEC): How to calculate the required drive

The application requires a maximum of 12.0 A of motor current with a 10% overload for one minute every ten minutes (I_{Ld}) at a switching frequency of 8 kHz. The supply voltage is 480 V, the altitude is 5500 ft and the surrounding air temperature is 95 °F.

Altitude derating: The derating factor for 5500 ft is

$$1 - \frac{5500\text{ ft} - 3281\text{ ft}}{32810\text{ ft}} = 0.932$$

Surrounding air temperature derating: Derating is not necessary at 95 °F surrounding air temperature.

To see if the derated output current of a drive is sufficient for the application, multiply the drive output current for light-duty use (I_{Ld}) by all the applicable derating factors. For example, drive type ACS180-04x-25A0-4 has an output current of 21 A at 480 V. The switching frequency derating for this drive type is 0.7 at 8 kHz. Calculate the derated drive output current:

$$I_{Ld} = 21\text{ A} \cdot 0.7 \cdot 0.932 = 13.7\text{ A}$$

In this example, the derated output current is sufficient, because it is higher than the required current.

■ Surrounding air temperature derating

Frame		Install side-by-side	Installation with 50mm space between																																																						
R0	Derating factor for I_{Hd} (Heavy duty rating, 150% overloadability)	<table border="1"> <caption>Derating factor for I_{Hd} (side-by-side)</caption> <tr><th>Ambient temperature (°C)</th><td>-10</td><td>0</td><td>10</td><td>20</td><td>30</td><td>40</td><td>50</td><td>60</td></tr> <tr><th>Ambient temperature (°F)</th><td>14</td><td>32</td><td>50</td><td>68</td><td>86</td><td>104</td><td>122</td><td>140</td></tr> <tr><th>Derating factor (%)</th><td>100</td><td>100</td><td>100</td><td>100</td><td>100</td><td>100</td><td>80</td><td>0</td></tr> </table>	Ambient temperature (°C)	-10	0	10	20	30	40	50	60	Ambient temperature (°F)	14	32	50	68	86	104	122	140	Derating factor (%)	100	100	100	100	100	100	80	0	<table border="1"> <caption>Derating factor for I_{Hd} (50mm space)</caption> <tr><th>Ambient temperature (°C)</th><td>-10</td><td>0</td><td>10</td><td>20</td><td>30</td><td>40</td><td>50</td><td>60</td></tr> <tr><th>Ambient temperature (°F)</th><td>14</td><td>32</td><td>50</td><td>68</td><td>86</td><td>104</td><td>122</td><td>140</td></tr> <tr><th>Derating factor (%)</th><td>100</td><td>100</td><td>100</td><td>100</td><td>100</td><td>100</td><td>0</td><td>0</td></tr> </table>	Ambient temperature (°C)	-10	0	10	20	30	40	50	60	Ambient temperature (°F)	14	32	50	68	86	104	122	140	Derating factor (%)	100	100	100	100	100	100	0	0
	Ambient temperature (°C)	-10	0	10	20	30	40	50	60																																																
Ambient temperature (°F)	14	32	50	68	86	104	122	140																																																	
Derating factor (%)	100	100	100	100	100	100	80	0																																																	
Ambient temperature (°C)	-10	0	10	20	30	40	50	60																																																	
Ambient temperature (°F)	14	32	50	68	86	104	122	140																																																	
Derating factor (%)	100	100	100	100	100	100	0	0																																																	
Derating factor for I_N and I_{Ld} (Normal and light duty rating, no or 110% overloadability)	<table border="1"> <caption>Derating factor for I_N and I_{Ld} (side-by-side)</caption> <tr><th>Ambient temperature (°C)</th><td>-10</td><td>0</td><td>10</td><td>20</td><td>30</td><td>40</td><td>50</td><td>60</td></tr> <tr><th>Ambient temperature (°F)</th><td>14</td><td>32</td><td>50</td><td>68</td><td>86</td><td>104</td><td>122</td><td>140</td></tr> <tr><th>Derating factor (%)</th><td>100</td><td>100</td><td>100</td><td>100</td><td>100</td><td>100</td><td>75</td><td>0</td></tr> </table>	Ambient temperature (°C)	-10	0	10	20	30	40	50	60	Ambient temperature (°F)	14	32	50	68	86	104	122	140	Derating factor (%)	100	100	100	100	100	100	75	0	<table border="1"> <caption>Derating factor for I_N and I_{Ld} (50mm space)</caption> <tr><th>Ambient temperature (°C)</th><td>-10</td><td>0</td><td>10</td><td>20</td><td>30</td><td>40</td><td>50</td><td>60</td></tr> <tr><th>Ambient temperature (°F)</th><td>14</td><td>32</td><td>50</td><td>68</td><td>86</td><td>104</td><td>122</td><td>140</td></tr> <tr><th>Derating factor (%)</th><td>100</td><td>100</td><td>100</td><td>100</td><td>100</td><td>100</td><td>80</td><td>0</td></tr> </table>	Ambient temperature (°C)	-10	0	10	20	30	40	50	60	Ambient temperature (°F)	14	32	50	68	86	104	122	140	Derating factor (%)	100	100	100	100	100	100	80	0	
Ambient temperature (°C)	-10	0	10	20	30	40	50	60																																																	
Ambient temperature (°F)	14	32	50	68	86	104	122	140																																																	
Derating factor (%)	100	100	100	100	100	100	75	0																																																	
Ambient temperature (°C)	-10	0	10	20	30	40	50	60																																																	
Ambient temperature (°F)	14	32	50	68	86	104	122	140																																																	
Derating factor (%)	100	100	100	100	100	100	80	0																																																	
R1	Derating factor for I_{Hd}	<table border="1"> <caption>Derating factor for I_{Hd} (R1)</caption> <tr><th>Ambient temperature (°C)</th><td>-10</td><td>0</td><td>10</td><td>20</td><td>30</td><td>40</td><td>50</td><td>60</td><td>70</td></tr> <tr><th>Ambient temperature (°F)</th><td>14</td><td>32</td><td>50</td><td>68</td><td>86</td><td>104</td><td>122</td><td>140</td><td>158</td></tr> <tr><th>Derating factor (%)</th><td>100</td><td>100</td><td>100</td><td>100</td><td>100</td><td>100</td><td>100</td><td>75</td><td>0</td></tr> </table>		Ambient temperature (°C)	-10	0	10	20	30	40	50	60	70	Ambient temperature (°F)	14	32	50	68	86	104	122	140	158	Derating factor (%)	100	100	100	100	100	100	100	75	0																								
	Ambient temperature (°C)	-10	0	10	20	30	40	50	60	70																																															
Ambient temperature (°F)	14	32	50	68	86	104	122	140	158																																																
Derating factor (%)	100	100	100	100	100	100	100	75	0																																																
Derating factor for I_N and I_{Ld}	<table border="1"> <caption>Derating factor for I_N and I_{Ld} (R1)</caption> <tr><th>Ambient temperature (°C)</th><td>-10</td><td>0</td><td>10</td><td>20</td><td>30</td><td>40</td><td>50</td><td>60</td><td>70</td></tr> <tr><th>Ambient temperature (°F)</th><td>14</td><td>32</td><td>50</td><td>68</td><td>86</td><td>104</td><td>122</td><td>140</td><td>158</td></tr> <tr><th>Derating factor (%)</th><td>100</td><td>100</td><td>100</td><td>100</td><td>100</td><td>100</td><td>100</td><td>65</td><td>0</td></tr> </table>		Ambient temperature (°C)	-10	0	10	20	30	40	50	60	70	Ambient temperature (°F)	14	32	50	68	86	104	122	140	158	Derating factor (%)	100	100	100	100	100	100	100	65	0																									
Ambient temperature (°C)	-10	0	10	20	30	40	50	60	70																																																
Ambient temperature (°F)	14	32	50	68	86	104	122	140	158																																																
Derating factor (%)	100	100	100	100	100	100	100	65	0																																																

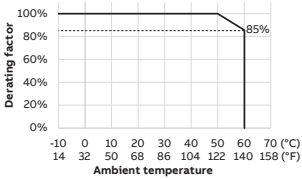
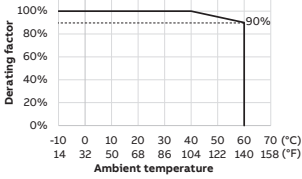
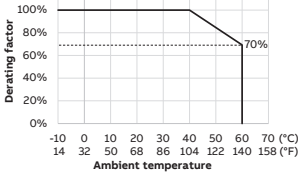
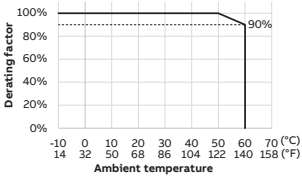
Frame		Install side-by-side	Installation with 50mm space between
R2	Derating factor for I_{Hd}		 <p>A line graph showing the derating factor for I_{Hd} as a function of ambient temperature for side-by-side installation. The y-axis is labeled 'Derating factor' and ranges from 0% to 100% in 20% increments. The x-axis is labeled 'Ambient temperature' and has two scales: Celsius (-10, 0, 10, 20, 30, 40, 50, 60, 70) and Fahrenheit (14, 32, 50, 68, 86, 104, 122, 140, 158). The curve starts at 100% for temperatures from -10°C to 50°C. Between 50°C and 60°C, the derating factor decreases linearly to 85%. At 60°C, the derating factor drops sharply to 0% at 70°C.</p>
	Derating factor for I_N and I_{Ld} on ACS180-...-1/2		 <p>A line graph showing the derating factor for I_N and I_{Ld} on ACS180-...-1/2 as a function of ambient temperature for side-by-side installation. The y-axis is labeled 'Derating factor' and ranges from 0% to 100% in 20% increments. The x-axis is labeled 'Ambient temperature' and has two scales: Celsius (-10, 0, 10, 20, 30, 40, 50, 60, 70) and Fahrenheit (14, 32, 50, 68, 86, 104, 122, 140, 158). The curve starts at 100% for temperatures from -10°C to 40°C. Between 40°C and 60°C, the derating factor decreases linearly to 90%. At 60°C, the derating factor drops sharply to 0% at 70°C.</p>
	Derating factor for I_N and I_{Ld} on ACS180-...-4		 <p>A line graph showing the derating factor for I_N and I_{Ld} on ACS180-...-4 as a function of ambient temperature for side-by-side installation. The y-axis is labeled 'Derating factor' and ranges from 0% to 100% in 20% increments. The x-axis is labeled 'Ambient temperature' and has two scales: Celsius (-10, 0, 10, 20, 30, 40, 50, 60, 70) and Fahrenheit (14, 32, 50, 68, 86, 104, 122, 140, 158). The curve starts at 100% for temperatures from -10°C to 40°C. Between 40°C and 60°C, the derating factor decreases linearly to 70%. At 60°C, the derating factor drops sharply to 0% at 70°C.</p>
R3	Derating factor for I_N , I_{Ld} and I_{Hd}		 <p>A line graph showing the derating factor for I_N, I_{Ld} and I_{Hd} as a function of ambient temperature for installation with 50mm space between. The y-axis is labeled 'Derating factor' and ranges from 0% to 100% in 20% increments. The x-axis is labeled 'Ambient temperature' and has two scales: Celsius (-10, 0, 10, 20, 30, 40, 50, 60, 70) and Fahrenheit (14, 32, 50, 68, 86, 104, 122, 140, 158). The curve starts at 100% for temperatures from -10°C to 50°C. Between 50°C and 60°C, the derating factor decreases linearly to 90%. At 60°C, the derating factor drops sharply to 0% at 70°C.</p>

Frame		Install side-by-side	Installation with 50mm space between
R4	Derating factor for I_N , I_{Ld} and I_{Hd} on ACS180-04x-048A-2, 045A-4		
	Derating factor for I_N , I_{Ld} and I_{Hd} on ACS180-04x-055A-2, 038A-4, 050A-4		

■ **Altitude derating**

1000...2000 m above sea level, the derating is 1% for every 100 m (330 ft).

To calculate the output current, multiply the current in the rating table with the derating factor k , which for x meters ($1000\text{ m} \leq x \leq 2000\text{ m}$) is:

$$k = 1 - \frac{x - 1000\text{ m}}{10000\text{ m}}$$

■ **Switching frequency derating**

Type ACS180-04...	Current multiplier with different switching frequencies			
	2 kHz	4 kHz	8 kHz	12 kHz
1-phase $U_n = 200 \dots 240\text{ V}$				
-02A4-1	1	1	0.8	0.7
-03A7-1	1	1	0.8	0.7
-04A8-1	1	1	0.8	0.7
-06A9-1	1	1	0.8	0.7
-07A8-1	1	1	0.8	0.7
-09A8-1	1	1	0.8	0.7
-12A2-1	1	1	0.8	0.7
3-phase $U_n = 200 \dots 240\text{ V}$				
-02A4-2	1	1	0.8	0.7

100 Technical data

Type ACS180-04...	Current multiplier with different switching frequencies			
	2 kHz	4 kHz	8 kHz	12 kHz
-03A7-2	1	1	0.8	0.7
-04A8-2	1	1	0.8	0.7
-06A9-2	1	1	0.8	0.7
-07A8-2	1	1	0.8	0.7
-09A8-2	1	1	0.8	0.7
-15A6-2	1	1	0.8	0.7
-17A5-2	1	1	0.8	0.7
-25A0-2	1	1	0.7	0.5
-033A-2	1	1	0.7	0.5
-048A-2	1	1	0.7	0.5
-055A-2	1	1	0.7	0.5
3-phase $U_n = 380 \dots 480 \text{ V}$				
-01A8-4	1	1	0.6	0.4
-02A6-4	1	1	0.6	0.4
-03A3-4	1	1	0.6	0.4
-04A0-4	1	1	0.6	0.4
-05A6-4	1	1	0.6	0.4
-07A2-4	1	1	0.6	0.4
-09A4-4	1	1	0.6	0.4
-12A6-4	1	1	0.6	0.4
-17A0-4	1	1	0.6	0.4
-25A0-4	1	1	0.7	0.5
-033A-4	1	1	0.7	0.5
-038A-4	1	1	0.7	0.5
-045A-4	1	1	0.7	0.5
-050A-4	1	1	0.7	0.5

Fuses

The tables list the fuses for protection against short-circuits in the input power cable or drive. The operating time depends on the supply network impedance, and the cross-sectional area and length of the supply cable.

Do not use fuses that have a higher current rating than specified in the table. You can use fuses from other manufacturers, if they meet the ratings, and if the melting curve of the fuse does not exceed the melting curve of the fuse mentioned in the table.

■ gG fuses (IEC)

Make sure that the operating time of the fuse is less than 0.5 seconds. Obey the local regulations.

ACS180-04...	Input current	Min. short-circuit current	Nominal current	I^2t	Voltage rating	ABB type
	A	A	A	A^2s	V	
1-phase $U_n = 200 \dots 240$ V						
-02A4-1	5	62	10	310	500	C10G10
-03A7-1	6.9	150	16	680	500	C10G16
-04A8-1	9	193	16	680	500	C10G16
-06A9-1	12.6	275	20	1200	500	C10G20
-07A8-1	17.3	372	25	2300	500	C10G25
-09A8-1	21.8	545	40	6300	500	C14G40
-12A2-1	23.9	641	40	6300	500	C14G40
3-phase $U_n = 200 \dots 240$ V						
-02A4-2	3.6	90	6	155	500	C10G6
-03A7-2	5.6	139	8	200	500	C10G8
-04A8-2	7.2	180	16	680	500	C10G16
-06A9-2	10.4	259	16	680	500	C10G16
-07A8-2	11.7	293	20	1200	500	C10G20
-09A8-2	14.7	368	25	2300	500	C10G25
-15A6-2	19.2	581	32	3000	500	C10G32
-17A5-2	23.6	656	32	6500	500	C10G32
-25A0-2	27.2	400	50	15500	500	OFAF000H50
-033A-2	35	504	63	20000	500	OFAF000H63
-048A-2	48	800	100	65000	500	OFAF000H100
-055A-2	60	800	100	65000	500	OFAF000H100
3-phase $U_n = 380 \dots 415$ V						
-01A8-4	2.8	47	4	110	500	C10G4
-02A6-4	3.6	59	6	155	500	C10G6

ACS180-04...	Input current	Min. short-circuit current	Nominal current	I^2t	Voltage rating	ABB type
	A	A	A	A ² s	V	
-03A3-4	4.6	87	10	310	500	C10G10
-04A0-4	6.3	116	10	310	500	C10G10
-05A6-4	9.1	174	16	680	500	C10G16
-07A2-4	12	230	20	1200	500	C10G20
-09A4-4	13	258	25	2300	500	C10G25
-12A6-4	17.4	440	32	3000	500	C10G32
-17A0-4	25.2	560	40	6500	500	C10G40
-25A0-4	31.8	400	50	15500	500	OFAF000H50
-033A-4	40.9	504	63	20000	500	OFAF000H63
-038A-4	49	640	80	36000	500	OFAF000H80
-045A-4	55.7	800	100	65000	500	OFAF000H100
-050A-4	55.7	800	100	65000	500	OFAF000H100

■ gR or aR -type fuses (IEC)

ACS180-04...	Input current	Min. short-circuit current	Nominal current	I^2t	Voltage rating	Busmann type
	A	A	A	A ² s	V	
1-phase $U_n = 200 \dots 240$ V						
-02A4-1	5	62	32	679	690	FWP-32G14F
-03A7-1	6.9	150	32	679	690	FWP-32G14F
-04A8-1	9	193	40	1331	690	FWP-40G14F
-06A9-1	12.6	275	50	2200	690	FWP-50G14F
-07A8-1	17.3	372	50	2200	690	FWP-50G14F
-09A8-1	21.8	545	50	2200	690	FWP-50G14F
-12A2-1	23.9	641	63	2575	690	FWP-63G22F
3-phase $U_n = 200 \dots 240$ V						
-02A4-2	3.6	90	25	333	690	FWP-25G14F
-03A7-2	5.6	139	32	679	690	FWP-32G14F
-04A8-2	7.2	180	32	679	690	FWP-32G14F
-06A9-2	10.4	259	50	2200	690	FWP-50G14F
-07A8-2	11.7	293	50	2200	690	FWP-50G14F
-09A8-2	14.7	368	50	2200	690	FWP-50G14F
-15A6-2	19.2	581	50	2200	690	FWP-50G14F
-17A5-2	23.6	656	50	2200	690	FWP-50G14F
-25A0-2	27.2	400	80	5448	690	FWP-80G22F
-033A-2	35	504	100	6650	690	FWP-100G22F

ACS180-04...	Input current	Min. short-circuit current	Nominal current	I^2t	Voltage rating	Bussmann type
	A	A	A	A^2s	V	
-048A-2	48	800	160	11700	700	FWP-150A
-055A-2	60	800	160	11700	700	FWP-150A
3-phase $U_n = 380 \dots 415 \text{ V}$						
-01A8-4	2.8	47	20	170	690	FWP-20G14F
-02A6-4	3.6	59	20	170	690	FWP-20G14F
-03A3-4	4.6	87	20	170	690	FWP-20G14F
-04A0-4	6.3	116	25	333	690	FWP-25G14F
-05A6-4	9.1	174	25	333	690	FWP-25G14F
-07A2-4	12	230	32	679	690	FWP-32G14F
-09A4-4	13	258	32	679	690	FWP-32G14F
-12A6-4	17.4	440	50	2200	690	FWP-50G14F
-17A0-4	25.2	560	50	2200	690	FWP-50G14F
-25A0-4	31.8	400	80	3600	690	FWP-80G22F
-033A-4	40.9	504	100	6650	690	FWP-100G22F
-038A-4	49	640	125	7300	700	FWP-125A
-045A-4	55.7	800	160	11700	700	FWP-150A
-050A-4	55.7	800	160	11700	700	FWP-150A

■ UL fuses (UL(NEC))

ACS180-04...	Input current	Min. short-circuit current	Nominal current	Voltage rating	Bussmann type	Type
	A	A	A	V		
1-phase $U_n = 200 \dots 240 \text{ V}$						
-02A4-1	5	62	6	300	JJN-6	UL class T
-03A7-1	6.9	150	10	300	JJN-10	UL class T
-04A8-1	9	193	15	300	JJN-15	UL class T
-06A9-1	12.6	275	20	300	JJN-20	UL class T
-07A8-1	17.3	372	25	300	JJN-25	UL class T
-09A8-1	21.8	545	35	300	JJN-35	UL class T
-12A2-1	23.9	641	35	300	JJN-35	UL class T
3-phase $U_n = 200 \dots 240 \text{ V}$						
-02A4-2	3.6	90	6	300	JJN-6	UL class T
-03A7-2	5.6	139	10	300	JJN-10	UL class T
-04A8-2	7.2	180	10	300	JJN-10	UL class T
-06A9-2	10.4	259	15	300	JJN-15	UL class T
-07A8-2	11.7	293	20	300	JJN-20	UL class T
-09A8-2	14.7	368	20	300	JJN-20	UL class T

ACS180-04...	Input current	Min. short-circuit current	Nominal current	Voltage rating	Bussmann type	Type
	A	A	A	V		
-15A6-2	19.2	581	30	300	JJN-30	UL class T
-17A5-2	23.6	656	35	300	JJN-35	UL class T
-25A0-2	27.2	400	40	300	JJN-40	UL class T
-033A-2	35	504	50	300	JJN-50	UL class T
-048A-2	48	800	70	300	JJN-70	UL class T
-055A-2	60	800	80	300	JJN-80	UL class T
3-phase $U_n = 440 \dots 480 \text{ V}$						
-01A8-4	2.8	47	6	600	JJS-6	UL class T
-02A6-4	3.6	59	6	600	JJS-6	UL class T
-03A3-4	4.6	87	10	600	JJS-10	UL class T
-04A0-4	6.3	116	10	600	JJS-10	UL class T
-05A6-4	9.1	174	20	600	JJS-20	UL class T
-07A2-4	12	230	20	600	JJS-20	UL class T
-09A4-4	13	258	25	600	JJS-25	UL class T
-12A6-4	17.4	440	30	600	JJS-30	UL class T
-17A0-4	25.2	560	35	600	JJS-35	UL class T
-25A0-4	31.8	400	40	600	JJS-40	UL class T
-033A-4	40.9	504	60	600	JJS-60	UL class T
-038A-4	49	640	70	600	JJS-70	UL class T
-045A-4	55.7	800	70	600	JJS-70	UL class T
-050A-4	55.7	800	70	600	JJS-70	UL class T

Alternate short-circuit protection

■ Miniature circuit breakers (IEC)

The protective characteristics of the circuit breakers depend on the type, construction and settings of the breakers. There are also limitations pertaining to the short-circuit capacity of the supply network. Your local ABB representative can help you in selecting the breaker type when the supply network characteristics are known.



WARNING!

Due to the inherent operating principle and construction of circuit breakers, independent of the manufacturer, hot ionized gases can escape from the breaker enclosure in case of a short-circuit. To ensure safe use, pay special attention to the installation and placement of the breakers. Obey the manufacturer's instructions.

You can use the circuit breakers listed below. You can also use other circuit breakers with the drive if they provide the same electrical characteristics. ABB does not assume any liability whatsoever for the correct function and protection with circuit breakers not listed below. Furthermore, if the recommendations given by ABB are not obeyed, the drive can experience problems the warranty does not cover.

Note: Miniature circuit breakers with or without fuses have not been evaluated for use as short circuit protection in USA (UL) environments.

ACS180-04...	Frame	Miniature circuit breaker
		ABB type
1-phase $U_n = 200 \dots 240 \text{ V}$		
-02A4-1	R0	S201P-B10NA
-03A7-1	R0	S201P-B10NA
-04A8-1	R0	S201P-B16NA
-06A9-1	R1	S201P-B20NA
-07A8-1	R1	S201P-B25NA
-09A8-1	R1	S201P-B32NA
-12A2-1	R2	S201P-B40NA
3-phase $U_n = 200 \dots 240 \text{ V}$		
-02A4-2	R0	S203P-Z6NA
-03A7-2	R0	S203P-Z8NA
-04A8-2	R0	S203P-Z10NA
-06A9-2	R1	S203P-Z16NA
-07A8-2	R1	S203P-Z20NA
-09A8-2	R1	S203P-Z20NA
-15A6-2	R2	S203P-Z32NA
-17A5-2	R2	S203P-Z32NA
-25A0-2	R3	S203P-Z50NA
-033A-2	R3	S203P-Z63NA
-048A-2	R4	Contact ABB
-055A-2	R4	Contact ABB
3-phase $U_n = 380 \dots 415 \text{ V}$		
-01A8-4	R0	S203P-B6
-02A6-4	R0	S203P-B6
-03A3-4	R0	S203P-B6
-04A0-4	R1	S203P-B8
-05A6-4	R1	S203P-B10
-07A2-4	R1	S203P-B16
-09A4-4	R1	S203P-B16
-12A6-4	R2	S203P-B25
-17A0-4	R2	S203P-B40

ACS180-04...	Frame	Miniature circuit breaker	
		ABB type	
-25A0-4	R3	S203P-B50	
-033A-4	R3	S203P-B63	
-038A-4	R4	S803S-B80	
-045A-4	R4	S803-B100	
-050A-4	R4	S803-B100	

■ **Manual self-protected combination motor controller – Type E USA (UL (NEC))**

You can use the ABB Type E manual motor protectors (MMP) MS132 & S1-M3-25, MS165-xx and MS5100-100 as an alternative to the recommended fuses as a means of branch circuit protection. This is in accordance with the National Electrical Code (NEC). When the correct ABB Type E manual motor protector is selected from the table and used for branch circuit protection, the drive is suitable for use in a circuit capable of delivering no more than 65 kA rms symmetrical amperes at the maximum rated voltage of the drive. See the table below for the appropriate MMP types and minimum enclosure volume of IP20 / UL open type drive mounted in an enclosure.

If you use a manual motor protector for the branch circuit protection of the drive, install the drive into a metal enclosure.

Note: The UL Listing of drive and MMP combinations applies only to drives that are mounted in appropriately sized metal enclosures that are capable of containing any drive component failure.

Type ACS180-04...	Frame	MMP type ^{1) 2) 3)}	Minimum enclosure volume ⁴⁾	
			dm ³	in ³
1-phase $U_n = 200...240$ V				
02A4-1	R0	MS132-6.3 & S1-M3-25 ⁵⁾	15	890
03A7-1	R0	MS132-10 & S1-M3-25 ⁵⁾	15	890
04A8-1	R0	MS132-10 & S1-M3-25 ⁵⁾	15	890
06A9-1	R1	MS165-16	15.3	890
07A8-1	R1	MS165-20	15	890
09A8-1	R1	MS165-25	15	890
12A2-1	R2	MS165-32	16	970
3-phase $U_n = 200...240$ V				
02A4-2	R0	MS132-6.3 & S1-M3-25 ⁵⁾	15	890
03A7-2	R0	MS132-10 & S1-M3-25 ⁵⁾	15	890
04A8-2	R0	MS132-10 & S1-M3-25 ⁵⁾	15	890
06A9-2	R1	MS165-16	15	890
07A8-2	R1	MS165-20	15	890

Type ACS180-04...	Frame	MMP type 1) 2) 3)	Minimum enclosure volume 4)	
			dm ³	in ³
09A8-2	R1	MS165-20	15	890
15A6-2	R2	MS165-25	16	970
17A5-2	R2	MS165-32	16	970
3-phase $U_n = 440 \dots 480 \text{ V}$				
01A8-4	R0	MS132-4.0 & S1-M3-25 ⁵⁾	15	890
02A6-4	R0	MS132-6.3 & S1-M3-25 ⁵⁾	15	890
03A3-4	R0	MS132-6.3 & S1-M3-25 ⁵⁾	15	890
04A0-4	R1	MS132-10 & S1-M3-25 ⁵⁾	15	890
05A6-4	R1	MS132-10 & S1-M3-25 ⁵⁾	15	890
07A2-4	R1	MS165-16	15	890
09A4-4	R1	MS165-16	15	890
12A6-4	R2	MS165-25	16	970
17A0-4	R2	MS165-32	16	970
25A0-4	R3	MS165-42	30.3	1850
033A-4	R3	MS165-54	30.3	1850
038A-4	R4	MS165-65	75	4577
045A-4	R4	MS5100-100 / MS165-73	75	4577
050A-4	R4	MS5100-100 / MS165-80	75	4577

- 1) All manual motor protectors listed are Type E self-protected up to 65 kA, except MS165-80 which is Type E self-protected up to 50 kA. See the ABB manual motor starter catalog (1SBC100214C0201) for complete technical data on the ABB Type E manual motor protectors. In order for these manual motor protectors to be used for branch circuit protection, they must be UL listed Type E manual motor protectors, otherwise they can be used only as an At Motor Disconnect. "At Motor Disconnect" is a disconnect just ahead of the motor on the load side of the panel.
- 2) 480Y/277 V delta systems only: Short-circuit protective devices with slash voltage ratings (e.g. 480Y/277 V AC) can be applied only in solidly grounded networks where the voltage from line-to-ground does not exceed the lower of the two ratings (e.g. 277 V AC), and the voltage from line-to-line does not exceed the higher of the two ratings (e.g. 480 V AC). The lower rating represents the device's interrupting capability per pole.
- 3) Manual motor protectors may require adjusting the trip limit from the factory setting at or above the drive input Amps to avoid nuisance tripping. If the manual motor protector is set to the maximum current trip level and nuisance tripping is occurring, select the next size MMP. (MS132-10 is the highest size in the MS132 frame size to meet Type E at 65 kA; the next size up is MS165-16.)
- 4) For all drives, the enclosure must be sized to accommodate the specific thermal considerations of the application as well as provide free space for cooling. Refer to the technical data. For UL only: The minimum enclosure volume is specified in the UL listing when applied with the ABB Type E MMP shown in the table.
- 5) Requires the use of the S1-M3-25 line side feeder terminal with the manual motor protector to meet Type E self-protection class.

Dimensions and weights

Frame size	H1		H2		H3		W		D		M1		M2		Weight	
	mm	in	mm	in	mm	in	mm	in	mm	in	mm	in	mm	in	kg	lb
R0	174	6.85	209	8.23	136	5.35	70	2.76	143	5.63	60	2.36	164	6.46	0.92	2.03
R1	190	7.48	220	8.66	152	5.98	70	2.76	143	5.63	60	2.36	180	7.09	1.24	2.73
R2	202	7.95	230	9.06	164.5	6.48	120	4.72	143	5.63	106	4.17	190.5	7.5	1.92	4.23
R3	205	8.07	241	9.5	164.5	6.48	170	6.69	174	6.85	148	5.83	191	7.52	3.3	7.28
R4	205	8.07	240	9.45	164.5	6.48	260	10.24	178.6	7.03	234	9.21	191	7.52	5.3	11.69

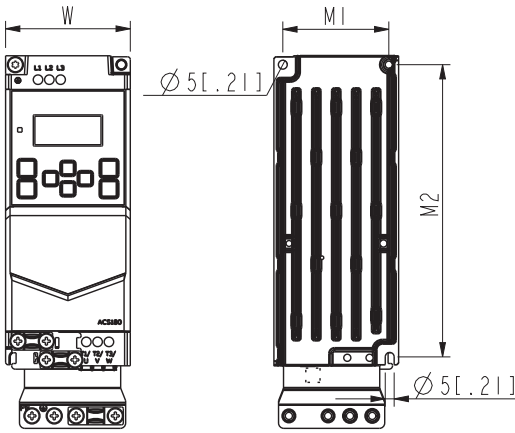

Symbols

- H1** Height back
- H2** Height with grounding plate
- H3** Height front
- W** Width
- D** Depth
- M1** Mounting hole distance 1
- M2** Mounting hole distance 2

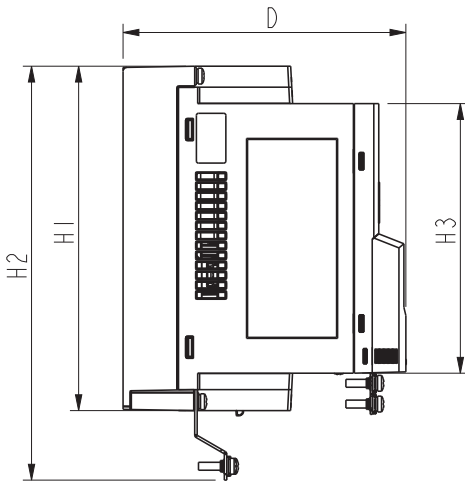

Free space requirements

Frame size	Above		Below		Sides	
	mm	in	mm	in	mm	in
R0	75	3	75	3	50 ¹⁾	2
R1-R4	75	3	75	3	0	0

Note: 1) If ambient temperature is below 40°C (104 F), modules can be installed side-by-side.

Losses, cooling data and noise

Drives with frame size R0 have natural convection cooling. Drives with frame size R1...R4 have a cooling fan. The air flow direction is from bottom to top.

Note: power losses are given for nominal supply voltage, default switching frequency, and rated output current/power. Changing these factors may result in increased power losses.

ACS180-04...	Typical power loss ¹⁾		Air flow		Noise	Frame size
	W	BTU/h	m ³ /h	CFM	dB(A)	
1-phase $U_n = 200 \dots 240 \text{ V}$						
-02A4-1	26	88	-	-	-	R0
-03A7-1	42	143	-	-	-	R0
-04A8-1	48	165	-	-	-	R0
-06A9-1	64	218	27.26	16.04	51.8	R1
-07A8-1	69	235	27.26	16.04	51.8	R1
-09A8-1	84	285	27.26	16.04	51.8	R1
-12A2-1	141	483	130.44	76.77	62	R2
3-phase $U_n = 200 \dots 240 \text{ V}$						
-02A4-2	23	78	-	-	-	R0
-03A7-2	37	126	-	-	-	R0
-04A8-2	44	150	-	-	-	R0
-06A9-2	58	198	27.26	16.04	51.8	R1
-07A8-2	63	215	27.26	16.04	51.8	R1
-09A8-2	76	259	27.26	16.04	51.8	R1
-15A6-2	168	573	130.44	76.77	62	R2
-17A5-2	198	676	130.44	76.77	62	R2
-25A0-2	389	1327	128	75.34	66	R3
-033A-2	407	1389	128	75.34	66	R3
-048A-2	564	1924	150	88.29	69	R4
-055A-2	677	2310	150	88.29	69	R4

ACS180-04...	Typical power loss ¹⁾		Air flow		Noise	Frame size
	W	BTU/h	m ³ /h	CFM	dB(A)	
3-phase U_n = 380 ... 480 V						
-01A8-4	22	75	-	-	-	R0
-02A6-4	29	99	-	-	-	R0
-03A3-4	38	130	-	-	-	R0
-04A0-4	46	157	36.29	21.36	50.9	R1
-05A6-4	69	235	36.29	21.36	50.9	R1
-07A2-4	86	293	36.29	21.36	50.9	R1
-09A4-4	119	406	36.29	21.36	50.9	R1
-12A6-4	157	536	130.44	76.77	62	R2
-17A0-4	224	764	130.44	76.77	62	R2
-25A0-4	382	1303	128	75.34	66	R3
-033A-4	551	1880	128	75.34	66	R3
-038A-4	480	1638	150	88.29	69	R4
-045A-4	565	1928	150	88.29	69	R4
-050A-4	656	2238	150	88.29	69	R4

¹⁾ Typical drive losses when it operates at 90% of the motor nominal frequency and 100% of the drive nominal.

Terminal data for the power cables

The first table shows the terminal data in SI units. The second table shows the terminal data in imperial units.

ACS180-04...	L1, L2, L3, T1/U, T2/V, T3/W, R-, R+ / UDC+			PE		
	Minimum (sol-id/stranded)	Maximum (sol-id/stranded)	Tightening torque	Minimum (sol-id/stranded)	Maximum (sol-id/stranded)	Tightening torque
	mm ²	mm ²	N·m	mm ²	mm ²	N·m
1-phase U_n = 200 ... 240 V						
-02A4-1	0.2/0.2	6/4	0.5...0.6	4/2.5	6/4	1.2
-03A7-1	0.2/0.2	6/4	0.5...0.6	4/2.5	6/4	1.2
-04A8-1	0.2/0.2	6/4	0.5...0.6	4/2.5	6/4	1.2
-06A9-1	0.2/0.2	6/6	0.5...0.6	4/2.5	6/4	1.2
-07A8-1	0.2/0.2	6/6	0.5...0.6	4/2.5	6/4	1.2
-09A8-1	0.2/0.2	6/6	0.5...0.6	4/2.5	6/4	1.2
-12A2-1	0.2/0.2	6/6	0.5...0.6	4/2.5	6/4	1.2
3-phase U_n = 200 ... 240 V						
-02A4-2	0.2/0.2	6/6	0.5...0.6	4/2.5	6/4	1.2

ACS180-04...	L1, L2, L3, T1/U, T2/V, T3/W, R-, R+/ UDC+			PE		
	Minimum (sol- id/stran- ded)	Maximum (sol- id/stran- ded)	Tightening torque	Minimum (sol- id/stran- ded)	Maximum (sol- id/stran- ded)	Tightening torque
	mm ²	mm ²	N·m	mm ²	mm ²	N·m
-03A7-2	0.2/0.2	6/6	0.5...0.6	4/2.5	6/4	1.2
-04A8-2	0.2/0.2	6/6	0.5...0.6	4/2.5	6/4	1.2
-06A9-2	0.2/0.2	6/6	0.5...0.6	4/2.5	6/4	1.2
-07A8-2	0.2/0.2	6/6	0.5...0.6	4/2.5	6/4	1.2
-09A8-2	0.2/0.2	6/6	0.5...0.6	4/2.5	6/4	1.2
-15A6-2	0.2/0.2	6/6	0.5...0.6	4/2.5	6/4	1.2
-17A5-2	0.2/0.2	6/6	0.5...0.6	4/2.5	6/4	1.2
-25A0-2	0.5/0.5	10/6	1.2...1.5	0.5	16/16	1
-033A-2	0.5/0.5	10/6	1.2...1.5	0.5	16/16	1
-048A-2	0.5/0.5	25/16	2.5...3.7	0.5	16/16	1
-055A-2	0.5/0.5	25/16	2.5...3.7	0.5	16/16	1
3-phase $U_n = 380 \dots 415 \text{ V}$						
-01A8-4	0.2/0.2	6/4	0.5...0.6	4/2.5	6/4	1.2
-02A6-4	0.2/0.2	6/4	0.5...0.6	4/2.5	6/4	1.2
-03A3-4	0.2/0.2	6/4	0.5...0.6	4/2.5	6/4	1.2
-04A0-4	0.2/0.2	6/4	0.5...0.6	4/2.5	6/4	1.2
-05A6-4	0.2/0.2	6/4	0.5...0.6	4/2.5	6/4	1.2
-07A2-4	0.2/0.2	6/4	0.5...0.6	4/2.5	6/4	1.2
-09A4-4	0.2/0.2	6/4	0.5...0.6	4/2.5	6/4	1.2
-12A6-4	0.2/0.2	6/6	0.5...0.6	4/2.5	6/4	1.2
-17A0-4	0.2/0.2	6/6	0.5...0.6	4/2.5	6/4	1.2
-25A0-4	0.5/0.5	10/6	1.2...1.5	0.5	16/16	1
-033A-4	0.5/0.5	10/6	1.2...1.5	0.5	16/16	1
-038A-4	0.5/0.5	25/16	2.5...3.7	0.5	16/16	1
-045A-4	0.5/0.5	25/16	2.5...3.7	0.5	16/16	1
050A-4	0.5/0.5	25/16	2.5...3.7	0.5	16/16	1
ACS180-04...	L1, L2, L3, T1/U, T2/V, T3/W, R-, R+/ UDC+			PE		
	Minimum	Maximum	Tightening torque	Minimum	Maximum	Tightening torque
	AWG	AWG	lbf·in	AWG	AWG	lbf·in
1-phase $U_n = 200 \dots 240 \text{ V}$						
-02A4-1	18	10	5	12	10	10.6
-03A7-1	18	10	5	12	10	10.6

112 Technical data

ACS180-04...	L1, L2, L3, T1/U, T2/V, T3/W, R-, R+/ UDC+			PE		
	Minimum	Maximum	Tightening torque	Minimum	Maximum	Tightening torque
	AWG	AWG	lbf-in	AWG	AWG	lbf-in
-04A8-1	18	10	5	12	10	10.6
-06A9-1	18	8	5	12	10	10.6
-07A8-1	18	8	5	12	10	10.6
-09A8-1	18	8	5	12	10	10.6
-12A2-1	18	8	5	12	10	10.6
3-phase $U_n = 200 \dots 240 \text{ V}$						
-02A4-2	18	10	5	12	10	10.6
-03A7-2	18	10	5	12	10	10.6
-04A8-2	18	10	5	12	10	10.6
-06A9-2	18	8	5	12	10	10.6
-07A8-2	18	8	5	12	10	10.6
-09A8-2	18	8	5	12	10	10.6
-15A6-2	18	8	5	12	10	10.6
-17A5-2	18	8	5	12	10	10.6
-25A0-2	18	8/10	11...13	20	6	10.6
-033A-2	18	8/10	11...13	20	6	10.6
-048A-2	18	4/6	22...32	20	6	10.6
-055A-2	18	4/6	22...32	20	6	10.6
3-phase $U_n = 440 \dots 480 \text{ V}$						
-01A8-4	18	10	5	12	10	10.6
-02A6-4	18	10	5	12	10	10.6
-03A3-4	18	10	5	12	10	10.6
-04A0-4	18	10	5	12	10	10.6
-05A6-4	18	10	5	12	10	10.6
-07A2-4	18	10	5	12	10	10.6
-09A4-4	18	10	5	12	10	10.6
-12A6-4	18	8	5	12	10	10.6
-17A0-4	18	8	5	12	10	10.6
-25A0-4	18	8/10	11...13	20	6	10.6
-033A-4	18	8/10	11...13	20	6	10.6
-038A-4	18	4/6	22...32	20	6	10.6
-045A-4	18	4/6	22...32	20	6	10.6
050A-4	18	4/6	22...32	20	6	10.6

Note:

- The minimum specified wire size does not necessarily have sufficient current carrying capacity at maximum load.
- The terminals do not accept a conductor that is one size larger than the maximum specified wire size.
- The maximum number of conductors per terminal is 1.

Typical power cable sizes

ACS180-04...	Cable conductor sizes (mm ²) ¹⁾	AWG	Frame
1-phase $U_n = 200 \dots 240 \text{ V}$			
-02A4-1	3×1.5 + 1.5	16	R0
-03A7-1	3×1.5 + 1.5	16	R0
-04A8-1	3×1.5 + 1.5	16	R0
-06A9-1	3×1.5 + 1.5	16	R1
-07A8-1	3×2.5 + 2.5	14	R1
-09A8-1	3×2.5 + 2.5	14	R1
-12A2-1	3×2.5 + 2.5	14	R2
3-phase $U_n = 200 \dots 240 \text{ V}$			
-02A4-2	3×1.5 + 1.5	16	R0
-03A7-2	3×1.5 + 1.5	16	R0
-04A8-2	3×1.5 + 1.5	16	R0
-06A9-2	3×1.5 + 1.5	16	R1
-07A8-2	3×2.5 + 2.5	14	R1
-09A8-2	3×2.5 + 2.5	14	R1
-15A6-2	3×6 + 6	10	R2
-17A5-2	3×6 + 6	10	R2
-25A0-2	3×6 + 6	10	R3
-033A-2	3×10 + 10	8	R3
-048A-2	3×25 + 16	4	R4
-055A-2	3×25 + 16	4	R4
3-phase $U_n = 380 \dots 480 \text{ V}$			
-01A8-4	3×1.5 + 1.5	16	R0
-02A6-4	3×1.5 + 1.5	16	R0
-03A3-4	3×1.5 + 1.5	16	R0
-04A0-4	3×1.5 + 1.5	16	R1
-05A6-4	3×1.5 + 1.5	16	R1
-07A2-4	3×2.5 + 2.5	14	R1
-09A4-4	3×2.5 + 2.5	14	R1

ACS180-04...	Cable conductor sizes (mm ²) ¹⁾	AWG	Frame
-12A6-4	3×2.5 + 2.5	14	R2
-17A0-4	3×6 + 6	10	R2
-25A0-4	3×6 + 6	10	R3
-033A-4	3×10 + 10	8	R3
-038A-4	3×10 + 10	8	R4
-045A-4	3×16 + 16	6	R4
-050A-4	3×25 + 16	4	R4

¹⁾ Size of typical power cable (symmetrical, shielded, three-phase copper cable). Note that for the input power connection, you may have to use two separate PE conductors (IEC 61800-5-1).

Terminal data for the control cables

Wire size		Torque	
mm ²	AWG	N·m	lbf·in
0.5 - 1.5	22 - 16	n/a	n/a

External EMC filters

The table shows the external EMC filters. See also EMC compatibility and motor cable length and Technical data (page 91).

ACS180-04...	EMC filter type	
	ABB order code	Schaffner order code
1-phase $U_n = 200 \dots 240 \text{ V}$		
02A4-1	RFI-12	FS 21754-16.1-07
03A7-1	RFI-12	FS 21754-16.1-07
04A8-1	RFI-12	FS 21754-16.1-07
06A9-1	RFI-12	FS 21754-16.1-07
07A8-1	RFI-12	FS 21754-16.1-07
09A8-1	Contact ABB	Contact ABB
12A2-1	Contact ABB	Contact ABB
3-phase $U_n = 200 \dots 240 \text{ V}$		
02A4-2	RFI-311	FS43566-16-44
03A7-2	RFI-311	FS43566-16-44
04A8-2	RFI-311	FS43566-16-44
06A9-2	RFI-311	FS43566-16-44
07A8-2	RFI-311	FS43566-16-44
09A8-2	RFI-311	FS43566-16-44
15A6-2	RFI-321	FS43566-30-33
17A5-2	RFI-321	FS43566-30-33
25A0-2	RFI-33	FN 3258-30-33

ACS180-04...	EMC filter type	
	ABB order code	Schaffner order code
033A-2	RFI-34	FN 3258-100-35
048A-2	RFI-34	FN 3258-100-35
055A-2	RFI-34	FN 3258-100-35
3-phase $U_n = 380 \dots 415 \text{ V}$		
01A8-4	RFI-311	FS 43566-16-44
02A6-4	RFI-311	FS 43566-16-44
03A3-4	RFI-311	FS 43566-16-44
04A0-4	RFI-311	FS 43566-16-44
05A6-4	RFI-311	FS 43566-16-44
07A2-4	RFI-311	FS 43566-16-44
09A4-4	RFI-311	FS 43566-16-44
12A6-4	RFI-321	FS 43566-30-33
17A0-4	RFI-321	FS 43566-30-33
25A0-4	RFI-33	FN 3258-30-33
033A-4	RFI-34	FN 3258-100-35
038A-4	RFI-34	FN 3258-100-35
045A-4	RFI-34	FN 3258-100-35
050A-4	RFI-34	FN 3258-100-35

If you use an external EMC filter, you must disconnect the internal EMC filter. Refer to the electrical installation instructions.

Electrical power network specification

Voltage (U₁)	ACS180-04x-xxxx-1 drives: 1-phase 200 ... 240 V AC -15% ... +10% ACS180-04x-xxxx-2 drives: 3-phase 200 ... 240 V AC -15% ... +10% ACS180-04x-xxxx-4 drives: 3-phase 380 ... 480 V AC -15% ... +10%
Network type	Public low-voltage networks. Symmetrically grounded TN-S system, IT (ungrounded), corner-grounded delta. Consult ABB before connecting to other systems (for example, TT, or midpoint grounded delta). ACS180-04N-...-4 doesn't support corner-grounded delta network.
Rated conditional short-circuit current (IEC 61800-5-1)	65 kA when protected by fuses given in the fuse tables.

Short-circuit current protection (UL 61800-5-1, CSA C22.2 No. 274-13)	US and Canada: The drive is suitable for use on a circuit capable of delivering not more than 100 kA symmetrical amperes (rms) at 480 V maximum when protected by fuses given in the fuse table. The drive is also suitable for use on a circuit capable of delivering not more than 65 kA symmetrical amperes (rms) at 480V maximum when protected by the specific manual self-protected Type E combination motor controllers given in the manual self-protected combination motor controller table, provided the drive is mounted within an enclosure of adequate minimum volume, and the assembly complies with all applicable footnotes of the table.
Mains choke	Use a mains choke if the network's line impedance is low (less than 0.3% total system impedance of all the ACS180 drives in the installation), or has voltage imbalance, or harmonic distortion that make the input current bigger than the nominal input current ratings. You can use one choke for several drives as long as the choke current rating is not exceeded.
Frequency (f1)	47 to 63 Hz, maximum rate of change 17%/s
Imbalance	Max. ±3% of nominal phase to phase input voltage
Fundamental power factor (cos phi)	0.98 (at nominal load)

Motor connection data

Motor type	Asynchronous induction motor or permanent magnet synchronous motor
Voltage (U2)	0 to U ₁ , 3-phase symmetrical, U _{max} at the field weakening point
Short-circuit protection (IEC 61800-5-1, UL 61800-5-1)	The motor output is short-circuit proof by IEC 61800-5-1 and UL 61800-5-1.
Frequency (f2)	0...599 Hz
Frequency resolution	0.01 Hz
Current	See the rating information.
Switching frequency	4, 8, or 12 kHz

■ Motor cable length

Operational functionality and motor cable length

The drive is designed to operate with optimum performance with the following maximum motor cable lengths. The motor cable lengths may be extended with output chokes as shown in the table.

Frame	Maximum motor cable length	
	m	ft
Standard drive, without external options		
R0	30	98
R1	50	164

Frame	Maximum motor cable length	
	m	ft
R2	100	328
R3	100	328
R4	100	328
With external output chokes		
R0	50	164
R1	75	246
R2	150	492
R3	150	492
R4	150	492

Note: In multimotor systems, the calculated sum of all motor cable lengths must not exceed the maximum motor cable length given in the table.

EMC compatibility and motor cable length

To comply with the EMC limits in the European EMC Directive (standard IEC/EN 61800-3), use these maximum motor cable lengths for the 4 kHz switching frequency.

Frame	Maximum motor cable length, 4 kHz					
	Class 1 ¹⁾		Class 2		Class 3	
	m	ft	m	ft	m	ft
With internal EMC filter						
1-phase $U_n = 200 \dots 240 \text{ V}$						
R0	-	-	5	16	10	33
R1	-	-	5	16	10	33
R2	-	-	5	16	10	33
3-phase $U_n = 380 \dots 415 \text{ V}$						
R0	-	-	-	-	10	33
R1	-	-	-	-	10	33
R2	-	-	-	-	10	33
R3	-	-	-	-	30	98
R4	-	-	-	-	30	98
With optional external EMC filter						
1-phase $U_n = 200 \dots 240 \text{ V}$						
R0	10	33	30	98	-	-
R1	10	33	30	98	-	-
R2	10	33	30	98	-	-
3-phase $U_n = 200 \dots 240 \text{ V}$						
R0	-	-	30	98	30	98
R1	-	-	30	98	30	98
R2	-	-	30	98	30	98
R3	-	-	20	66	20	66
R4	-	-	20	66	20	66
3-phase $U_n = 380 \dots 415 \text{ V}$						
R0	10	33	30	98	-	-
R1	10	33	30	98	-	-
R2	10	33	30	98	-	-
R3	40	131	40	131	40	131
R4	30	98	30	98	30	98

¹⁾ Category C1 with conducted emissions only. Radiated emissions are not compatible when measured with the standard emission measurement setup and must be measured on cabinet and machine installations for each case.

Note:

- Radiated emissions are according to C2 with single phase ACS180-04S...-1 drives. For ACS180-04S...-4 drives, use a metal enclosure to fulfill radiated emissions C2/C1 limits with an external EMC filter.
- External EMC filter must be used together with ACS180-04S-... drives.
- For ACS180-04N... drives, the maximum motor cable lengths are according to the motor cable length table. The EMC category for these drives is C4.
- For ACS180-04S-...-2 drives, the EMC category is C4. In order to achieve higher EMC category, must use external EMC filters.

Control connection data

Analog inputs (AI1, AI2)	Voltage signal, single-ended	0 ... 10 V DC (10% overrange, 11 V DC max.) $R_{in} = 38 \text{ kohm}$
	Current signal, single-ended	0 ... 20 mA (10% overrange, 22 mA max.) $R_{in} = 205 \text{ ohm}$
	Inaccuracy	$\leq 1.0\%$, of full scale
	Potentiometer reference value	10 V DC $\pm 1\%$, max. load current 10 mA
Analog output (AO)	Current output mode	0 ... 20 mA (10% overrange, 22 mA max.) into maximum 500 ohm load
	Voltage output mode	0 ... 10 V DC (10% overrange, 11 V DC max.) into 200 kohm minimum load (resistive)
	Inaccuracy	$\leq 1.5\%$, of full scale
Auxiliary voltage output (+24V)	As output	+24 V DC $\pm 10\%$, max. 100 mA
Digital inputs (DI1...DI4)	Voltage	12 ... 24 V DC (int. or ext. supply) max. 30 V DC.
	Type	PNP and NPN
	Input impedance	$R_{in} = 2 \text{ kohm}$
Digital output(DO)	As outputs	
	Type	Transistor output PNP
	Max. switching voltage	30 V DC
	Max. switching current	60 mA / 30 V DC, short-circuit protected
Relay output (RA, RB, RC)	Type	1 form C (NO + NC)
	Max. switching voltage	250 V AC / 30 V DC
	Max. switching current	2 A
Frequency input (FI)	10 Hz...16 kHz DI3 and DI4 can be used as digital or frequency inputs.	

STO interface (SGND, S+, S1, S2)	Refer to The Safe torque off function (page 143)
---	--

Brake resistor connection data

Short-circuit protection (IEC 61800-5-1, IEC 60439-1, UL 61800-5-1)	The brake resistor output is conditionally short-circuit proof by IEC/EN 61800-5-1 and UL 61800-5-1. Rated conditional short-circuit current is as defined in IEC 60439-1.
--	---

Energy efficiency data (ecodesign)

Energy efficiency data according to IEC 61800-9-2 is available from the ecodesign tool (<https://ecodesign.drivesmotors.abb.com/>).



Energy efficiency data is not provided for the 1~230 V drives. The drives with one phase input are not in the scope of the EU ecodesign requirements (Regulation EU/2019/1781) or the UK ecodesign requirements (Regulation SI 2021 No. 745).

Degrees of protection

Degree of protection (IEC/EN 60529)	IP20 (cabinet installation): Standard enclosure. The drive must be installed in a cabinet to fulfill the requirements for shielding from contact.
Enclosure types (UL 61800-5-1)	UL Open Type. For indoor use only.
Overvoltage category (IEC 60664-1)	III
Protective classes (IEC/EN 61800-5-1)	I

Ambient conditions

Environmental limits for the drive are given below. The drive must be used in a heated indoor controlled environment.

Requirement	Operation installed for stationary use	Storage in the protective package	Transportation in the protective package
Installation site altitude	0 ... 1000 m above sea level without derating. 1000 ... 2000 m above sea level with derating.	-	-
Surrounding air temperature at heavy duty rating	For frame size R0: -10 ... +50 °C (14 ... 122 °F) without derating. Temperature above 50 °C not allowed. For frame sizes R1...R4: -10 ... +50 °C (14 ... 122 °F) without derating. 50 ... 60 °C (122 ... 140 °F) with derating. No frost allowed.	-40 ... +70 °C (-40 ... 158 °F)	-40 ... +70 °C (-40 ... 158 °F)
Surrounding air temperature at light duty rating	For frame size R0: -10 ... +40 °C (14 ... 104 °F) without derating. +40 ... +50 °C (104 ... 122 °F) with derating. For frame sizes R1...R2: -10 ... +40 °C (14 ... 104 °F) without derating. +40 ... +60 °C (104 ... 104 °F) with derating. For frame sizes R3...R4: -10 ... +50 °C (14 ... 122 °F) without derating. +50 ... +60 °C (122 ... 140 °F) with derating. No frost allowed.		
Relative humidity	<95% (IEC 60068-2-78) without condensation		
Contamination levels (IEC 60721-3-3)	Class 3C2	Class 1C2	Class 2C2
	Class 3S2	Class 1S2	Class 2S2
Sinusoidal vibration (IEC 61800-5-1 to comply with EN 50178)	Class 3M4	-	-
Shock (EN 60068-2-31 to comply with EN 50178)	Not allowed	According to ISTA 1A. Max. 100 m/s ² (330 ft/s ²), 11 ms.	According to ISTA 1A. Max. 100 m/s ² (330 ft/s ²), 11 ms.
Free fall	Not allowed	76 cm (30 in)	76 cm (30 in)

Materials

Drive enclosure	Hot-dip zinc coated steel sheet 1.5 mm, thickness of coating 20 micrometers. Die casting and extruded aluminum AlSi. PC/ABS 2...3 mm, PC+10%GF 2.5...3 mm, all in color NCS 1502-Y (RAL 9002 / PMS 420 C).
Package	Corrugated cardboard

Disposal

The main parts of the drive can be recycled to preserve natural resources and energy. Product parts and materials should be dismantled and separated.

Generally all metals, such as steel, aluminum, copper and its alloys, and precious metals can be recycled as material. Plastics, rubber, cardboard and other packaging material can be used in energy recovery. Printed circuit boards and large electrolytic capacitors need selective treatment according to IEC 62635 guidelines. To aid recycling, plastic parts are marked with an appropriate identification code.

Contact your local ABB distributor for further information on environmental aspects and recycling instructions for professional recyclers. End of life treatment must follow international and local regulations.

Applicable standards

The drive complies with the following standards:

EN ISO 13849-1:2015	Safety of machinery – Safety related parts of the control systems – Part 1: general principles for design
EN ISO 13849-2:2012	Safety of machinery – Safety-related parts of the control systems – Part 2: Validation
EN 60204-1:2006 + A1:2009 + AC:2010	Safety of machinery. Electrical equipment of machines. Part 1: General requirements. Provisions for compliance: The final assembler of the machine is responsible for installing <ul style="list-style-type: none"> • an emergency-stop device • a supply disconnecting device
EN 62061:2005 + AC:2010 + A1:2013 + A2:2015	Safety of machinery – Functional safety of safety-related electrical, electronic and programmable electronic control systems
EN 61800-3:2004 + A1:2012 IEC61800-3:2017	Adjustable speed electrical power drive systems. Part 3: EMC requirements and specific test methods
EN 61800-5-1:2007 IEC61800-5-1:2007+AMD1:2016	Adjustable speed electrical power drive systems – Part 5-1: Safety requirements – Electrical, thermal and energy
ANSI/UL 61800-5-1:2018	UL Standard for adjustable speed electrical power drive systems – Part 5-1: Safety requirements – Electrical, thermal and energy
CSA C22.2 No. 274-17	Adjustable speed drives

Markings

	<p>CE mark Product complies with the applicable European Union legislation. For fulfilling the EMC requirements, see the additional information concerning the drive EMC compliance (IEC/EN 61800-3).</p>
	<p>UKCA (UK Conformity Assessed) mark Product complies with the applicable United Kingdom's legislation (Statutory Instruments). Marking is required for products being placed on the market in Great Britain (England, Wales and Scotland).</p>
	<p>TÜV Safety Approved mark (functional safety) Product contains Safe torque off and possibly other (optional) safety functions which are certified by TÜV according to the relevant functional safety standards. Applicable to drives and inverters; not applicable to supply, brake or DC/DC converter units or modules.</p>
	<p>UL Listed mark for USA and Canada Product has been tested and evaluated against the relevant North American standards by the Underwriters Laboratories. Valid with rated voltages up to 600 V.</p>
	<p>RCM mark Product complies with Australian and New Zealand requirements specific to EMC, telecommunications and electrical safety. For fulfilling the EMC requirements, see the additional information concerning the drive EMC compliance (IEC/EN 61800-3).</p>
	<p>EAC (Eurasian Conformity) mark Product complies with the technical regulations of the Eurasian Customs Union. EAC mark is required in Russia, Belarus and Kazakhstan.</p>
	<p>Electronic Information Products (EIP) symbol including an Environment Friendly Use Period (EFUP). Product is compliant with the People's Republic of China Electronic Industry Standard (SJ/T 11364-2014) about hazardous substances. The EFUP is 20 years. China RoHS II Declaration of Conformity is available from https://library.abb.com.</p>
	<p>WEEE mark At the end of life the product should enter the recycling system at an appropriate collection point and not placed in the normal waste stream.</p>
	<p>KC mark Product complies with Korean Registration of Broadcasting and Communications Equipment Clause 3, Article 58-2 of Radio Waves Act.</p>

Compliance with EN 61800-3

■ Definitions

EMC stands for Electromagnetic Compatibility. It is the ability of electrical/electronic equipment to operate without problems within an electromagnetic environment. Likewise, the equipment must not disturb or interfere with any other product or system within its locality.

First environment includes establishments connected to a low-voltage network which supplies buildings used for domestic purposes.

Second environment includes establishments connected to a network not supplying domestic premises.

Drive of category C1: drive of rated voltage less than 1000 V and intended for use in the first environment.

Drive of category C2: drive of rated voltage less than 1000 V and intended to be installed and started up only by a professional when used in the first environment.

Note: A professional is a person or organization having necessary skills in installing and/or starting up power drive systems, including their EMC aspects.

Drive of category C3: drive of rated voltage less than 1000 V and intended for use in the second environment and not intended for use in the first environment.

Drive of category C4: drive of rated voltage equal to or above 1000 V, or rated current equal to or above 400 A, or intended for use in complex systems in the second environment.

■ Category C1

This is applicable to ACS180-04S-...-1/-4 drives with an external EMC C1 filter.

The drive complies with the conducted emission limits of the standard with the following provisions:

1. The optional EMC filter is selected according to section [External EMC filters \(page 114\)](#), and the filter is installed as specified in the EMC filter manual.
2. The motor and control cables are selected as specified in this manual. The EMC recommendations are obeyed.
3. The maximum motor cable length does not exceed the specified maximum value. See [EMC compatibility and motor cable length \(page 118\)](#).
4. The drive is installed according to the instructions given in this manual.

This product can cause radio-frequency inference. In a residential or domestic environment, supplementary mitigation measures may be required in addition to the requirements listed above for the CE compliance.

■ Category C2

This is applicable to ACS180-04S-...-1 drives with an internal EMC C2 filter.

The drive complies with the standard with the following provisions:

1. The motor and control cables are selected as specified in this manual.
2. The drive is installed according to the instructions given in this manual.
3. The maximum motor cable length specification has not been exceeded.

This product can cause radio-frequency interference. In a residential or domestic environment, supplementary mitigation measures may be required in addition to the requirements listed above for the CE compliance.



WARNING!

You can install a drive with the internal EMC filter connected only on a symmetrically grounded TN-S system.

■ Category C3

This is applicable to ACS180-04S-...-4 drives with an internal EMC C3 filter.

The drive complies with the standard with the following provisions:

1. The motor and control cables are selected as specified in this manual.
 2. The drive is installed according to the instructions given in this manual.
 3. The maximum motor cable length specification has not been exceeded.
-



WARNING!

To prevent radio-frequency interference, do not use a category C3 drive on a low-voltage public network which supplies domestic premises.



WARNING!

You can install a drive with the internal EMC filter connected only on a symmetrically grounded TN-S system.

■ Category C4

This is applicable to ACS180-04N-...-1/4 and ACS180-04S-...-2 drives.

If the provisions in Category C2 or C3 are not met, the requirements of the standard can be met as follows:

1. It is ensured that no excessive emission is propagated to neighboring low-voltage networks. In some cases, the inherent suppression in transformers and cables is sufficient. If in doubt, the supply transformer with static screening between the primary and secondary windings can be used.
-

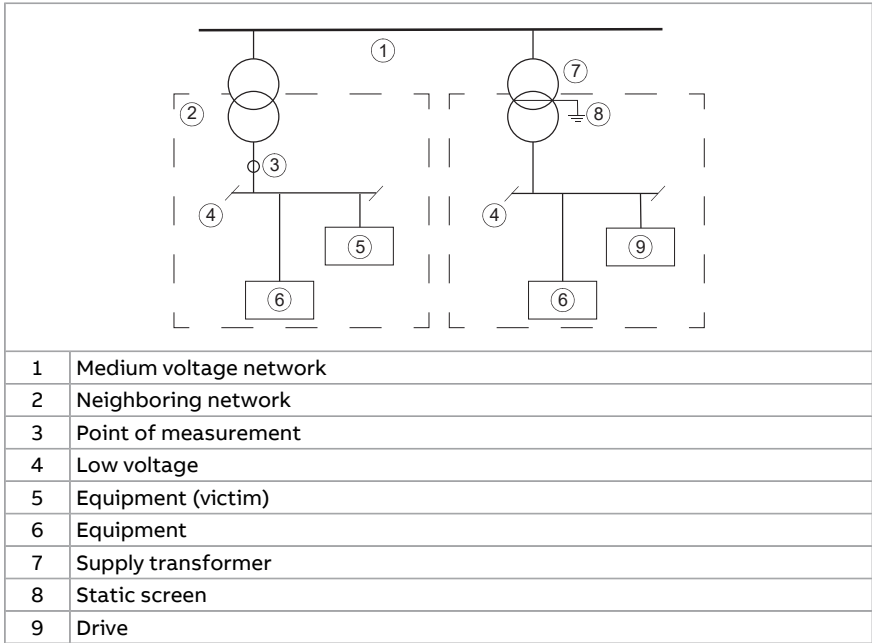

2. An EMC plan for preventing disturbances is drawn up for the installation. A template is available from the local ABB representative.
3. The motor and control cables are selected as specified in this manual.
4. The drive is installed according to the instructions given in this manual.

WARNING! To prevent radio-frequency interference, do not use a category C4 drive on a low-voltage public network which supplies domestic premises.

WARNING! You can install a drive with the internal EMC filter connected only on a symmetrically grounded TN-S system.

UL checklist

**WARNING!**

Operation of this drive requires detailed installation and operation instructions provided in the hardware and software manuals. The manuals are provided in electronic format in the drive package or on the Internet. Keep the manuals with the drive at all times. Hard copies of the manuals can be ordered through the manufacturer.

- Make sure that the drive type designation label includes the applicable marking.
 - **DANGER - Risk of electric shock.** After disconnecting the input power, always wait for 5 minutes to let the intermediate circuit capacitors discharge before you start working on the drive, motor or motor cable.
 - The drive is to be used in a heated, indoor controlled environment. The drive must be installed in clean air according to the enclosure classification. Cooling air must be clean, free from corrosive materials and electrically conductive dust.
 - The maximum surrounding air temperature is 50 °C at rated output current.
 - The drive is suitable for use in a circuit capable of delivering not more than 100000 rms symmetrical amperes, 480 V maximum (480 V drive types) or 240 V maximum (240 V drive types) when protected by the UL fuses given elsewhere in this chapter. The drive is also suitable for use on a circuit capable of delivering not more than 65000 rms symmetrical amperes at these maximum voltages when protected by the specific UL Type E combination motor controllers given elsewhere in this chapter, provided the drive is mounted within an enclosure of adequate minimum volume, and the assembly complies with all applicable footnotes of the Type E protection table. The ampere ratings of the protections are based on fault tests done according to the appropriate UL standard.
 - The cables located within the motor circuit must be rated for at least 75 °C in UL-compliant installations.
 - The input cable must be protected with UL-rated fuses listed in this manual. The fuses provide branch circuit protection in accordance with the National Electrical Code (NEC). Obey also any other applicable local or provincial codes.
-

**WARNING!**

The opening of the branch-circuit protective device may be an indication that a fault current has been interrupted. To reduce the risk of fire or electric shock, current-carrying parts and other components of the device should be examined and replaced if damaged.

- The drive provides motor overload protection. For adjustments, see the firmware manual.
-

- To maintain the environment integrity of the enclosure, replace the cable grommets with field-installed industrial conduit hubs or closure plates required by the enclosure type (or better).

Compliance with the European Machinery Directive

The drive includes the Safe torque off function and can be equipped with other safety functions for machinery which, as safety components, are in the scope of the Machinery Directive. These functions of the drive comply with European harmonized standards such as EN 61800-5-2. Refer to [The Safe torque off function \(page 143\)](#).

Disclaimers

■ Generic disclaimer

The manufacturer shall have no obligation with respect to any product which (i) has been improperly repaired or altered; (ii) has been subjected to misuse, negligence or accident; (iii) has been used in a manner contrary to the manufacturer's instructions; or (iv) has failed as a result of ordinary wear and tear.

■ Cybersecurity disclaimer

This product can be connected to and communicate information and data via a network interface. The HTTP protocol, which is used between the commissioning tool (Drive Composer) and the product, is an unsecured protocol. For independent and continuous operation of product such connection via network to commissioning tool is not necessary. However it is Customer's sole responsibility to provide and continuously ensure a secure connection between the product and Customer network or any other network (as the case may be). Customer shall establish and maintain any appropriate measures (such as but not limited to the installation of firewalls, prevention of physical access, application of authentication measures, encryption of data, installation of anti-virus programs, etc.) to protect the product, the network, its system and the interface against any kind of security breaches, unauthorized access, interference, intrusion, leakage and/or theft of data or information.

Notwithstanding any other provision to the contrary and regardless of whether the contract is terminated or not, ABB and its affiliates are under no circumstances liable for damages and/or losses related to such security breaches, any unauthorized access, interference, intrusion, leakage and/or theft of data or information.

10

Dimension drawings

Contents of this chapter

The chapter contains the dimension drawings of the drive. The dimensions are in millimeters and inches.

Frame R0

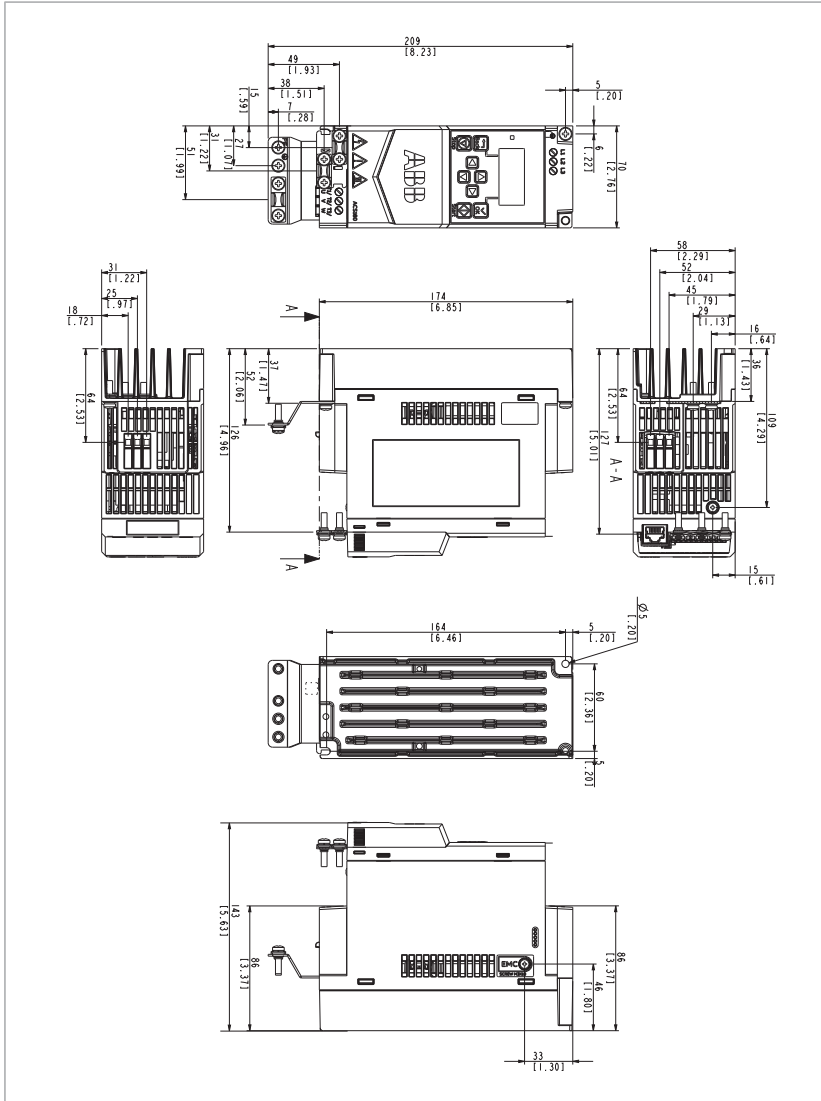

Frame R1

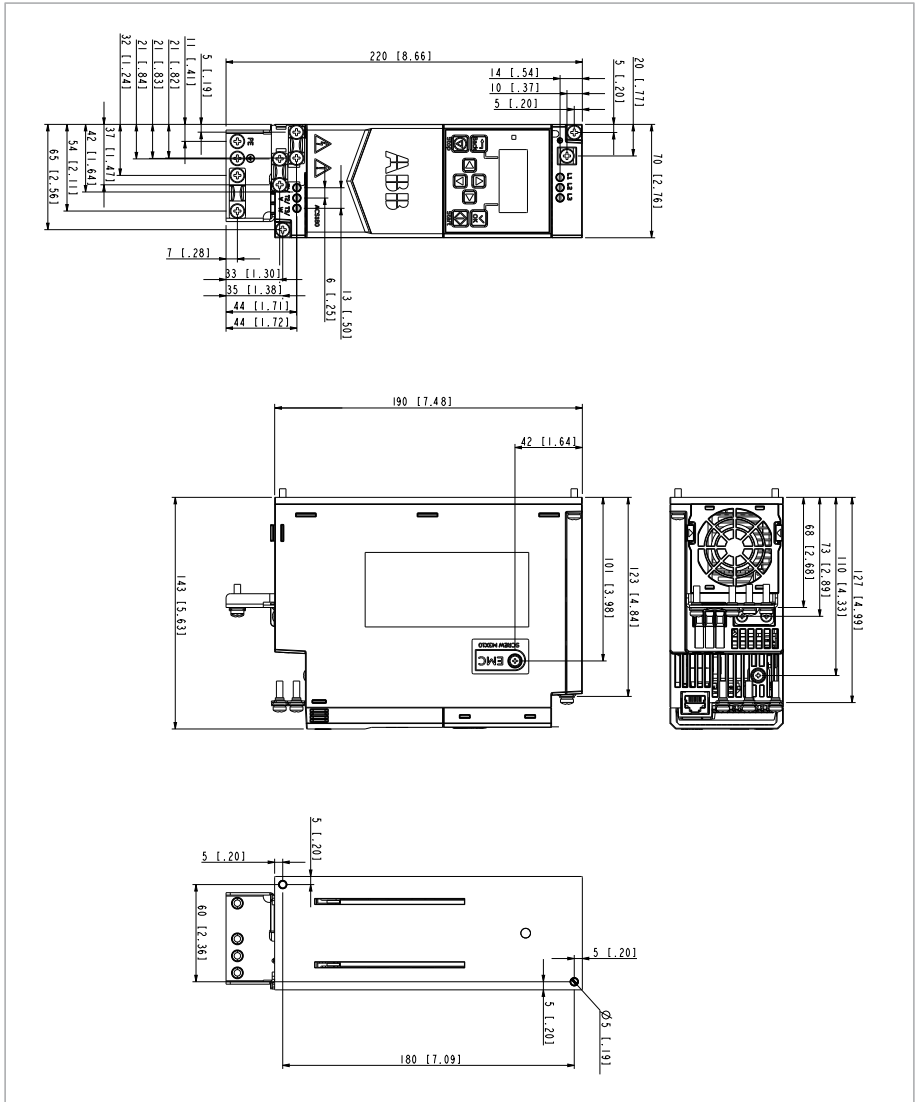

Frame R2

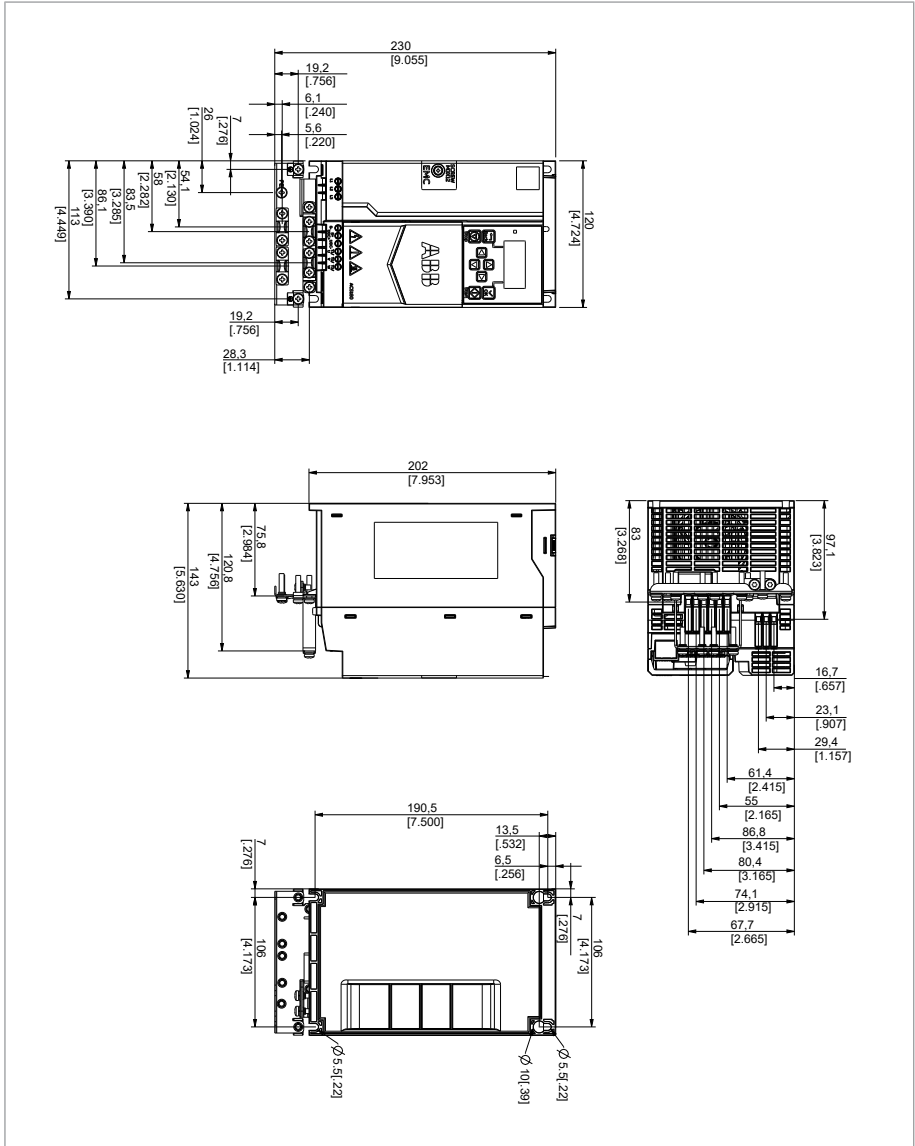

Frame R3

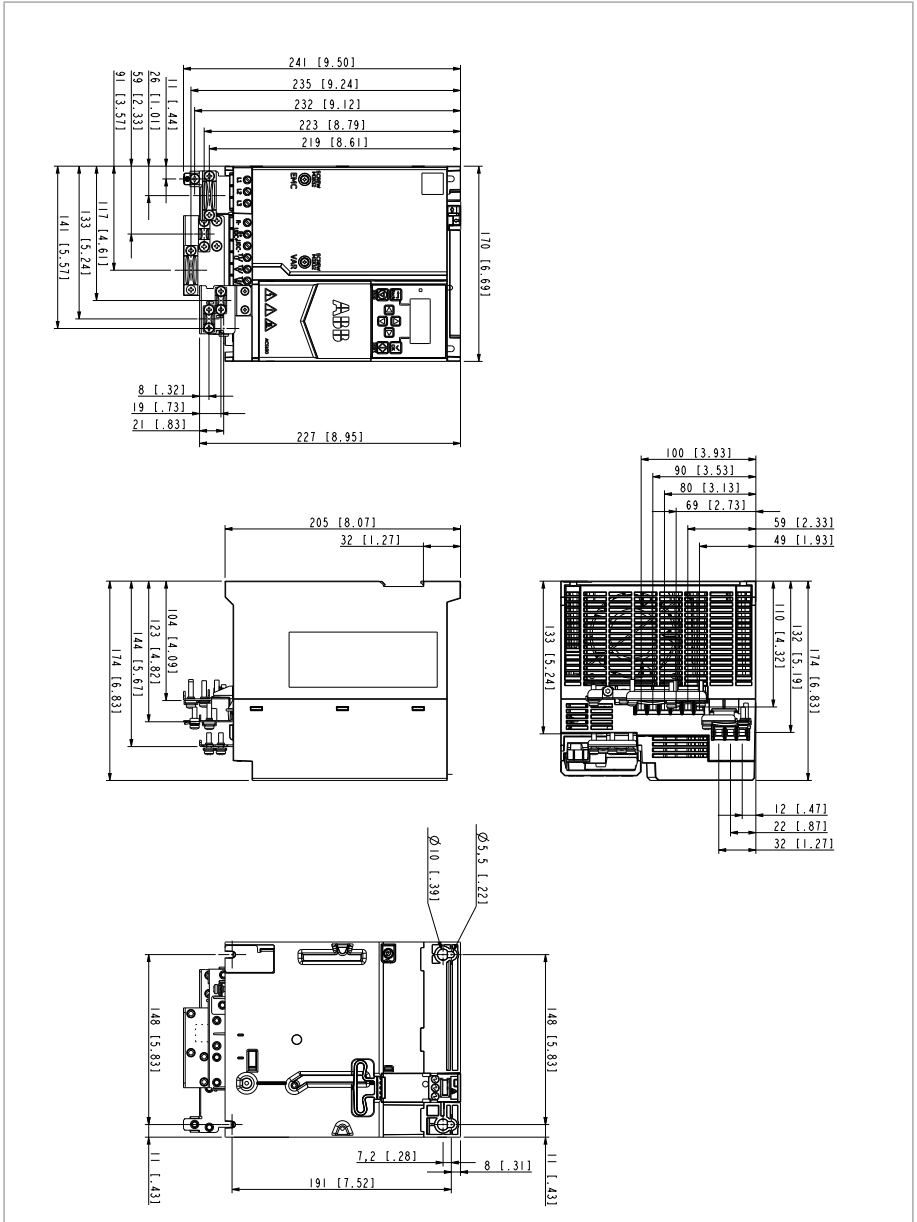

Frame R4

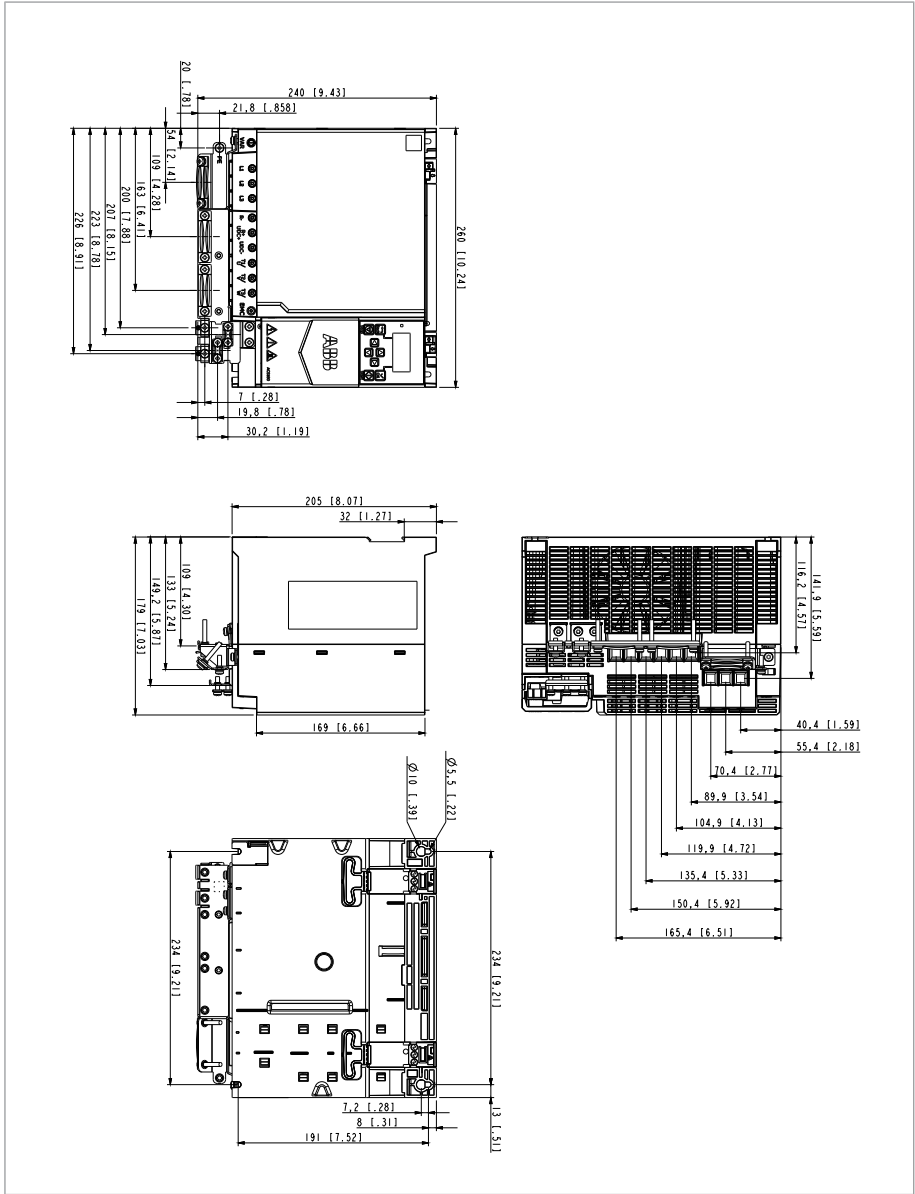

11

Resistor braking

Contents of this chapter

The chapter describes how to select the brake resistor and cables, protect the system, connect the brake resistor and enable resistor braking.

Safety

**WARNING!**

Do not do work on the brake resistor or the resistor cable when the drive is energized. A dangerous voltage is present in the resistor circuit, even when the brake chopper is not operating, or when it is disabled by a parameter.

Operation principle

The brake chopper handles the energy generated by a decelerating motor. The extra energy increases the DC link voltage. The chopper connects the brake resistor to the intermediate DC circuit whenever the voltage in the circuit exceeds the limit defined by the control program. Energy consumption by the resistor losses lowers the voltage until the resistor can be disconnected.

Selecting the brake resistor

Drives have a built-in brake chopper as standard equipment. The brake resistor is selected using the table and equations shown in this section.

1. Determine the required maximum braking power $P_{R_{max}}$ for the application. $P_{R_{max}}$ must be smaller than $P_{BR_{max}}$. Refer to [Reference brake resistors \(page 137\)](#).
 2. Calculate resistance R with Equation 1.
-

136 Resistor braking

3. Calculate energy E_{Rpulse} with Equation 2.
4. Select the resistor so that the following conditions are met:
 - The rated power of the resistor must be greater than or equal to P_{Rmax} .
 - Resistance R must be between R_{min} and R_{max} given in the table for the used drive type.
 - The resistor must be able to dissipate energy E_{Rpulse} during the braking cycle T .

Equations for selecting the resistor:

Equation 1

When the drive supply voltage is 200 ... 240 V:

$$R = \frac{150\,000}{P_{Rmax}}$$

When the drive supply voltage is 380 ... 415 V:

$$R = \frac{450\,000}{P_{Rmax}}$$

When the drive supply voltage is 415 ... 480 V:

$$R = \frac{615\,000}{P_{Rmax}}$$

Equation 2

$$E_{Rpulse} = P_{Rmax} \cdot t_{on}$$

Equation 3

$$P_{Rave} = P_{Rmax} \cdot \frac{t_{on}}{T}$$

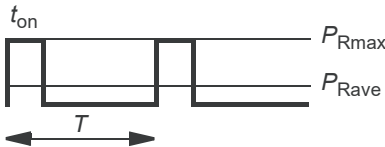

For conversion, use 1 hp = 746 W.

R	Calculated brake resistor value (ohm). Make sure that: $R_{min} < R < R_{max}$
P_{Rmax}	Maximum power during the braking cycle (W)
P_{Rave}	Average power during the braking cycle (W)
E_{Rpulse}	Energy conducted into the resistor during a single braking pulse (J)
t_{on}	Braking time (one cycle) (s)
T	Braking cycle time (s)

**WARNING!**

Do not use a brake resistor with a resistance below the minimum value specified for the particular drive. The drive and the internal chopper are not able to handle the overcurrent caused by the low resistance.

■ Reference brake resistors

ACS180-04...1)	R_{min}	R_{max}	P_{BRcont}		P_{BRmax}		Example resistor types ^{2) 3)}
	ohm	ohm	kW	hp	kW	hp	Danotherm
1-phase $U_n = 200...240$ V							
12A2-1	19.5	47.1	2.2	3	3.3	4.4	CBR-V 560 D HT 406 39R UL
3-phase $U_n = 200...240$ V							
15A6-2	19.5	51.9	2.2	3	3.3	4.4	CBR-V 560 D HT 406 39R UL
17A5-2	15.6	38.5	3	3	4.5	6	CBT-H 560 D HT 406 19R
25A0-2	14	28	4	5	6	8	
033A-2	12	20	5.5	7.5	8.3	11	
048A-2	3	14	7.5	10	11.3	15	CBT-V 760 G HT 282 8R
055A-2	3	10	11	15	16.5	22	
3-phase $U_n = 380...415$ V							
12A6-4	31.6	75.7	4	5	6	8	CBR-V 330 D T 406 78R UL
17A0-4	31.6	54.4	5.5	7.5	8.3	11	CBR-V 560 D HT 406 39R UL
25A0-4	37	49	7.5	10	11.3	15	
033A-4	24	33	11	15	16.5	22	CBT-H 560 D HT 406 19R
038A-4	6	23.7	15	20	22.5	30	
045A-4	6	19.7	18.5	25	27.8	37	CBT-H 760 D HT 406 16R
050A-4	6	19.7	22	30	33	44	

1) Frame size R0/R1 doesn't support brake resistor.

2) Braking cycle differs from that of the drive. Refer to brake resistor manufacturer's documentation.

3) If brake resistors from other manufacturers are used, the characteristics must agree with the values in the table.

Definitions

P_{BRmax} The maximum braking capacity of the drive, when the length of the braking pulse is at most 1 minute for each 10 minutes ($P_{BRcont} \times 1.5$). Must be more than the desired braking power.

P_{BRcont} The continuous braking capacity of the drive

R_{max} The maximum resistance value of the brake resistor that can provide P_{BRcont}

R_{\min} The minimum permitted resistance value of the brake resistor

Selecting and routing the brake resistor cables

Use a shielded cable specified in the technical data.

■ Minimizing electromagnetic interference

Obey these rules in order to minimize electromagnetic interference caused by the rapid current changes in the resistor cables:

- Shield the braking power line completely, either by using shielded cable or a metallic enclosure. Unshielded single-core cable can only be used if it is routed inside a cabinet that efficiently suppresses the radiated emissions.
- Install the cables away from other cable routes.
- Avoid long parallel runs with other cables. The minimum parallel cabling separation distance is 0.3 meters (1 ft).
- Cross the other cables at 90 degree angles.
- Keep the cable as short as possible in order to minimize the radiated emissions and stress on chopper IGBTs. The longer the cable the greater the radiated emissions, inductive load and voltage peaks over the IGBT semiconductors of the brake chopper.

Note: ABB has not verified that the EMC requirements are fulfilled with custom brake resistors and cabling. The customer must consider the EMC compliance of the complete installation.

■ Maximum cable length

The maximum length of the resistor cable(s) is 10 m (33 ft).

Placing the brake resistors

Install the resistor assembly outside the drive in a place where it is able to cool effectively.

Arrange the cooling of the resistor so that:

- no danger of overheating is caused to the resistor or nearby materials, and
- the temperature of the room the resistor is located in does not exceed the allowed maximum.

Supply the resistor with cooling air or coolant according to the resistor manufacturer's instructions.

**WARNING!**

The materials near the brake resistor must be non-flammable. The surface temperature of the resistor is high. Air flowing from the resistor is of hundreds of degrees Celsius. If the exhaust vents are connected to a ventilation system, make sure that the material withstands high temperatures. Protect the resistor against contact.

Protecting the system in brake circuit fault situations

■ Protecting the system in cable and brake resistor short-circuit situations

The drive input fuses will also protect the resistor cable when it is identical with the input power cable.

■ Protecting the system against thermal overload

The drive has a brake thermal model which protects the brake resistor against overload. ABB recommends to enable the thermal model at start up.

ABB recommends to equip the drive with a main contactor for safety reasons even when you have enabled the resistor thermal model. Wire the contactor so that it opens in case the resistor overheats. This is essential for safety since the drive will not otherwise be able to interrupt the main supply if the chopper remains conductive in a fault situation. An example wiring diagram is shown below. ABB recommends that you use resistors equipped with a thermal switch (1) inside the resistor assembly. The switch indicates overtemperature.

140 Resistor braking

ABB recommends that you also wire the thermal switch to a digital input of the drive, and configure the input to cause a fault trip at resistor overtemperature indication.

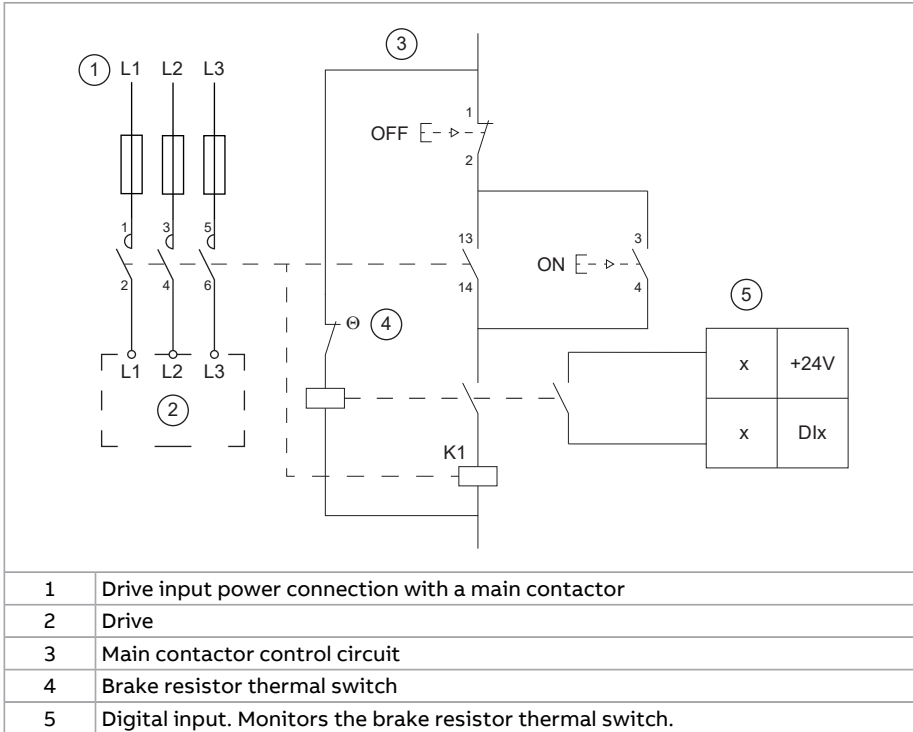

Mechanical and electrical installation of brake resistor



WARNING!

Obey the safety instructions of the drive. If you ignore them, injury or death, or damage to the equipment can occur. If you are not a qualified electrical professional, do not do installation, commissioning or maintenance work.



WARNING!

Stop the drive and do the steps in section [Electrical safety precautions](#) (page 16) before you start the work.

■ Mechanical installation

Refer to the resistor manufacturer's instructions.

■ Electrical installation

Measuring the insulation

See the electrical installation instructions of the drive.

Connecting power cables

See the electrical installation instructions of the drive.

Connection the control cables

Connect the thermal switch of the brake resistor as described in [Protecting the system against thermal overload \(page 139\)](#).

Start-up

Set the following parameters:

1. Disable the overvoltage control of the drive with parameter *30.30 Overvoltage control*.
2. Set the source of parameter *31.01 External event 1 source* to point to the digital input where the thermal switch of the brake resistor is wired.
3. Set parameter *31.02 External event 1 type* to *Fault*.
4. Enable the brake chopper by parameter *43.06 Brake chopper enable*. If *Enabled with thermal model* is selected, set also the brake resistor overload protection parameters *43.08* and *43.09* according to the application.
5. Check the resistance value of parameter *43.10 Brake resistance*.

With these parameter settings, the drive generates a fault and coasts to a stop on brake resistor overtemperature.

12

The Safe torque off function

Contents of this chapter

This chapter describes the Safe torque off (STO) function of the drive and gives instructions for its use.

Description

The Safe torque off function can be used, for example, as the final actuator device of safety circuits (such as an emergency stop circuit) that stop the drive in case of danger. Another typical application is a prevention of unexpected start-up function that enables short-time maintenance operations like cleaning or work on non-electrical parts of the machinery without switching off the power supply to the drive.

When activated, the Safe torque off function disables the control voltage for the power semiconductors of the drive output stage, thus preventing the drive from generating the torque required to rotate the motor. If the motor is running when Safe torque off is activated, it coasts to a stop.

The Safe torque off function has a redundant architecture, that is, both channels must be used in the safety function implementation. The safety data given in this manual is calculated for redundant use, and does not apply if both channels are not used.

The Safe torque off function complies with these standards:

Standard	Name
IEC 60204-1:2016 EN 60204-1:2018	Safety of machinery – Electrical equipment of machines – Part 1: General requirements

Standard	Name
IEC 61000-6-7:2014	Electromagnetic compatibility (EMC) – Part 6-7: Generic standards – Immunity requirements for equipment intended to perform functions in a safety-related system (functional safety) in industrial locations
IEC 61326-3-1:2017	Electrical equipment for measurement, control and laboratory use – EMC requirements – Part 3-1: Immunity requirements for safety-related systems and for equipment intended to perform safety-related functions (functional safety) – General industrial applications
IEC 61508-1:2010	Functional safety of electrical/electronic/programmable electronic safety-related systems – Part 1: General requirements
IEC 61508-2:2010	Functional safety of electrical/electronic/programmable electronic safety-related systems – Part 2: Requirements for electrical/electronic/programmable electronic safety-related systems
IEC 61511-1:2017	Functional safety – Safety instrumented systems for the process industry sector
IEC 61800-5-2:2016 EN 61800-5-2:2007	Adjustable speed electrical power drive systems – Part 5-2: Safety requirements – Functional
IEC 62061:2021 EN 62061:2021	Safety of machinery – Functional safety of safety-related electrical, electronic and programmable electronic control systems
EN ISO 13849-1:2015	Safety of machinery – Safety-related parts of control systems – Part 1: General principles for design
EN ISO 13849-2:2012	Safety of machinery – Safety-related parts of control systems – Part 2: Validation

The function also corresponds to Prevention of unexpected start-up as specified by EN ISO 14118:2018 (ISO 14118:2017), and Uncontrolled stop (stop category 0) as specified in EN/IEC 60204-1.

■ **Compliance with the European Machinery Directive and the UK Supply of Machinery (Safety) Regulations**

The Declarations of conformity are shown at the end of this chapter.

Wiring

For the electrical specifications of the STO connection, see the technical data of the control unit.

■ Connection principle

Single ACS180 drive, internal power supply

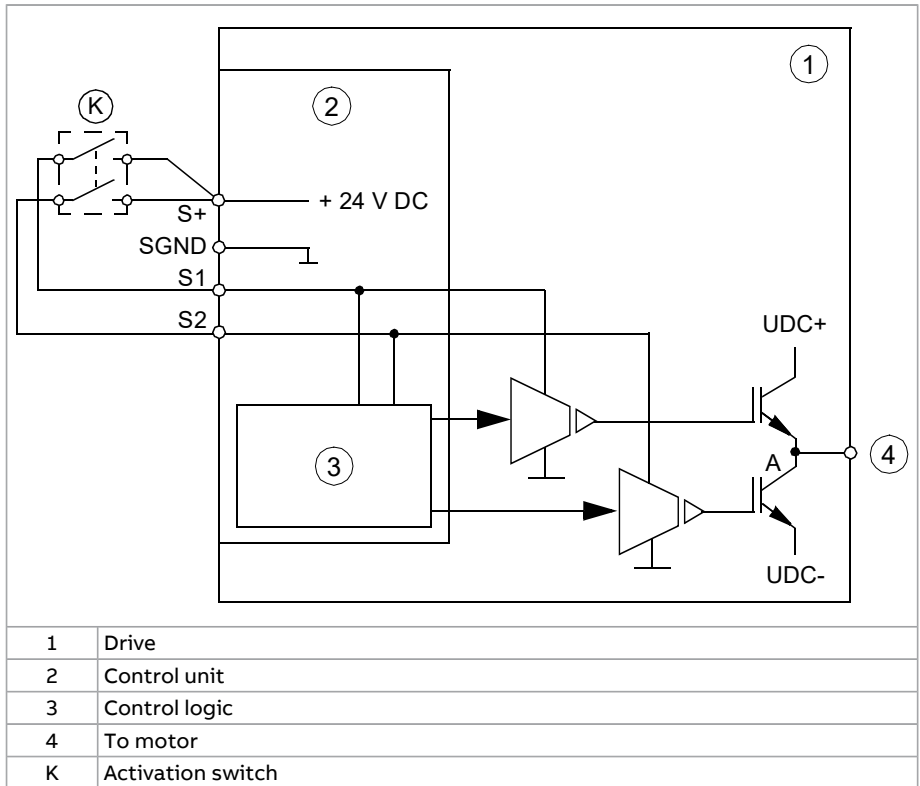

Single ACS180 drive, external power supply

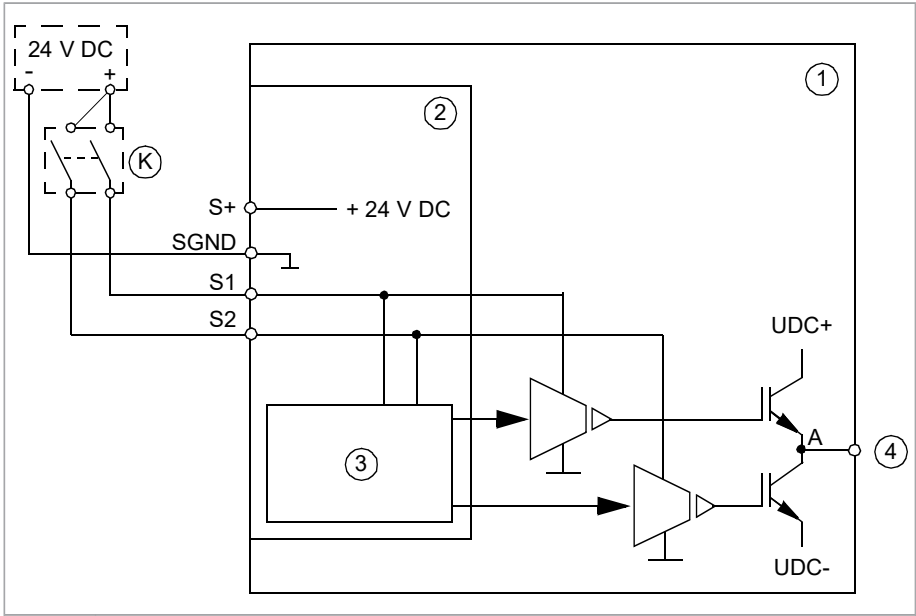

1	Drive
2	Control unit
3	Control logic
4	To motor
K	Activation switch

■ Wiring examples

Single ACS180 drive, internal power supply

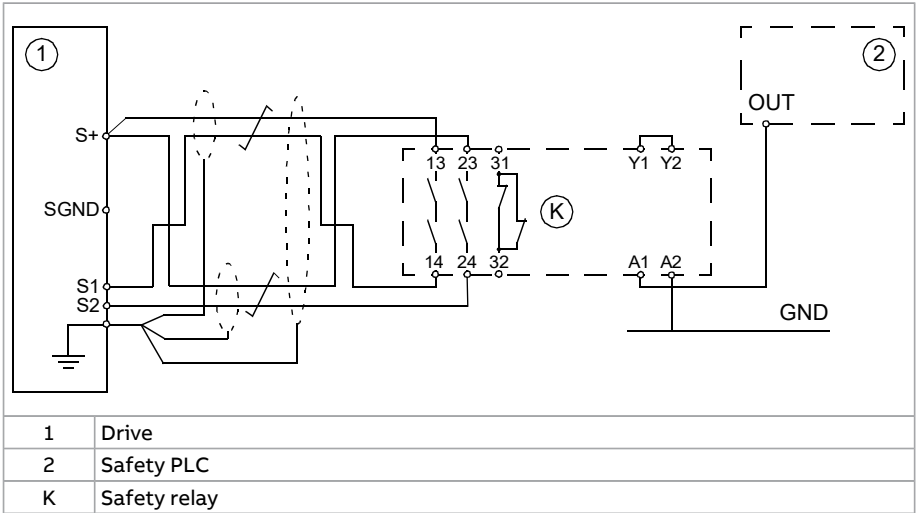

Single ACS180 drive, external power supply

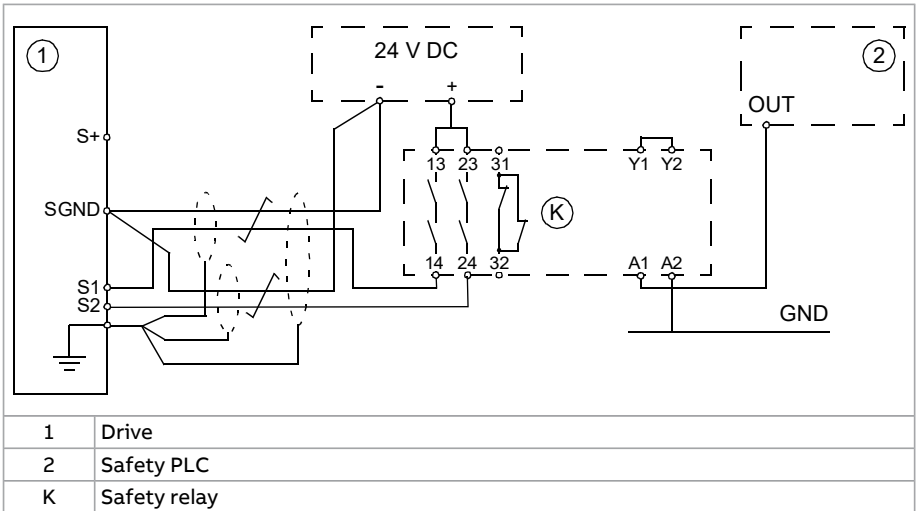

Multiple ACS180 drives, internal power supply

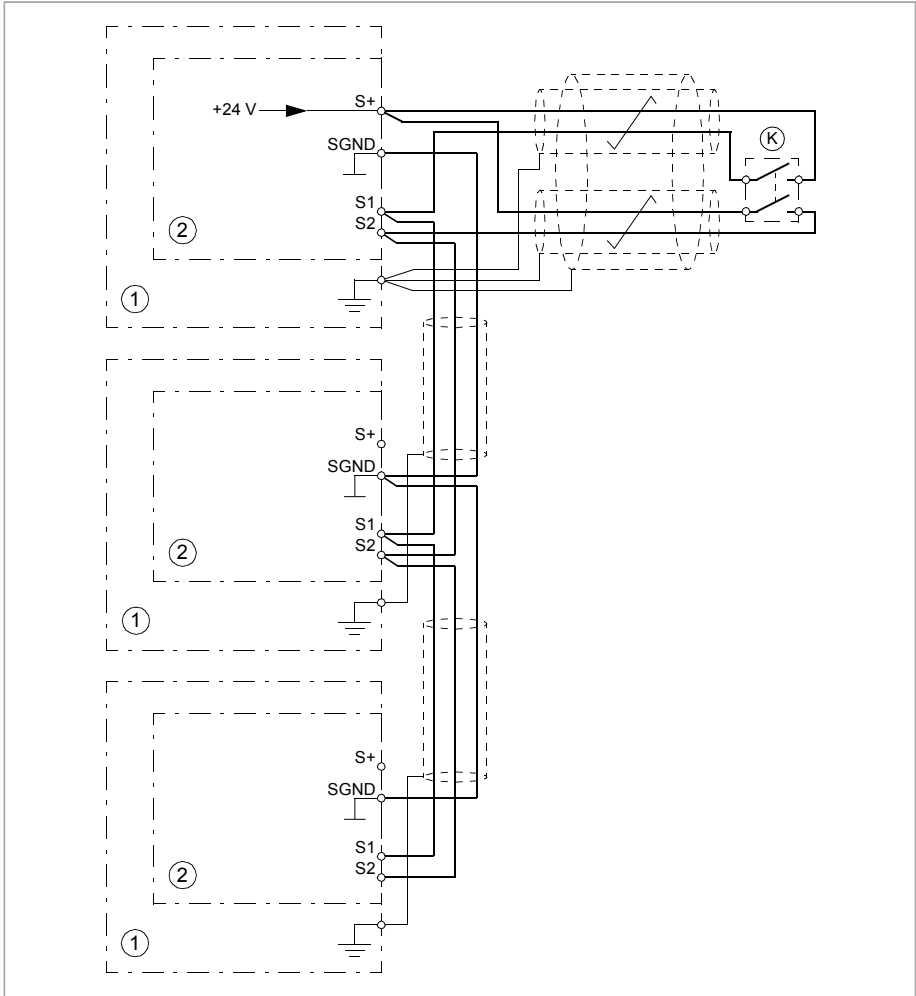

1	Drive
2	Control unit
K	Activation switch

Multiple ACS180 drives, external power supply

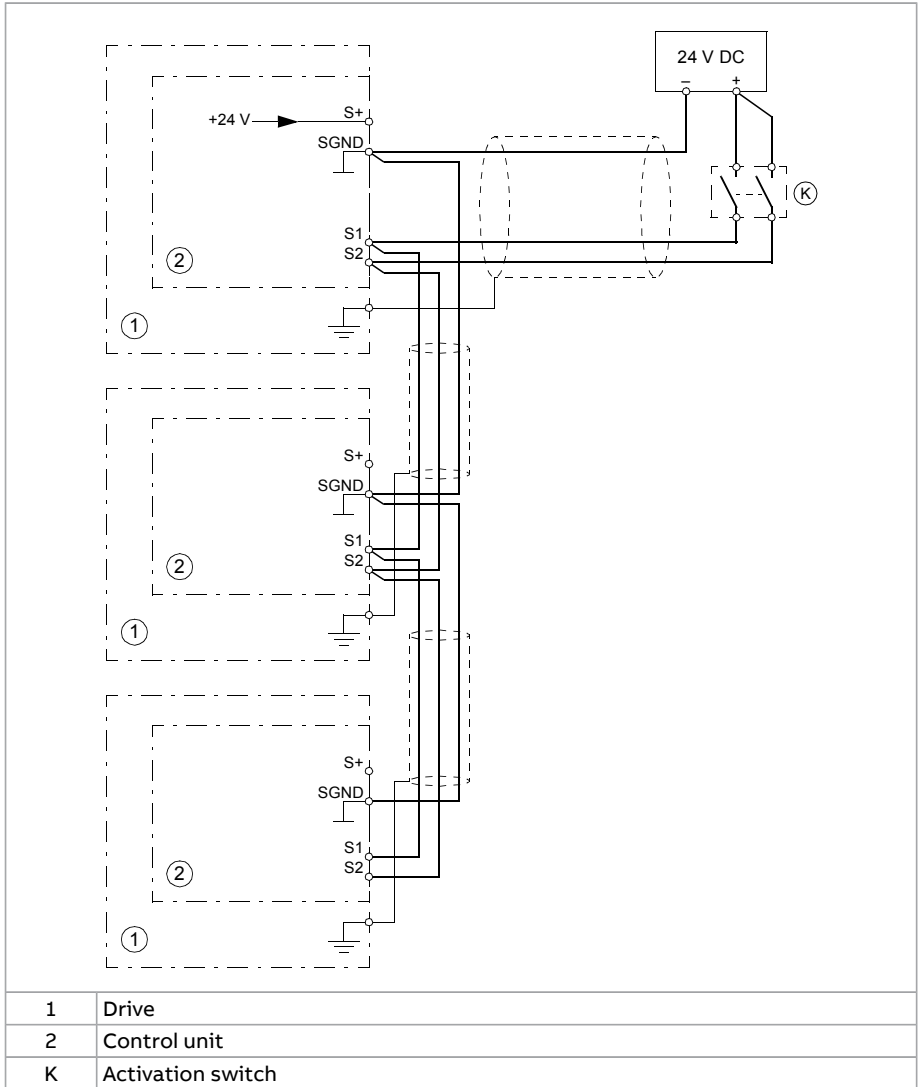

■ **Activation switch**

In the wiring diagrams, the activation switch has the designation [K]. This represents a component such as a manually operated switch, an emergency stop push button switch, or the contacts of a safety relay or safety PLC.

150 The Safe torque off function

- In case a manually operated activation switch is used, the switch must be of a type that can be locked out to the open position.
- The contacts of the switch or relay must open/close within 200 ms of each other.

■ Cable types and lengths

- ABB recommends double-shielded twisted-pair cable.
- Maximum cable lengths:
 - 300 m (1000 ft) between activation switch [K] and drive control unit
 - 60 m (200 ft) between multiple drives
 - 60 m (200 ft) between external power supply and first control unit

Note: A short-circuit in the wiring between the switch and an STO terminal causes a dangerous fault. Therefore, it is recommended to use a safety relay (including wiring diagnostics) or a wiring method (shield grounding, channel separation) which reduces or eliminates the risk caused by the short-circuit.

Note: The voltage at the STO input terminals of the drive must be at least 13 V DC to be interpreted as “1”.

The pulse tolerance of the input channels is 1 ms.

■ Grounding of protective shields

- Ground the shield in the cabling between the activation switch and the control unit at the control unit only.
 - Ground the shield in the cabling between two control units at one control unit only.
-

Operation principle

1. The Safe torque off activates (the activation switch is opened, or safety relay contacts open).
2. The STO inputs of the drive control unit de-energize.
3. The control unit cuts off the control voltage from the output IGBTs.
4. The control program generates an indication as defined by parameter 31.22 (see the firmware manual of the drive).

The parameter selects which indications are given when one or both STO signals are switched off or lost. The indications also depend on whether the drive is running or stopped when this occurs.

Note: This parameter does not affect the operation of the STO function itself. The STO function will operate regardless of the setting of this parameter: a running drive will stop upon removal of one or both STO signals, and will not start until both STO signals are restored and all faults reset.

Note: The loss of only one STO signal always generates a fault as it is interpreted as a malfunction of STO hardware or wiring.

5. The motor coasts to a stop (if running). The drive cannot restart while the activation switch or safety relay contacts are open. After the contacts close, a reset may be needed (depending on the setting of parameter 31.22). A new start command is required to start the drive.
-

Start-up including validation test

To ensure the safe operation of a safety function, validation is required. The final assembler of the machine must validate the function by performing a validation test. The test must be performed

1. at initial start-up of the safety function
2. after any changes related to the safety function (circuit boards, wiring, components, settings, replacement of inverter module, etc.)
3. after any maintenance work related to the safety function
4. after a drive firmware update
5. at the proof test of the safety function.

■ Competence

The validation test of the safety function must be carried out by a competent person with adequate expertise and knowledge of the safety function as well as functional safety, as required by IEC 61508-1 clause 6. The test procedures and report must be documented and signed by this person.

■ Validation test reports

Signed validation test reports must be stored in the logbook of the machine. The report shall include documentation of start-up activities and test results, references to failure reports and resolution of failures. Any new validation tests performed due to changes or maintenance shall be logged into the logbook.

■ Validation test procedure

After wiring the Safe torque off function, validate its operation as follows.

Action	<input checked="" type="checkbox"/>
 WARNING! Obey the safety instructions. If you ignore them, injury or death, or damage to the equipment can occur.	<input type="checkbox"/>
Make sure that the motor can be run and stopped freely during start-up.	<input type="checkbox"/>
Stop the drive (if running), switch the input power off and isolate the drive from the power line using a disconnecter.	<input type="checkbox"/>
Check the STO circuit connections against the wiring diagram.	<input type="checkbox"/>
Close the disconnecter and switch the power on.	<input type="checkbox"/>

Action	<input checked="" type="checkbox"/>
<p>Test the operation of the STO function when the motor is stopped.</p> <ul style="list-style-type: none"> • Give a stop command for the drive (if running) and wait until the motor shaft is at a standstill. <p>Make sure that the drive operates as follows:</p> <ul style="list-style-type: none"> • Open the STO circuit. The drive generates an indication if one is defined for the 'stopped' state in parameter 31.22 (see the firmware manual). • Give a start command to verify that the STO function blocks the drive's operation. The motor should not start. • Close the STO circuit. • Reset any active faults. Restart the drive and check that the motor runs normally. 	<input type="checkbox"/>
<p>Test the operation of the STO function when the motor is running.</p> <ul style="list-style-type: none"> • Start the drive and make sure the motor is running. • Open the STO circuit. The motor should stop. The drive generates an indication if one is defined for the 'running' state in parameter 31.22 (see the firmware manual). • Reset any active faults and try to start the drive. • Make sure that the motor stays at a standstill and the drive operates as described above in testing the operation when the motor is stopped. • Close the STO circuit. • Reset any active faults. Restart the drive and check that the motor runs normally. 	<input type="checkbox"/>
<p>Test the operation of the failure detection of the drive. The motor can be stopped or running.</p> <ul style="list-style-type: none"> • Open the 1st input channel of the STO circuit. If the motor was running, it should coast to a stop. The drive generates an FA81 fault indication (see the firmware manual). • Give a start command to verify that the STO function blocks the drive's operation. The motor should not start. • Close the STO circuit. • Reset any active faults. Restart the drive and check that the motor runs normally. • Open the 2nd input channel of the STO circuit. If the motor was running, it should coast to a stop. The drive generates an FA82 fault indication (see the firmware manual). • Give a start command to verify that the STO function blocks the drive's operation. The motor should not start. • Close the STO circuit. • Reset any active faults. Restart the drive and check that the motor runs normally. 	<input type="checkbox"/>
<p>Document and sign the validation test report which verifies that the safety function is safe and accepted for operation.</p>	<input type="checkbox"/>

Use

1. Open the activation switch, or activate the safety functionality that is wired to the STO connection.
2. The STO inputs on the drive control unit de-energize, and the control unit cuts off the control voltage from the output IGBTs.
3. The control program generates an indication as defined by parameter 31.22 (see the firmware manual of the drive).
4. The motor coasts to a stop (if running). The drive will not restart while the activation switch or safety relay contacts are open.
5. Deactivate the STO by closing the activation switch, or resetting the safety functionality that is wired to the STO connection.
6. Reset any faults before restarting.



WARNING!

The Safe torque off function does not disconnect the voltage of the main and auxiliary circuits from the drive. Therefore maintenance work on electrical parts of the drive or the motor can only be carried out after isolating the drive from the supply and all other voltage sources.



WARNING!

The drive cannot detect or memorize any changes in the STO circuitry when the drive control unit is not powered. If both STO circuits are closed and a level-type start signal is active when the power is restored, it is possible that the drive starts without a fresh start command. Take this into account in the risk assessment of the system.



WARNING!

Permanent magnet or synchronous reluctance [SynRM] motors only:

In case of a multiple IGBT power semiconductor failure, the drive can produce an alignment torque which maximally rotates the motor shaft by $180/p$ degrees (with permanent magnet motors) or $180/2p$ degrees (with synchronous reluctance [SynRM] motors) regardless of the activation of the Safe torque off function. p denotes the number of pole pairs.

Notes:

- If a running drive is stopped by using the Safe torque off function, the drive will cut off the motor supply voltage and the motor will coast to a stop. If this causes danger or is not otherwise acceptable, stop the drive and machinery using the appropriate stop mode before activating the Safe torque off function.
 - The Safe torque off function overrides all other functions of the drive.
-

- The Safe torque off function is ineffective against deliberate sabotage or misuse.
- The Safe torque off function has been designed to reduce the recognized hazardous conditions. In spite of this, it is not always possible to eliminate all potential hazards. The assembler of the machine must inform the final user about the residual risks.

Maintenance

After the operation of the circuit is validated at start-up, the STO function shall be maintained by periodic proof testing. In high demand mode of operation, the maximum proof test interval is 20 years. In low demand mode of operation, the maximum proof test interval is 5 years; see section [Safety data \(page 158\)](#). It is assumed that all dangerous failures of the STO circuit are detected by the proof test. To perform the proof test, do the [Validation test procedure \(page 152\)](#).

Note: See also the Recommendation of Use CNB/M/11.050 (published by the European co-ordination of Notified Bodies) concerning dual-channel safety-related systems with electromechanical outputs:

- When the safety integrity requirement for the safety function is SIL 3 or PL e (cat. 3 or 4), the proof test for the function must be performed at least every month.
- When the safety integrity requirement for the safety function is SIL 2 (HFT = 1) or PL d (cat. 3), the proof test for the function must be performed at least every 12 months.

The STO function of the drive does not contain any electromechanical components.

In addition to proof testing, it is a good practice to check the operation of the function when other maintenance procedures are carried out on the machinery.

Include the Safe torque off operation test described above in the routine maintenance program of the machinery that the drive runs.

If any wiring or component change is needed after start-up, or the parameters are restored, do the test given in section [Validation test procedure \(page 152\)](#).

Use only spare parts approved by ABB.

Record all maintenance and proof test activities in the machine logbook.

■ Competence

The maintenance and proof test activities of the safety function must be carried out by a competent person with adequate expertise and knowledge of the safety function as well as functional safety, as required by IEC 61508-1 clause 6.

Fault tracing

The indications given during the normal operation of the Safe torque off function are selected by drive control program parameter 31.22.

The diagnostics of the Safe torque off function cross-compare the status of the two STO channels. In case the channels are not in the same state, a fault reaction function is performed and the drive trips on an FA81 or FA82 fault. An attempt to use the STO in a non-redundant manner, for example activating only one channel, will trigger the same reaction.

See the firmware manual of the drive control program for the indications generated by the drive, and for details on directing fault and warning indications to an output on the control unit for external diagnostics.

Any failures of the Safe torque off function must be reported to ABB.

Safety data

The safety data for the Safe torque off function is given below.

Note: The safety data is calculated for redundant use, and applies only if both STO channels are used.

Frame size	SIL	SC	PL	SFF (%)	PFH ($T_1 = 20$ a) (1/h)	PFDAvg ($T_1 = 2$ a)	PFDAvg ($T_1 = 5$ a)	MTTFD (a)	DC (%)	Cat.	HFT	CCF	T_M (a)	PFHdiag (1/h)	$\lambda_{diag,s}$ (1/h)	$\lambda_{diag,d}$ (1/h)
R0	3	3	e	>90	2.50E-10	2.23E-06	5.51E-06	6422	≥90	3	1	80	20	4.39E-08	65.93	43.90
R1	3	3	e	>90	1.41E-10	1.27E-06	3.12E-06	6461	≥90	3	1	80	20	4.39E-08	65.93	43.90
R2	3	3	e	>90	1.41E-10	1.27E-06	3.12E-06	6461	≥90	3	1	80	20	4.39E-08	65.93	43.90
R3	3	3	e	>90	1.41E-10	1.27E-06	3.12E-06	6461	≥90	3	1	80	20	4.39E-08	65.93	43.90
R4	3	3	e	>90	1.41E-10	1.27E-06	3.12E-06	6461	≥90	3	1	80	20	4.39E-08	65.93	43.90

3AXDI0000802392 E

160 The Safe torque off function

- The following temperature profile is used in safety value calculations:
 - 670 on/off cycles per year with $\Delta T = 71.66\text{ }^{\circ}\text{C}$
 - 1340 on/off cycles per year with $\Delta T = 61.66\text{ }^{\circ}\text{C}$
 - 30 on/off cycles per year with $\Delta T = 10.0\text{ }^{\circ}\text{C}$
 - 32 °C board temperature at 2.0% of time
 - 60 °C board temperature at 1.5% of time
 - 85 °C board temperature at 2.3% of time.
- The STO is a type A safety component as defined in IEC 61508-2.
- Relevant failure modes:
 - The STO trips spuriously (safe failure)
 - The STO does not activate when requested
 - A fault exclusion on the failure mode “short circuit on printed circuit board” has been made (EN 13849-2, table D.5). The analysis is based on an assumption that one failure occurs at one time. No accumulated failures have been analyzed.
- STO response times:
 - STO reaction time (shortest detectable break): 1 ms
 - STO response time: 5 ms (typical), 10 ms (maximum)
 - Fault detection time: Channels in different states for longer than 200 ms
 - Fault reaction time: Fault detection time + 10 ms.
- Indication delays:
 - STO fault indication (parameter 31.22) delay: < 500 ms
 - STO warning indication (parameter 31.22) delay: < 1000 ms.

■ Terms and abbreviations

Term or abbreviation	Reference	Description
Cat.	EN ISO 13849-1	Classification of the safety-related parts of a control system in respect of their resistance to faults and their subsequent behavior in the fault condition, and which is achieved by the structural arrangement of the parts, fault detection and/or by their reliability. The categories are: B, 1, 2, 3 and 4.
CCF	EN ISO 13849-1	Common cause failure (%)
DC	EN ISO 13849-1	Diagnostic coverage (%)
HFT	IEC 61508	Hardware fault tolerance
MTTF _D	EN ISO 13849-1	Mean time to dangerous failure: (Total number of life units) / (Number of dangerous, undetected failures) during a particular measurement interval under stated conditions

Term or abbreviation	Reference	Description
PFD _{avg}	IEC 61508	Average probability of dangerous failure on demand, that is, mean unavailability of a safety-related system to perform the specified safety function when a demand occurs
PFH	IEC 61508	Average frequency of dangerous failures per hour, that is, average frequency of a dangerous failure of a safety related system to perform the specified safety function over a given period of time
PL	EN ISO 13849-1	Performance level. Levels a...e correspond to SIL
Proof test	IEC 61508, IEC 62061	Periodic test performed to detect failures in a safety-related system so that, if necessary, a repair can restore the system to an "as new" condition or as close as practical to this condition
SC	IEC 61508	Systematic capability (1...3)
SFF	IEC 61508	Safe failure fraction (%)
SIL	IEC 61508	Safety integrity level (1...3)
STO	IEC/EN 61800-5-2	Safe torque off
T_1	IEC 61508-6	Proof test interval. T_1 is a parameter used to define the probabilistic failure rate (PFH or PFD) for the safety function or subsystem. Performing a proof test at a maximum interval of T_1 is required to keep the SIL capability valid. The same interval must be followed to keep the PL capability (EN ISO 13849) valid. See also section Maintenance.
T_M	EN ISO 13849-1	Mission time: the period of time covering the intended use of the safety function/device. After the mission time elapses, the safety device must be replaced. Note that any T_M values given cannot be regarded as a guarantee or warranty.

■ TÜV certificate

The TÜV certificate is available on the Internet at www.abb.com/drives/documents.

■ **Declarations of conformity**



EU Declaration of Conformity

Machinery Directive 2006/42/EC

We

Manufacturer: ABB Beijing Drive Systems Co., Ltd.

Address: No.1, Block D, A-10 Jiuxianqiao Beilu, Chaoyang District, Beijing 100015, P.R. China.

Phone: +86 010 58217788

declare under our sole responsibility that the following products:

Frequency converters

- ACS180-04S-xxAx-1 (Frame R0, 1ph 200-240Vac)
- ACS180-04S-xxAx-2 (Frame R0, 3ph 200-240Vac)
- ACS180-04S-xxAx-4 (Frame R0, 3ph 380-480Vac)
- ACS180-04S-xxAx-1 (Frame R1, 1ph 200-240Vac)
- ACS180-04S-xxAx-2 (Frame R1, 3ph 200-240Vac)
- ACS180-04S-xxAx-4 (Frame R1, 3ph 380-480Vac)
- ACS180-04S-xxAx-1 (Frame R2, 1ph 200-240Vac)
- ACS180-04S-xxAx-2 (Frame R2, 3ph 200-240Vac)
- ACS180-04S-xxAx-4 (Frame R2, 3ph 380-480Vac)
- ACS180-04S-xxAx-2 (Frame R3, 3ph 200-240Vac)
- ACS180-04S-xxAx-4 (Frame R3, 3ph 380-480Vac)
- ACS180-04S-xxxA-2 (Frame R4, 3ph 200-240Vac)
- ACS180-04S-xxxA-4 (Frame R4, 3ph 380-480Vac)

with regard to the safety function

Safe torque-off

are in conformity with all the relevant safety component requirements of the EU Machinery Directive 2006/42/EC, when the listed safety function is used for safety component functionality.

The following harmonized standards have been applied:

EN 61800-5-2:2007	Adjustable speed electrical power drive systems – Part 5-2: Safety requirements - Functional
EN 62061:2005 + AC:2010 + A1:2013 + A2:2015	Safety of machinery – Functional safety of safety-related electrical, electronic and programmable electronic control systems
EN ISO 13849-1:2015	Safety of machinery – Safety-related parts of control systems.



	Part 1: General principles for design
EN ISO 13849-2:2012	Safety of machinery – Safety-related parts of the control systems. Part 2: Validation
EN 60204-1:2018	Safety of machinery – Electrical equipment of machines – Part 1: General requirements

The following other standards have been applied:

IEC 61508:2010, parts 1-2	Functional safety of electrical / electronic / programmable electronic safety-related systems
IEC 61800-5-2:2016	Adjustable speed electrical power drive systems – Part 5-2: Safety requirements - Functional

The products referred in this Declaration of conformity fulfil the relevant provisions of other European Union Directives which are notified in Single EU Declaration of conformity 3AXD10001117584.

Authorized to compile the technical file: ABB Oy, Hiomotie 13, 00380 Helsinki, Finland

Beijing, 11 March 2022

Signed for and on behalf of:

Yu Wang 
Local Division Manager
ABB Beijing Drive Systems Co., Ltd.

XuMing Wang 
Product Engineering and Quality Manager
ABB Beijing Drive Systems Co., Ltd.



Declaration of Conformity

Supply of Machinery (Safety) Regulations 2008

We

Manufacturer: ABB Beijing Drive Systems Co., Ltd.

Address: No.1, Block D, A-10 Jiuxianqiao Beilu, Chaoyang District, Beijing 100015, P.R. China.

Phone: +86 010 58217788

declare under our sole responsibility that the following products:

Frequency converters

ACS180-04S-xxAx-1 (Frame R0, 1ph 200-240Vac)

ACS180-04S-xxAx-2 (Frame R0, 3ph 200-240Vac)

ACS180-04S-xxAx-4 (Frame R0, 3ph 380-480Vac)

ACS180-04S-xxAx-1 (Frame R1, 1ph 200-240Vac)

ACS180-04S-xxAx-2 (Frame R1, 3ph 200-240Vac)

ACS180-04S-xxAx-4 (Frame R1, 3ph 380-480Vac)

ACS180-04S-xxAx-1 (Frame R2, 1ph 200-240Vac)

ACS180-04S-xxAx-2 (Frame R2, 3ph 200-240Vac)

ACS180-04S-xxAx-4 (Frame R2, 3ph 380-480Vac)

ACS180-04S-xxAx-2 (Frame R3, 3ph 200-240Vac)

ACS180-04S-xxAx-4 (Frame R3, 3ph 380-480Vac)

ACS180-04S-xxxA-2 (Frame R4, 3ph 200-240Vac)

ACS180-04S-xxxA-4 (Frame R4, 3ph 380-480Vac)

with regard to the safety function

Safe torque-off

are in conformity with all the relevant safety component requirements of the Supply of Machinery (Safety) Regulations 2008, when the listed safety function is used for safety component functionality.

The following designated standards have been applied:

EN 61800-5-2:2007	Adjustable speed electrical power drive systems – Part 5-2: Safety requirements - Functional
EN 62061:2005 + AC:2010 + A1:2013 + A2:2015	Safety of machinery – Functional safety of safety-related electrical, electronic and programmable electronic control systems



EN ISO 13849-1:2015	Safety of machinery – Safety-related parts of control systems. Part 1: General principles for design
EN ISO 13849-2:2012	Safety of machinery – Safety-related parts of the control systems. Part 2: Validation
EN 60204-1:2018	Safety of machinery – Electrical equipment of machines – Part 1: General requirements

The following other standards have been applied:

IEC 61508:2010, parts 1-2	Functional safety of electrical / electronic / programmable electronic safety-related systems
IEC 61800-5-2:2016	Adjustable speed electrical power drive systems – Part 5-2: Safety requirements - Functional

The products referred in this declaration of conformity fulfil the relevant provisions of other UK statutory requirements, which are notified in a single declaration of conformity 3AXD10001398078.

Authorized to compile the technical file:

ABB Limited, Daresbury Park, Cheshire, United Kingdom, WA4 4BT

Beijing, 15 March 2022

Signed for and on behalf of:

 Yu Wang
 Local Division Manager
 ABB Beijing Drive Systems Co., Ltd.

 XuMing Wang
 Product Engineering and Quality Manager
 ABB Beijing Drive Systems Co., Ltd.

Further information

Product and service inquiries

Address any inquiries about the product to your local ABB representative, quoting the type designation and serial number of the unit in question. A listing of ABB sales, support and service contacts can be found by navigating to www.abb.com/searchchannels.

Product training

For information on ABB product training, navigate to new.abb.com/service/training.

Providing feedback on ABB manuals

Your comments on our manuals are welcome. Navigate to new.abb.com/drives/manuals-feedback-form.

Document library on the Internet

You can find manuals and other product documents in PDF format on the Internet at www.abb.com/drives/documents.



www.abb.com/drives



3AXD50000467945B